



Split System Cooling Units

Split System Cooling Units
7.5 to 20 Tons
Air Handlers
7.5 to 20 Tons
50 Hz





Introduction

Split System Cooling Units . . . Designed With Your Needs In Mind.



The Trane reputation for quality and reliability in air conditioning continues with the Odyssey™ family of light commercial split systems. Trane paid attention to your needs to make sure you get a system that will meet your job requirements every time...and at a competitive price.

Couple Trane's reputation for quality and reliability in split system air conditioners with efficiency, flexibility and installation ease...and you have systems that will give you "Simply the Best Value."

Manufacturing Control

Trane's exclusive control over the design and manufacturing of all major components is unique in the industry. This approach assures us total control over both the quality and reliability of these components. And allows us to custom match components to deliver the best in split system performance.

Designing the Details

Careful attention was given to designing the details — from control wiring to the access panels. Odyssey units feature time-saving colored and numbered wiring and removable panels which allow complete access to all major components and controls. All outdoor units feature external high and low pressure switches for easy diagnosing and servicing of the unit. And service valves with gauge ports are provided.

Standardized Cabinets

In addition all cabinets have been standardized; so when you are servicing an outdoor unit or an air handler all components are in the same location from unit to unit.

Filters

The TWE050, 075, and 100 air handlers are supplied with 1" (25.4 mm) throwaway filters as standard. The filter racks were designed to easily convert for installation of 2" (50.8 mm) filters. The TWE155 and 200 air handlers are supplied with 2" (50.8 mm) filters as standard.

Rated in Accordance to UL and ARI

Trane meets or exceeds all nationally recognized agency safety and design standards. Each condensing unit is designed in accordance to UL 1995 standards for central cooling air conditioners, refrigeration and air conditioning condensing and compressor units. Each air handler is designed in accordance to UL 465 and UL 1995 standard for heat pumps. Each unit is certified in accordance with ARI Standard 340/360 or 365.

Contents

Introduction	2
Features and Benefits	4
Application Considerations	8
Selection Procedure	9
Model Number Description	10
General Data	11
Performance Data	14
Cooling Performance	15
Fan Performance	42
Electrical	47
Controls	51
Dimension and Weights	58
Mechanical Specifications	76



Features and Benefits



Condensing Unit Options

The Odyssey split system product line includes condensing units in single, unloading and dual compressor options.

The TTA075A, 085A and 100A single compressor models feature single refrigeration circuitry lowering job installation costs by requiring only one set of refrigerant lines. These units are ideal for the low cost, new construction jobs as well as renovation and replacement buildings.

Equally important, Odyssey offers a single refrigerant circuit/capacity unloading option in TTA100C, 155C, and TWE200F condensing units. These unloading units feature dual manifolded scroll compressors. They offer an excellent opportunity for both new construction and replacement jobs with two stages of capacity modulation and a single refrigeration circuit.

In addition, Odyssey includes a TTA100B, 125B, 155B, and 200B dual scroll compressor unit to give true stand-by protection; if one compressor fails, the second will automatically start-up. Also, the first compressor can be serviced without shutting down the

unit since refrigerant circuits are independent.

Dual compressors are not just for protection, they also save energy costs. Most buildings are designed for the peak load requirements yet the building usually operates at less than peak load. During light load conditions only one compressor functions to maintain the space comfort thus reducing the need for energy.

Trane split systems have been specified in thousands of applications and you'll find Odyssey will win you even more jobs with its smaller, more manageable cabinet. This lighter, compact design will save time and money for rigging and installation. And the compactness will permit Trane's unit to replace almost any unit — effortlessly.

Low Ambient Cooling Operation

Each condensing unit can operate to 50°F (10°C) as standard. An accessory Head Pressure Control gives you the capability to operate to 0 F (-17.8°C). All condensing units offer these accessories:

- Head Pressure Control
- Coil Guard Kits
- Isolators both Rubber-in-Shear and Spring Type
- Anti-Short-Cycle Kit
- Time Delay Relay
- Black Epoxy Coated Coil

Air Handlers Offer More Flexibility

Flexibility is a key to meeting changing market requirements. Odyssey split systems offer not only various compressor options but also convertible air handlers. The air handlers can be installed either vertically in a mechanical room or horizontally above a ceiling. And it doesn't require any removal of panels to make either airflow application work. These air handlers have a double sloped condensate drain pan that allows for either airflow configuration. And the drain pan can easily be removed for cleaning. All the air handlers feature factory-installed belt drive and ball bearing evaporator fans with adjustable sheaves for maximum airflow performance.

Features and Benefits

Odyssey air handler versatility is further increased by a complete line of accessories designed to match and install smoothly:

- Discharge Plenum and Grille
- Return Grille
- Subbase
- Electric Heaters
- High Static Evaporator Motor
- Isolators both Rubber-in-Shear and Spring Type
- A Full Line of Thermostats
- Outdoor Thermostat



Odyssey — A Complete Split System

Odyssey delivers the flexibility to select a complete system that meets your particular job requirements. Air handlers are designed, tested, and rated with outdoor units to let you select the proper match between capacity and load. Heat pumps can also be matched with Trane built-up air handlers. Also, these matched systems can be quickly engineered for specific applications using Trane's computerized selection and load programs.

Odyssey Lowers Installation Costs

Your installation costs are reduced with Odyssey. Both outdoor units and air handlers are factory packaged and assembled so jobsite installation is quick and easy. You get a complete unit with all the components, controls and the internal wiring factory ready for a smooth jobsite start-up.

Unlike some competitive models the following components are factory-installed in Trane air handlers:

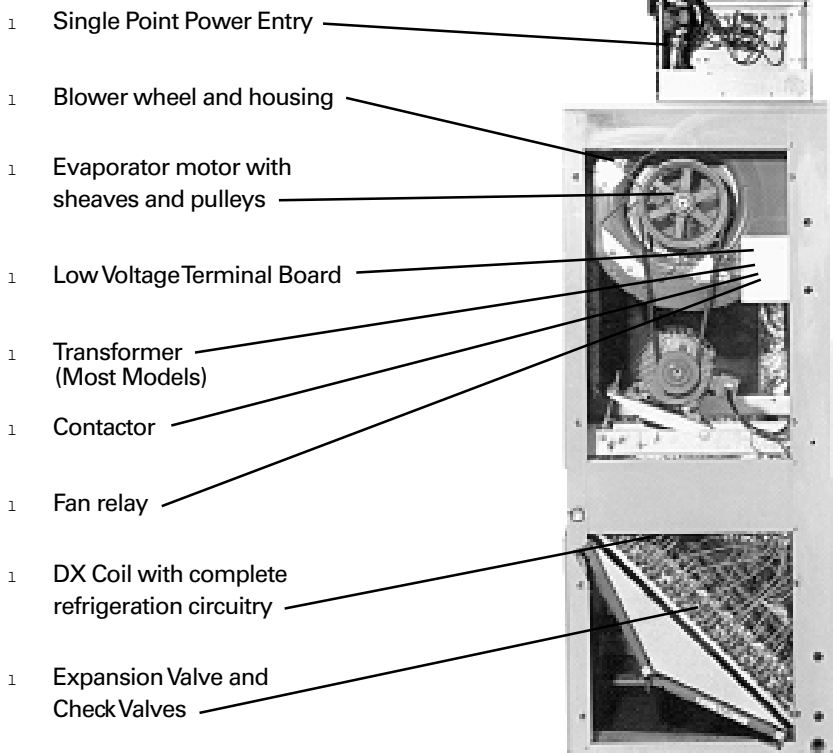

There's no need to install components and put together the air handler on the job. This provides you with less labor cost and fewer chances for installation errors which cause callbacks. All this means saving you money both in replacement and new construction applications.

Features and Benefits

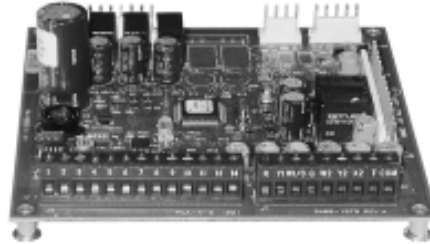

Micro Controls

Several years ago, Trane was the first to introduce microprocessor controls into the Light Commercial Market. That design, along with immeasurable experience, has provided the technology for Trane's second-generation ReliaTel™ microprocessor controls in Odyssey split unit systems — the first in the industry.

ReliaTel™ Micro:

- Provides unit control for heating and cooling, by utilizing input from sensors that measure indoor temperature.
- Improves quality and reliability through the use of time-tested microprocessor controls and logic.
- Prevents the unit from short cycling, considerably improving compressor life.
- Ensures that the compressor will run for a specific amount of time, which allows oil to return for better lubrication, enhancing the reliability of the compressor.
- Reduces the number of components required to operate the unit, thereby reducing possibilities for component failure.
- Eliminates the need for field-installed components with its built-in anti-short-cycle timer, time delay relay and minimum "on" time controls. These controls are factory tested to assure proper operation.

- Requires no special tools to run the unit through its paces during testing. Simply place a jumper between Test 1 and Test 2 terminals on the Low Voltage Terminal Board and the unit will walk through its operational steps. The unit automatically returns control to the zone sensor after stepping through the test mode a single time, even if the jumper is left on the unit.
- As long as the unit has power and the LED is lit, the Micro is operational. The light indicates that the Micro is functioning properly.
- Features expanded diagnostic capabilities when used with Trane's Integrated Comfort™ Systems.
- As an energy benefit, softens electrical "spikes" by staging on fans, compressors and heaters.
- The Intelligent Fallback or Adaptive Control is a benefit to the building occupant. If a component goes astray, the unit will continue to operate at predetermined temperature set points.
- Intelligent Anticipation is a standard feature of the Micro. Functioning constantly, the Micro and zone sensors work together in harmony, to provide tight comfort control.

Electromechanical Controls

- For the simpler job that does not require a building automation system, or expanded diagnostics capabilities, the unit offers electromechanical controls. This 24-volt control includes the control transformer, contactor pressure lugs for power wiring.

Features and Benefits

Quality And Reliability Testing

- All units were rigorously rain tested at the factory to ensure water integrity.
- Actual shipping tests were performed to determine packaging requirements. Units were test shipped around the country to determine the best packaging.
- Factory shake and drop tests were used as part of the package design process to help assure that the unit arrives at the job site in top condition.
- Rigging tests include lifting a unit into the air and letting it drop one foot, assuring that the lifting lugs and rails hold up under stress.

- We perform a 100% coil leak test at the factory. The evaporator and condenser coils are leak tested at 375 psig and pressure tested to 660 psig.
- All parts are inspected at the point of final assembly. Sub-standard parts are identified and rejected immediately.
- Every unit receives a 100% unit run test before leaving the production line to make sure it lives up to rigorous Trane requirements.

We test designs at our factory not on our customers!

VariTrac™

VariTrac

When Trane's changeover VAV System for light commercial applications is coupled with split unit systems, it provides the latest in technological advances for comfort management systems and can allow thermostat control in every zone served by VariTrac.

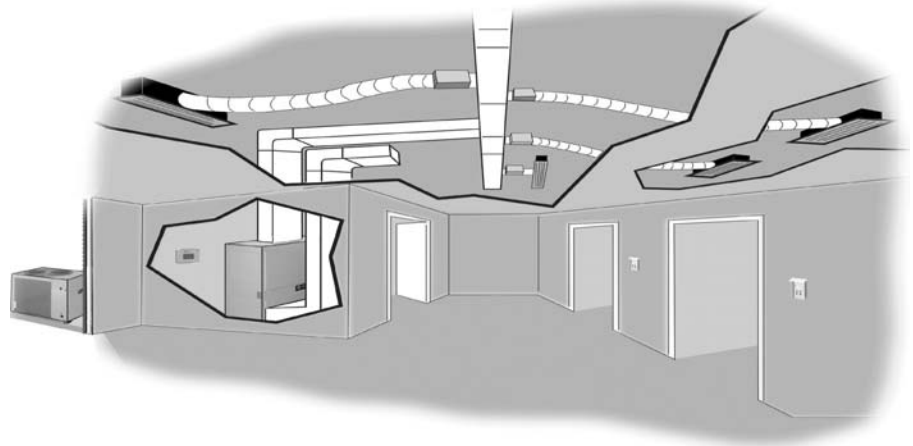



Application Considerations

Application of this product should be within the catalogued airflow and performance considerations.

Clearance Requirements

The recommended clearances identified with unit dimensions should be maintained to assure adequate serviceability, maximum capacity and peak operating efficiency. Actual clearances which appear inadequate should be reviewed with the local Trane Representative.

180° Blower Rotation

The TWE050, 075, and 100 air handler blower section can be rotated 180° to change the discharge pattern. This modification must be done in the field and requires an addition of kit. See unit installer's guide.

Low Ambient Cooling

As manufactured, these units can operate to 50° F (10°C) in the cooling mode of operation. An accessory head pressure control will allow operation to 0° F (-17.8°C) outdoor ambient. When using these units with control systems such as bypass changeover Variable Air Volume, make sure you consider the requirement for a head pressure control to allow low ambient cooling.

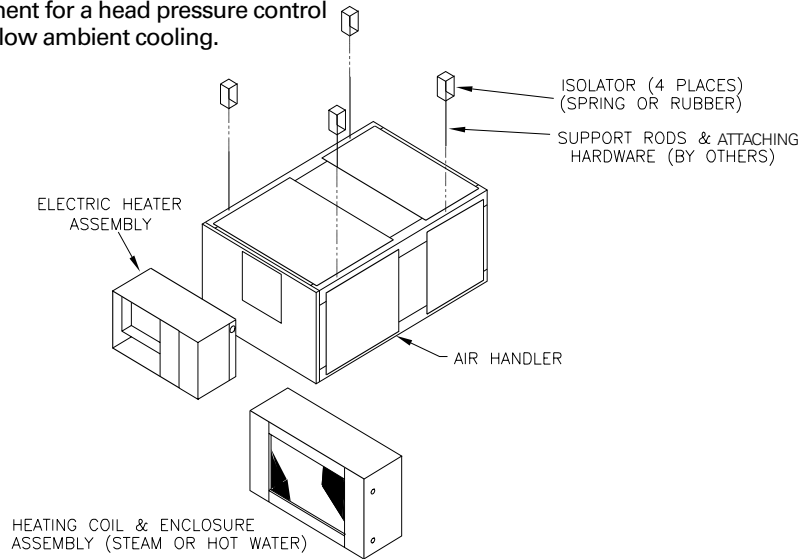

Typical Horizontal Air Handler Application

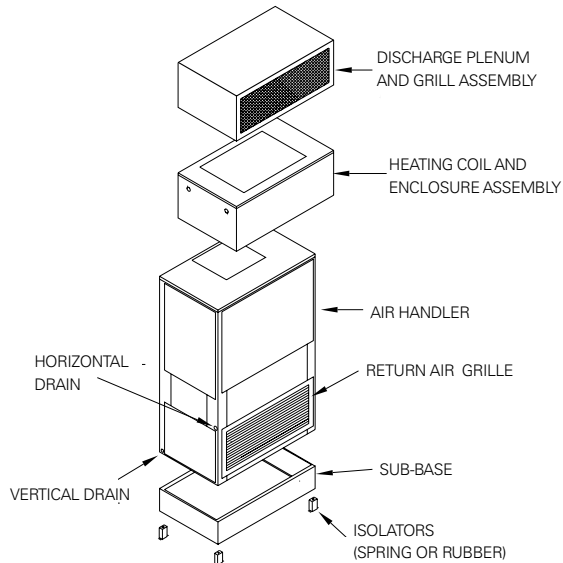

Typical Vertical Air Handler Application

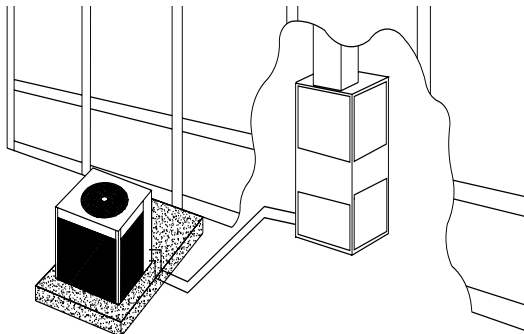

Typical Split System Application

Selection Procedure

Cooling Capacity

Step 1 — Calculate the building's total and sensible cooling loads at design conditions. Use the Trane calculation form or any other standard accepted method.

Step 2 — Size the equipment using Table PD-1. Match the cooling loads at design conditions.

Example: The following are the building cooling requirements

- a** Electrical Characteristics: 380-415/50/3
- b** Summer Design Conditions: Entering Evaporator Coil: 80 DB/67 WB (27 DB/19WB C)
Outdoor Ambient: 95° F (35° C)
- c** Total Cooling Load: 75 MBh (22 kW)
- d** Sensible Cooling Load: 53 MBh (15.5 kW)
- e** Airflow: 3000 cfm (5097 m³/h)
External Static Pressure: 0.77 in. (192.5 Pa)

Table PD-1 shows that a TTA075A matched with a TWE075A has a gross cooling capacity of 86.5 MBh (25.3 kW) and 64.4 MBh (18.8 kW) sensible capacity at 95 DB (35° C) ambient and 3000 cfm (5097 m³/h) and 80 DB/67 WB (27 DB/19WB) air entering the evaporator.

To find the net cooling capacities, fan motor heat must be subtracted. Determine the total unit static pressure:

	In.	Pa
External Static	0.77	193
Standard Filter	0.10	25
Supplementary Electric Heat	0.23	57
Total Static Pressure	1.10	275

Note: The Evaporator Fan Performance Table has included the effect of a 1 in. (250 Pa) filter already. Therefore, the actual Total Static Pressure is 1.10 - 0.10 = 1.00 in. (275 - 25 = 250 Pa).

With 3000 cfm (5097 m³/h) and 1.00 inches (250 Pa), Table PD-29 shows a 1.17 bhp (0.8 kW).

Note: The formula below the table can be used to calculate Fan Motor Heat,

$$3.5 \times \text{Bhp} = \text{MBh}$$

$$3.5 \times 1.17 = 4.10 \text{ MBh}$$

$$(1.375 \times \text{kW}) = \text{kW}$$

$$(1.375 \times 0.8 = 1.1 \text{ kW})$$

$$\text{Net Total Cooling Capacity} =$$

$$86.5 \text{ MBh} - 4.10 = 82.4 \text{ MBh}$$

$$18.8 - 1.1 = 17.7 \text{ kW}$$

$$\text{Net Sensible Cooling Capacity} =$$

$$64.4 \text{ MBh} - 4.10 = 60.3 \text{ MBh}$$

$$25.3 - 1.1 = 24.2 \text{ kW}$$

Heating Capacity

Step 1 — Calculate the building heating load.

Step 2 — Size the system heating capacity to match the calculated building heating load. The following are building heating requirements:

- a** Total Heating Load at 97.0 MBh (28.4 kW)
- b** 3000 cfm (5097 m³/h)
- c** Electric Supplementary Heaters

Table PD-39, the 34.88 kW heater has a capacity of 119,045 btu. From Table ED-5, the 34.88 kW indicates the heater model number is BAYHTRL435A. This heater will adequately cover the building's heating requirement.

Air Delivery Selection

External static pressure drop through the air distribution system has been calculated to be 0.77 inches (192.5 Pa) of water gauge. From Table PD-38 static pressure drop through the electric heater is 0.23 inches (57.5 Pa) of water (0.77 + 0.23 = 1.00 in.) (192.5 + 57.5 = 250 Pa). Enter Table 39-1 for TWE075AD at 3000 cfm (5097 m³/h) and 1.00 static pressure (250 Pa). The standard motor at 821 rpm will give the desired airflow.



Model Number Description

Split System Condensing Unit Model Nomenclature

T	T	A	1	2	0	A	4	0	0	E	A
1	2	3	4	5	6	7	8	9	10	11	12

Digits 1, 2, 3 - Product Type

TTA = Split System Cooling

Digits 4, 5, 6 - Nominal Gross Cooling Capacity (MBh)

075 = 75
 085 = 85
 100 = 100
 155 = 15.5
 200 = 200

Digit 7 - Major Development Sequence

A = 1 Refrigerant Circuit (R22)
 B = 2 Refrigerant Circuits (R22)
 C = Manifold Scroll Compressors (R22)
 D = 1 Refrigerant Circuit (R410A)
 E = 2 Refrigerant Circuits (R410A)
 F = Manifold Scroll Compressors (R410A)

Digit 8 - Electrical Characteristics

D = 380-415/50/3

Digit 9, 10 - Factory - Installed Options

00 = Packed Stock
 0S = Black Epoxy Coated Coil
 0R = ReliaTel™ Controls
 0T = ReliaTel Controls with Black Epoxy Coated Coil
 0U = ReliaTel Controls with LonTalk Communications Interface (RLCI)
 0W = ReliaTel Controls with LonTalk® Communications Interface (RLCI) and Black Epoxy Coated Coil

Digit 11- Minor Design Sequence

B = Second

Digit 12- Service Digit

A = First

Air Handler Model Nomenclature

T	W	E	0	9	0	A	1	0	0	E	A
1	2	3	4	5	6	7	8	9	10	11	12

Digits 1, 2, 3 - Product Type

TWE = Split System Heat Pump/Cooling Air Handler

Digits 4, 5, 6 - Nominal Gross Cooling Capacity (MBh)

050 = 50
 075 = 75
 100 = 100
 155 = 150
 200 = 200

Digit 7- Refrigerant Circuit

A = 1 Refrigerant Circuit (R22)
 B = 2 Refrigerant Circuits (R22)
 D = 1 Refrigerant Circuit (R410A)
 E = 2 Refrigerant Circuits (R410A)

Digit 8 - Electrical Characteristics

0 = 380-415/3/50

Digit 9, 10 - Factory - Installed Options

00 = Packed Stock

Digit 11- Minor Design Sequence

E = Current Design Sequence

Digit 12- Service Digit

A = First



General Data

Condensing Unit

Table GD-1 – General Data

	TTA075A	TTA085A	TTA100A	TTA100B
Cooling Performance¹				
Gross Cooling Capacity, btu (kW)				
Matched Air Handler (kW)	84,000(24.60)	90,000(26.35)	114,000(33.38)	112,000(32.79)
Condensing Unit Only ² (kW)	84,000(24.60)	93,000(27.23)	114,000(33.38)	112,000(32.79)
ARI Net Cooling Capacity ³ (kW)	81,000(23.72)	88,000(25.77)	110,000(32.21)	108,000(31.62)
System Power kW	7.81	7.867	10.27	10.06
Condensing Unit Power kW	7.05	7.07	9.26	9.13
Compressor				
Number	1	1	1	2
Type	Trane 3-D® Scroll	Trane 3-D® Scroll	Trane 3-D® Scroll	Trane Climatuff® Scroll
No. Motors (each)	1	1	1	1
Motor HP (kW)	6.25 (4.7)	6.91(5.15)	8.33(6.21)	4.15(3.1)
Motor RPM	2875	2875	2875	2875
ARI Sound Rating (Bels)⁴				
	8.8	8.8	8.8	8.8
System Data⁵				
No. Refrigerant Circuits	1	1	1	2
Suction Line in. (mm) OD	1.375(34.9)	1.375(34.9)	1.375(34.9)	1.125(28.58)
Liquid Line in. (mm) OD	0.500(12.7)	0.500(12.7)	0.500(12.7)	0.375(9.53)
Outdoor Coil – Type				
Tube Size in. (mm) OD	Plate Fin	Plate Fin	Plate Fin	Plate Fin
Face Area, sq. ft (m ²)	0.375(9.5)	0.375(9.5)	0.375(9.5)	0.375(9.53)
Rows	19.25(1.79)	24.0(2.23)	24.0(2.23)	24.0(2.23)
Fins Per Inch	2	2	2	2
	18	20	20	20
Outdoor Fan Type				
No. Used	Propeller	Propeller	Propeller	Propeller
Diameter in. (mm)	1	1	1	1
Drive Type	26.00(660.4)	28.00(711.2)	28.00(711.2)	28.00(711.2)
No. Speeds	Direct	Direct	Direct	Direct
CFM ⁶ (m ³ /h)	1	1	1	1
No. Motors	4700(7985.30)	8120(13795.0)	8120(13795.0)	8120(13795.0)
Motor HP (kW)	1	1	1	1
Motor RPM	0.33(.25)	0.75(.56)	0.75(.56)	0.75(.56)
	925	925	975	975
R-22 Refrigerant Charge, lb⁷ (kg)				
	16.0(7.26)	19.0(8.62)	19.0(8.62)	21.0(9.53)

Notes:

- Cooling Performance is rated at 95°F (35°C) ambient, 80°F (26.7°C) entering dry bulb, 67°F (19.4°C) entering wet bulb and nominal cfm listed. ARI rating cfm is 350 cfm/ton for this product. Gross capacity does not include the effect of fan motor heat. ARI capacity is net and includes the effect of fan motor heat. Units are suitable for operation to ±20% of nominal cfm. Certified in accordance with the Unitary Large Equipment certification program, which is based on ARI Standard 340/360 or 365-00.
- Condensing Unit Only Gross Cooling Capacity rated at 45°F (7.2°C) saturated suction temperature and at 95°F (35°C) ambient.
- ARI Net Cooling Capacity is calculated with matched blower coil and 25 ft (7.6 m) of 1.375, 0.500 OD interconnecting tubing. EER and/or SEER are rated at ARI conditions and in accordance with DOE test procedures. Integrated Part Load Value is based on ARI Standard 340/360 or 365-00. Units are rated at 80°F (26.7°C) ambient, 80°F (26.7°C) entering dry bulb, and 67°F (19.4°C) entering wet bulb at ARI rated cfm.
- Sound Rating shown is tested in accordance with ARI Standard 270.
- System Data based on maximum linear length 80 ft (26.7 m) Maximum lift: suction 60 ft (18.3 m) liquid 60 ft (18.3 m) For greater lengths, refer to refrigerant piping applications manual.
- Outdoor Fan cfm is rated with standard air-dry coil outdoor.
- Refrigerant (operating) charge is for condensing unit (all circuits) with matching blower coils and 25 ft (7.6 m) of interconnecting refrigerant lines.



General Data

Condensing Unit

Table GD-2— General Data

	TTA 100C	TTA 125B	TTA 155B	TTA 155C	TTA200B	TTA200F
Cooling Performance ¹						
Gross Cooling Capacity, btu (kW)						
Matched Air Handler	113,000(33.09)	134,000(39.24)	166,000(48.60)	167,000(48.90)	220,000(64.42)	220,000(64.42)
Condensing Unit Only ²	113,000(33.09)	130,000(38.06)	166,000(48.60)	167,000(48.90)	220,000(64.42)	220,000(64.42)
ARI Net Cooling Capacity ³	110,000(32.21)	130,000(38.06)	160,000(46.85)	161,000(47.14)	212,000(62.07)	212,000(62.07)
System Power kW	10.34	12.63	16.18	16.17	21.22	20.72
Condensing Unit Power kW	9.31	11.52	14.33	14.28	18.56	16.81
Compressor						
Number	2	2	2	2	2	2
Type	Copeland Scroll	Climatuff™ Scroll	Scroll	Scroll	Scroll	Copeland Scroll
No. Motors (each)	1	1	1	1	1	1
Motor HP (kW)	4.16(3.10)	5.20(3.9)	6.25(4.7)	6.25(4.7)	8.33(6.21)	8.29(6.18)
Motor RPM	2875	2875	2875	2875	2875	2900
ARI Sound Rating (Bels) ⁴	8.8	8.8	8.8	8.8	8.8	9.2
System Data ⁵						
No. Refrigerant Circuits	1	2	2	1	2	1
Suction Line in. (mm) OD	1.375(34.9)	1.125(28.58)	1.375(34.9)	1.625(41.3)	1.375(34.9)	1.625(41.3)
Liquid Line in. (mm) OD	0.500(12.7)	0.375(9.53)	0.500(12.7)	0.625(15.9)	0.500(12.7)	0.625(15.9)
Outdoor Coil — Type						
Tube Size in. (mm) OD	0.375(9.5)	0.375(9.5)	0.375(9.5)	0.375(9.5)	0.375(9.5)	0.375(9.5)
Face Area, sq. ft (m ²)	24.0(2.23)	24.0(2.23)	33.33(3.10)	33.33(3.10)	50.2(4.66)	52.9(4.91)
Rows	2	2	2	2	2	2
Fins Per Inch	20	20	20	20	18	18
Outdoor Fan Type						
Propeller	Propeller	Propeller	Propeller	Propeller	Propeller	Propeller
No. Used	1	1	2	2	2	2
Diameter in. (mm)	28.00(711.2)	28.00(711.2)	26.00(660.4)	26.00(660.4)	28.00(711.2)	28.00(711.2)
Drive Type	Direct	Direct	Direct	Direct	Direct	Direct
No. Speeds	1	1	1	1	1	1
CFM 6 (m ³ /h)	8120(13795.0)	8120(13795.0)	9400(15970.60)	9400(15970.60)	13400(22766.60)	12100(20558)
No. Motors	1	1	1	1	2	2
Motor HP (kW)	0.75(.56)	0.75(.56)	0.33(.25)	0.33(.25)	0.75(.56)	0.75(.56)
Motor RPM	925	925	925	925	925	925
R-22 Refrigerant Charge, lb⁷ (kg)	20.5(9.30)	23.6(10.70)	30.0(13.61)	28.0(12.70)	39.5(17.92)	413(18.7)-R410A

1. Cooling Performance is rated at 95°F (35°C) ambient, 80°F (26.7°C) entering dry bulb, 67°F (19.4°C) entering wet bulb and nominal cfm listed. ARI rating cfm is 350 cfm/ton for this product. Gross capacity does not include the effect of fan motor heat. ARI capacity is net and includes the effect of fan motor heat. Units are suitable for operation to ±20% of nominal cfm. Certified in accordance with the Unitary Large Equipment certification program, which is based on ARI Standard 340/360 or 365-00.

2. Condensing Unit Only Gross Cooling Capacity rated at 45°F (7.2°C) saturated suction temperature and at 95°F (35°C) ambient.

3. ARI Net Cooling Capacity is calculated with matched blower coil and 25 ft (7.2 m) of 1.375, 0.500 OD interconnecting tubing (1 5/8" suction and 5/8" liquid for TTA200F). EER and/or SEER are rated at ARI conditions and in accordance with DOE test procedures. Integrated Part Load Value is based on ARI Standard 340/360 or 365-00. Units are rated at 80°F (26.7°C) ambient, 80°F (26.7°C) entering dry bulb, and 67°F (19.4°C) entering wet bulb at ARI rated cfm.

4. Sound Rating shown is tested in accordance with ARI Standard 270.

5. System Data based on maximum linear length 80 ft (26.7 m) Maximum lift: suction 60 ft (18.3 m) liquid 60 ft (18.3 m) For greater lengths, refer to refrigerant piping applications manual.

6. Outdoor Fan cfm is rated with standard air-dry coil outdoor.

7. Refrigerant (operating) charge is for condensing unit (all circuits) with matching blower coils and 25 ft (7.6 m) of interconnecting refrigerant lines.



General Data

Air Handler

Table GD-3 – General Data

	TWE050A	TWE075A	TWE100A	TWE100B
System Data¹				
No. Refrigerant Circuits	1	1	1	2
Suction Line in. (mm) OD	1.120(28.4)	1.380(35.0)	1.380(35.0)	1.380(35.0)
Liquid Line in. (mm) OD	0.38(9.7)	0.50(12.7)	0.50(12.7)	0.50(12.7)
Indoor Coil – Type				
Tube Size in. (mm) OD	Plate Fin 0.375(9.5)	Plate Fin 0.375(9.5)	Plate Fin 0.375(9.5)	Plate Fin 0.375(9.5)
Face Area sq. ft (m ²)	5.00(.47)	8.07(.75)	11.18(1.0)	11.18(1.0)
Rows	3	3	4	4
Fins Per Inch	12	12	12	12
Refrigerant Control	Expansion Valve	Expansion Valve	Expansion Valve	Expansion Valve
Drain Connection No.	4	4	4	4
Drain Connection Size in. (mm)	0.75(19.0)	0.75(19.0)	0.75(19.0)	0.75(19.0)
Drain Connection Type	PVC	PVC	PVC	PVC
Indoor Fan Type				
No. Used	FC Centrifugal 1	FC Centrifugal 1	FC Centrifugal 1	FC Centrifugal 1
Diameter in. (mm)	12.0(304.8)	15.0(381)	15.0(381)	15.0(381)
Width in. (mm)	12.0(304.8)	15.0(381)	15.0(381)	15.0(381)
Drive Type	Belt	Belt	Belt	Belt
No. Speeds	1	1	1	1
CFM (m ³ /h)	1670(2837)	2500(4247)	3325(5649)	3325(5649)
No. Motors	1	1	1	1
Motor HP (kW)				
- Standard/Oversized	0.75/1.0(.55/.74)	1.0/1.5(.74/1.11)	1.5/2.0(1.11/1.49)	1.5/2.0(1.11/1.49)
Motor RPM (Standard)	1425	1425	1425	1425
Motor Frame Size (Standard)	56	56	56	56
Filters – Type				
Furnished	Throwaway	Throwaway	Throwaway	Throwaway
No.	Yes 1/1	Yes 3	Yes 4	Yes 4
Recommended Size, in. (mm)	16x20x1/20x20x1 (406.4x508x25.4/ 508x508x25.4)	16x25x1 (406.4x635x25.4)	16x25x1 (406.4x635x25.4)	16x25x1 (406.4x635x25.4)

Notes:

1. ARI certified with various condensing units per ARI Standard 210/240 or 340/360 or 365-00. Refer to Performance Data section in this catalog.

Table GD-4 – General Data

	TWE155B	TWE200B,E
System Data		
No. Refrigerant Circuits	2	2
Suction Line in. (mm) OD	1.38(35.0)	1.38(35.0)
Liquid Line in. (mm) OD	0.500(12.7)	0.500(12.7)
Indoor Coil – Type		
Tube Size in. (mm) OD	Plate Fin 0.375(9.5)	Plate Fin 0.375(9.5)
Face Area sq. ft (m ²)	16.33(1.52)	21.63(2.01)
Rows	3	3
Fins Per Inch	12	12
Refrigerant Control	Expansion Valve	Expansion Valve
Drain Connection No.	4	4
Drain Connection Size in. (mm)	1.000(25.4)	1.000(25.4)
Drain Connection Type	PVC	PVC
Indoor Fan Type		
No. Used	FC Centrifugal 2	FC Centrifugal 2
Diameter in. (mm)	15.0(381)	15.0(381)
Width in. (mm)	15.0(381)	15.0(381)
Drive Type	Belt	Belt
No. Speeds	1	1
CFM (m ³ /h)	5000(8494)	6650(11297)
No. Motors	1	1
Motor HP – Standard/Oversized	2.0/3.0(1.49/2.24)	3.0/5.0(2.24/3.72)
Motor RPM (Standard)	1425	1425
Motor Frame Size (Standard)	145T	184T
Filters – Type		
Furnished	Throwaway	Throwaway
No.	Yes 8	Yes 4/4
Recommended Size, in. (mm)	15x20x2 (381x508x50.8)	16x20x2/16x25x2 (406.4x508x50.8/ 406.4x635x50.8)

Notes:

1. ARI certified with various condensing units per ARI Standard 210/240 or 340/360 or 365-00. Refer to Performance Data section in this catalog.



Performance Data System

Table PD-1 — Gross Cooling Capacities (MBh) TTA075A Condensing Unit with TWE075A Air Handler (I-P)

CFM		Ambient Temperature (°F)																							
		85						95						105						115					
		Enter. Dry Bulb		Entering Wet Bulb (°F)																					
Airflow	(°F)	TGC	SHC	TGC	SHC	TGC	SHC	TGC	SHC	TGC	SHC	TGC	SHC	TGC	SHC	TGC	SHC	TGC	SHC	TGC	SHC	TGC	SHC	TGC	SHC
2250	75	77.2	60.6	85.4	50.9	94.1	34.7	74.8	59.4	82.6	49.8	90.9	33.6	71.8	57.9	79.3	48.4	87.2	32.3	68.4	56.2	75.5	46.9	83.0	30.8
	80	77.6	70.5	85.6	58.4	94.2	45.3	75.2	69.3	82.8	57.2	91.0	44.1	72.3	67.9	79.5	55.8	87.3	42.7	69.0	66.2	75.6	54.0	83.2	41.2
	85	79.1	79.1	85.7	68.3	94.3	55.6	77.0	77.0	83.0	67.0	91.2	54.4	74.6	74.6	79.6	65.6	87.5	53.0	71.7	71.7	75.9	63.9	83.4	51.5
2500	75	78.8	63.4	87.0	49.9	95.7	35.4	76.2	62.1	84.1	48.7	92.4	34.2	73.2	60.6	80.7	47.2	88.5	32.9	69.6	58.9	76.7	45.6	84.2	31.4
	80	79.3	74.3	87.2	61.1	95.8	46.8	76.8	73.1	84.2	59.7	92.5	45.6	73.9	71.6	80.8	58.2	88.7	44.2	70.5	70.0	76.9	56.4	84.4	42.6
	85	81.7	81.7	87.4	71.8	96.0	58.1	79.6	79.6	84.5	70.5	92.7	56.8	77.0	77.0	81.0	69.0	88.9	55.4	73.9	73.9	77.2	67.3	84.6	53.9
2750	75	80.1	66.1	88.3	51.5	97.0	36.0	77.5	64.8	85.3	50.3	93.5	34.8	74.3	63.2	81.8	48.8	89.6	33.4	70.7	61.5	77.7	47.2	85.2	31.8
	80	80.9	78.0	88.4	63.4	97.1	48.2	78.3	76.7	85.5	62.1	93.7	47.0	75.3	75.2	81.9	60.5	89.8	45.6	71.9	71.9	77.9	58.8	85.4	44.0
	85	84.1	84.1	88.7	75.1	97.3	60.4	81.8	81.8	85.7	73.8	93.9	59.1	79.0	79.0	82.3	72.2	90.0	57.7	75.8	75.8	78.3	70.5	85.5	55.9
3000	75	81.3	68.6	89.5	53.1	98.0	36.5	78.5	67.3	86.4	51.9	94.5	35.2	75.3	65.7	82.7	50.4	90.5	33.8	71.6	63.9	78.6	48.7	85.9	32.2
	80	82.3	81.5	89.6	65.7	98.2	49.6	79.4	79.4	86.5	64.4	94.7	48.3	76.6	76.6	82.9	62.8	90.7	46.9	73.5	73.5	78.8	61.1	86.3	45.3
	85	86.1	86.1	89.9	78.3	98.4	62.6	83.7	83.7	86.9	76.9	94.9	61.3	80.8	80.8	83.4	75.4	90.8	59.6	77.5	77.5	79.4	73.7	86.4	57.9
90	90.5	90.5	90.6	90.6	98.5	75.0	88.0	88.0	88.1	88.1	95.0	73.6	85.0	85.0	85.1	85.1	91.1	72.1	81.6	81.6	81.7	81.7	86.7	70.4	

Equal TGC and SHC values constitute dry coil conditions. Total Gross Cooling (TGC) shown to the left is not applicable. In this case the Sensible Heat Capacity (SHC) is the total capacity.

All capacities shown are gross and have not considered indoor fan heat.
 To obtain net cooling capacities subtract indoor fan heat.
 TGC = Total Gross Cooling Capacity
 SHC = Sensible Heat Capacity

Table PD-1 — Gross Cooling Capacities (kW) TTA075A Condensing Unit with TWE075A Air Handler (SI)

m³/h		Ambient Temperature (°C)																							
		29.4				35.0				40.6				46.1											
		Enter. Dry Bulb		Entering Wet Bulb (°C)																					
Airflow	(°C)	TGC	SHC	TGC	SHC	TGC	SHC	TGC	SHC	TGC	SHC	TGC	SHC	TGC	SHC	TGC	SHC	TGC	SHC	TGC	SHC				
3823	24	22.6	17.7	25.0	14.9	27.6	10.2	21.9	17.4	24.2	14.6	26.6	9.8	21.0	16.9	23.2	14.2	25.5	9.5	20.0	16.5	22.1	13.7	24.3	9.0
	27	22.7	20.7	25.1	17.1	27.6	13.3	22.0	20.3	24.3	16.8	26.6	12.9	21.2	19.9	23.3	16.3	25.6	12.5	20.2	19.4	22.1	15.8	24.3	12.1
	29	23.2	23.2	25.1	20.0	27.6	16.3	22.6	22.6	24.3	19.6	26.7	15.9	21.8	21.8	23.3	19.2	25.6	15.5	21.0	21.0	22.2	18.7	24.4	15.1
	32	24.3	24.3	25.2	22.9	27.7	19.3	23.7	23.7	24.4	22.6	26.7	18.9	23.0	23.0	23.5	22.1	25.6	18.5	22.1	22.1	22.4	21.7	24.4	18.0
4248	24	23.1	18.6	25.5	14.6	28.0	10.4	22.3	18.2	24.6	14.3	27.0	10.0	21.4	17.7	23.6	13.8	25.9	9.6	20.4	17.2	22.5	13.4	24.7	9.2
	27	23.2	21.8	25.5	17.9	28.0	13.7	22.5	21.4	24.7	17.5	27.1	13.3	21.6	21.0	23.7	17.0	26.0	12.9	20.7	20.5	22.5	16.5	24.7	12.5
	29	23.9	23.9	25.6	21.0	28.1	17.0	23.3	23.3	24.7	20.6	27.1	16.6	22.5	22.5	23.7	20.2	26.0	16.2	21.6	21.6	22.6	19.7	24.8	15.8
	32	25.2	25.2	25.8	24.2	28.1	20.2	24.5	24.5	24.9	23.9	27.2	19.8	23.7	23.7	24.0	23.4	26.1	19.4	22.8	22.8	22.8	22.8	24.8	18.9
4672	24	23.5	19.3	25.9	15.1	28.4	10.5	22.7	19.0	25.0	14.7	27.4	10.2	21.8	18.5	23.9	14.3	26.2	9.8	20.7	18.0	22.8	13.8	24.9	9.3
	27	23.7	22.8	25.9	18.6	28.4	14.1	22.9	22.5	25.0	18.2	27.4	13.8	22.1	22.0	24.0	17.7	26.3	13.3	21.0	21.0	22.8	17.2	25.0	12.9
	29	24.6	24.6	26.0	22.0	28.5	17.7	24.0	24.0	25.1	21.6	27.5	17.3	23.1	23.1	24.1	21.2	26.3	16.9	22.2	22.2	22.9	20.7	25.0	16.4
	32	25.9	25.9	26.2	25.5	28.5	21.1	25.2	25.2	25.4	25.1	27.5	20.7	24.3	24.3	24.4	24.4	26.4	20.3	23.4	23.4	23.4	23.4	25.1	19.8
5097	24	23.8	20.1	26.2	15.5	28.7	10.7	23.0	19.7	25.3	15.2	27.7	10.3	22.0	19.2	24.2	14.8	26.5	9.9	21.0	18.7	23.0	14.3	25.2	9.4
	27	24.1	23.9	26.2	19.2	28.8	14.5	23.2	23.2	25.3	18.8	27.7	14.1	22.4	22.4	24.3	18.4	26.6	13.7	21.5	21.5	23.1	17.9	25.3	13.3
	29	25.2	25.2	26.3	22.9	28.8	18.3	24.5	24.5	25.4	22.5	27.8	18.0	23.7	23.7	24.4	22.1	26.6	17.5	22.7	22.7	23.2	21.6	25.3	17.0
	32	26.5	26.5	26.5	26.5	28.8	22.0	25.8	25.8	25.8	25.8	27.8	21.6	24.9	24.9	24.9	24.9	26.7	21.1	23.9	23.9	23.9	23.9	25.4	20.6

Equal TGC and SHC values constitute dry coil conditions. Total Gross Cooling (TGC) shown to the left is not applicable. In this case the Sensible Heat Capacity (SHC) is the total capacity.

All capacities shown are gross and have not considered indoor fan heat.
 To obtain net cooling capacities subtract indoor fan heat.
 TGC = Total Gross Cooling Capacity
 SHC = Sensible Heat Capacity



Performance Data

System

Table PD-2 — Gross Cooling Capacities (MBh) TTA075A Condensing Unit with TWE100A Air Handler

(I-P)

CFM		Ambient Temperature (°F)																																																																																																				
		85						95						105						115																																																																																		
		Enter. Dry Bulb (°F)		Entering Wet Bulb (°F)																																																																																																		
Airflow		61	67	73	61	67	73	61	67	73	61	67	73	61	67	73	61	67	73	61	67	73	61	67	73																																																																													
2550	75	82.1	66.3	90.5	55.2	99.3	36.7	79.5	65.0	87.6	54.0	95.9	35.6	76.2	63.4	84.0	52.6	92.0	34.3	72.3	61.5	80.0	51.0	87.6	32.8	80	82.6	77.8	90.7	63.7	99.4	48.7	80.0	76.5	87.8	62.5	96.1	47.5	76.9	75.0	84.1	60.8	92.2	46.1	73.3	73.2	80.1	59.1	87.9	44.5	85	85.2	85.2	90.8	75.0	99.6	60.5	83.0	83.0	87.9	73.7	96.3	59.2	80.2	80.2	84.4	72.2	92.5	57.8	77.1	77.1	80.4	70.5	88.1	56.3	90	89.5	89.5	91.3	86.6	99.7	72.2	87.1	87.1	88.5	85.3	96.3	70.7	84.3	84.3	85.1	83.8	92.5	69.2	81.1	81.1	81.2	81.2	88.2	67.6		
	2850	75	83.7	69.7	92.2	54.1	100.8	37.5	81.0	68.4	89.1	52.8	97.4	36.2	77.6	66.7	85.4	51.3	93.3	34.8	73.7	64.9	81.3	49.7	88.8	33.2	80	84.5	82.4	92.2	66.7	101.0	50.5	81.9	81.2	89.2	65.4	97.6	49.2	78.6	78.6	85.5	63.8	93.6	47.8	75.3	75.3	81.4	62.1	89.2	46.2	85	88.1	88.1	92.4	79.2	101.2	63.4	85.7	85.7	89.4	77.9	97.7	62.1	82.8	82.8	85.8	76.4	93.8	60.7	79.5	79.5	81.8	74.6	89.4	59.2	90	92.5	92.5	93.3	92.0	101.2	75.9	90.1	90.1	90.1	90.1	97.8	74.6	87.1	87.1	87.2	87.2	93.9	73.1	83.7	83.7	83.8	83.8	89.5	71.4	
		3150	75	85.1	72.9	93.5	56.0	102.0	38.0	82.2	71.6	90.3	54.8	98.5	36.8	78.8	69.9	86.6	53.3	94.4	35.4	74.8	68.0	82.3	51.6	89.8	33.8	80	86.0	86.0	93.6	69.7	102.3	52.1	83.6	83.6	90.4	68.3	98.7	50.9	80.6	80.6	86.7	66.7	94.7	49.5	77.3	77.3	82.5	64.9	90.2	47.9	85	90.5	90.5	93.8	83.3	102.5	66.2	88.0	88.0	90.8	82.0	98.9	64.9	85.0	85.0	87.1	80.4	94.8	63.2	81.6	81.6	83.0	78.6	90.4	61.5	90	95.1	95.1	95.2	95.2	102.5	79.6	92.5	92.5	92.6	92.6	99.0	78.3	89.4	89.4	89.5	89.5	95.1	76.8	85.9	85.9	86.0	86.0	90.6	75.1
			3450	75	86.2	76.0	94.6	57.9	103.1	38.6	83.3	74.6	91.3	56.6	99.4	37.3	79.9	73.0	87.5	55.1	95.3	35.9	75.9	71.1	83.0	53.1	90.6	34.3	80	88.0	88.0	94.7	72.5	103.3	53.7	85.5	85.5	91.5	71.1	99.7	52.5	82.5	82.5	87.7	69.5	95.7	51.1	79.0	79.0	83.4	67.7	91.1	49.5	85	92.7	92.7	95.1	87.2	103.4	68.6	90.1	90.1	92.0	85.9	99.8	67.2	86.9	86.9	88.3	84.3	95.8	65.7	83.4	83.4	84.2	82.5	91.3	64.0	90	97.4	97.4	97.4	97.4	103.6	83.2	94.6	94.6	94.7	94.7	100.0	81.9	91.4	91.4	91.5	91.5	96.0	80.4	87.8	87.8	87.9	87.9	91.5

Equal TGC and SHC values constitute dry coil conditions. Total Gross Cooling (TGC) shown to the left is not applicable. In this case the Sensible Heat Capacity (SHC) is the total capacity.

All capacities shown are gross and have not considered indoor fan heat.
 To obtain net cooling capacities subtract indoor fan heat.
 TGC = Total Gross Cooling Capacity
 SHC = Sensible Heat Capacity

Table PD-2 — Gross Cooling Capacities (kW) TTA075A Condensing Unit with TWE100A Air Handler

(SI)

m³/h		Ambient Temperature (°C)																																																																																																				
		29.4				35.0				40.6				46.1																																																																																								
		Enter. Dry Bulb (°C)		Entering Wet Bulb (°C)																																																																																																		
Airflow		16.1	19.4	22.8	16.1	19.4	22.8	16.1	19.4	22.8	16.1	19.4	22.8	16.1	19.4	22.8																																																																																						
4332	23.9	24.0	19.4	26.5	16.2	29.1	10.8	23.3	19.0	25.6	15.8	28.1	10.4	22.3	18.6	24.6	15.4	26.9	10.0	21.2	18.0	23.4	14.9	25.7	9.6	29.4	25.0	25.0	26.6	22.0	29.1	17.7	24.3	24.3	25.7	21.6	28.2	17.3	23.5	23.5	24.7	21.1	27.1	16.9	22.6	22.6	23.5	20.6	25.8	16.5	32.2	26.2	26.2	26.7	25.3	29.2	21.1	25.5	25.5	25.9	25.0	28.2	20.7	24.7	24.7	24.9	24.5	27.1	20.3	23.7	23.7	23.8	23.8	25.8	19.8																											
	4842	23.9	24.5	20.4	27.0	15.8	29.5	11.0	23.7	20.0	26.1	15.5	28.5	10.6	22.7	19.5	25.0	15.0	27.3	10.2	21.6	19.0	23.8	14.5	26.0	9.7	26.7	24.7	24.1	27.0	19.5	29.6	14.8	24.0	23.8	26.1	19.2	28.6	14.4	23.0	23.0	25.0	18.7	27.4	14.0	22.0	22.0	23.8	18.2	26.1	13.5	29.4	25.8	25.8	27.1	23.2	29.6	18.6	25.1	25.1	26.2	22.8	28.6	18.2	24.3	24.3	25.1	22.4	27.5	17.8	23.3	23.3	23.9	21.8	26.2	17.3	32.2	27.1	27.1	27.3	26.9	29.6	22.2	26.4	26.4	26.4	26.4	28.6	21.8	25.5	25.5	25.5	25.5	27.5	21.4	24.5	24.5	24.5	24.5	26.2	20.9	
		5352	23.9	24.9	21.4	27.4	16.4	29.9	11.1	24.1	21.0	26.4	16.0	28.8	10.8	23.1	20.5	25.3	15.6	27.6	10.4	21.9	19.9	24.1	15.1	26.3	9.9	26.7	25.2	25.2	27.4	20.4	29.9	15.3	24.5	24.5	26.5	20.0	28.9	14.9	23.6	23.6	25.4	19.5	27.7	14.5	22.6	22.6	24.2	19.0	26.4	14.0	29.4	26.5	26.5	27.5	24.4	30.0	19.4	25.8	25.8	26.6	24.0	29.0	19.0	24.9	24.9	25.5	23.5	27.8	18.5	23.9	23.9	24.3	23.0	26.5	18.0	32.2	27.8	27.8	27.9	27.9	30.0	23.3	27.1	27.1	27.1	27.1	29.0	22.9	26.2	26.2	26.2	26.2	27.8	22.5	25.1	25.1	25.2	25.2	26.5	22.0
			5862	23.9	25.2	22.3	27.7	17.0	30.2	11.3	24.4	21.9	26.7	16.6	29.1	10.9	23.4	21.4	25.6	16.1	27.9	10.5	22.2	20.8	24.3	15.6	26.5	10.0	26.7	25.8	25.8	27.7	21.2	30.3	15.7	25.0	25.0	26.8	20.8	29.2	15.4	24.2	24.2	25.7	20.3	28.0	15.0	23.1	23.1	24.4	19.8	26.7	14.5	29.4	27.1	27.1	27.8	25.5	30.3	20.1	26.4	26.4	26.9	25.1	29.2	19.7	25.5	25.5	25.8	24.7	28.1	19.2	24.4	24.4	24.6	24.2	26.7	18.7	32.2	28.5	28.5	28.5	28.5	30.3	24.4	27.7	27.7	27.7	27.7	29.3	24.0	26.8	26.8	26.8	26.8	28.1	23.5	25.7	25.7	25.7	25.7	26.8

Equal TGC and SHC values constitute dry coil conditions. Total Gross Cooling (TGC) shown to the left is not applicable. In this case the Sensible Heat Capacity (SHC) is the total capacity.

All capacities shown are gross and have not considered indoor fan heat.
 To obtain net cooling capacities subtract indoor fan heat.
 TGC = Total Gross Cooling Capacity
 SHC = Sensible Heat Capacity



Performance Data System

Table PD-3 — Gross Cooling Capacities (MBh) TTA085A Condensing Unit with TWE075A Air Handler (I-P)

		Ambient Temperature (°F)																							
		85						95						105						115					
		Enter. Dry Bulb		Entering Wet Bulb (°F)																					
CFM	(°F)	61	67	73	81	87	93	61	67	73	81	87	93	61	67	73	81	87	93	61	67	73	81	87	93
Airflow	(°F)	TGC	SHC	TGC	SHC	TGC	SHC	TGC	SHC	TGC	SHC	TGC	SHC	TGC	SHC	TGC	SHC	TGC	SHC	TGC	SHC	TGC	SHC	TGC	SHC
2250	75	82.5	63.0	91.6	53.2	101.7	37.2	79.6	61.5	88.4	51.9	98.1	35.9	76.5	60.0	85.0	50.5	94.3	34.6	73.3	58.3	81.5	49.1	90.4	33.2
	80	82.8	72.9	91.9	61.0	101.7	48.1	80.0	71.4	88.7	59.6	98.2	46.7	77.0	69.9	85.4	58.1	94.5	45.3	73.8	68.3	81.9	56.6	90.6	43.8
	85	84.0	83.3	92.1	70.9	102.0	58.4	81.0	81.0	88.9	69.4	98.4	57.0	78.5	78.5	85.5	67.9	94.8	55.6	75.9	75.9	82.1	66.3	90.9	54.1
	90	87.7	87.7	92.4	80.8	102.2	68.7	85.3	85.3	89.3	79.4	98.7	67.3	82.7	82.7	86.0	77.9	95.0	65.9	80.1	80.1	82.6	76.3	91.0	64.1
2500	75	84.4	65.9	93.6	52.5	103.7	37.9	81.4	64.4	90.3	51.1	99.9	36.6	78.2	62.8	86.8	49.6	96.0	35.3	74.8	61.1	83.1	48.1	91.9	33.9
	80	84.8	76.7	93.9	63.8	103.7	49.6	81.9	75.2	90.6	62.3	100.0	48.2	78.8	73.7	86.9	60.6	96.2	46.8	75.6	72.1	83.3	59.0	92.2	45.3
	85	86.4	86.4	94.1	74.4	104.0	60.9	83.9	83.9	90.8	72.9	100.4	59.5	81.3	81.3	87.3	71.4	96.5	58.1	78.6	78.6	83.7	69.8	92.6	56.6
	90	90.9	90.9	94.5	85.3	104.3	72.1	88.4	88.4	91.3	83.9	100.4	70.4	85.7	85.7	88.0	82.4	96.7	68.9	82.9	82.9	84.5	80.8	92.7	67.3
2750	75	85.9	68.6	95.2	54.2	105.2	38.7	82.8	67.0	91.8	52.8	101.4	37.3	79.5	65.4	88.2	51.3	97.3	36.0	76.1	63.7	84.4	49.8	93.1	34.5
	80	86.5	80.4	95.3	66.1	105.4	51.1	83.5	78.9	91.9	64.6	101.6	49.7	80.4	77.3	88.4	63.0	97.6	48.2	77.1	75.7	84.7	61.4	93.5	46.8
	85	89.0	89.0	95.7	77.8	105.7	63.3	86.4	86.4	92.3	76.3	101.9	61.9	83.7	83.7	88.8	74.7	98.0	60.4	80.9	80.9	85.1	73.1	93.9	59.0
	90	93.8	93.8	96.4	89.7	105.8	75.0	91.1	91.1	93.2	88.2	102.1	73.5	88.3	88.3	89.8	86.7	98.2	72.0	85.4	85.4	86.3	85.1	94.2	70.4
3000	75	87.3	71.2	96.6	55.9	106.6	39.4	84.1	69.6	93.1	54.4	102.6	38.0	80.7	68.0	89.4	52.9	98.5	36.5	77.2	66.2	85.5	51.3	94.2	35.0
	80	88.1	83.9	96.8	68.5	106.8	52.5	85.1	82.4	93.3	67.0	102.9	51.1	81.9	80.8	89.6	65.3	98.9	49.6	78.3	78.3	85.8	63.7	94.7	48.1
	85	91.4	91.4	97.2	81.0	107.2	65.6	88.7	88.7	93.7	79.5	103.3	64.2	85.9	85.9	90.1	77.9	99.3	62.7	82.9	82.9	86.3	76.3	94.9	60.8
	90	96.3	96.3	98.2	93.9	107.3	78.0	93.5	93.5	94.9	92.4	103.5	76.5	90.6	90.6	91.4	90.8	99.5	74.9	87.6	87.6	87.6	87.6	95.4	73.3

Equal TGC and SHC values constitute dry coil conditions. Total Gross Cooling (TGC) shown to the left is not applicable. In this case the Sensible Heat Capacity (SHC) is the total capacity.

All capacities shown are gross and have not considered indoor fan heat.
 To obtain net cooling capacities subtract indoor fan heat.
 TGC = Total Gross Cooling Capacity
 SHC = Sensible Heat Capacity

Table PD-3 — Gross Cooling Capacities (kW) TTA085A Condensing Unit with TWE075A Air Handler (SI)

		Ambient Temperature (°C)																							
		29.4				35.0				40.6				46.1											
		Enter. Dry Bulb		Entering Wet Bulb (°C)																					
m³/h	(°C)	16.1	19.4	22.8	16.1	19.4	22.8	16.1	19.4	22.8	16.1	19.4	22.8												
Airflow	(°C)	TGC	SHC	TGC	SHC	TGC	SHC	TGC	SHC	TGC	SHC	TGC	SHC	TGC	SHC										
3823	24	24.2	18.5	26.8	15.6	29.8	10.9	23.3	18.0	25.9	15.2	28.7	10.5	22.4	17.6	24.9	14.8	27.6	10.1	21.5	17.1	23.9	14.4	26.5	9.7
	27	24.2	21.3	26.9	17.9	29.8	14.1	23.4	20.9	26.0	17.4	28.7	13.7	22.5	20.5	25.0	17.0	27.7	13.3	21.6	20.0	24.0	16.6	26.5	12.8
	29	24.6	24.4	27.0	20.8	29.9	17.1	23.7	23.7	26.0	20.3	28.8	16.7	23.0	23.0	25.0	19.9	27.7	16.3	22.2	22.2	24.0	19.4	26.6	15.9
	32	25.7	25.7	27.0	23.7	29.9	20.1	25.0	25.0	26.1	23.2	28.9	19.7	24.2	24.2	25.2	22.8	27.8	19.3	23.4	23.4	24.2	22.3	26.7	18.8
4248	24	24.7	19.3	27.4	15.4	30.3	11.1	23.8	18.8	26.4	15.0	29.3	10.7	22.9	18.4	25.4	14.5	28.1	10.3	21.9	17.9	24.3	14.1	26.9	9.9
	27	24.8	22.5	27.5	18.7	30.4	14.5	24.0	22.0	26.5	18.3	29.3	14.1	23.1	21.6	25.4	17.7	28.2	13.7	22.1	21.1	24.4	17.3	27.0	13.3
	29	25.3	25.3	27.5	21.8	30.5	17.8	24.6	24.6	26.6	21.4	29.4	17.4	23.8	23.8	25.6	20.9	28.3	17.0	23.0	23.0	24.5	20.4	27.1	16.6
	32	26.6	26.6	27.7	25.0	30.5	21.1	25.9	25.9	26.7	24.6	29.4	20.6	25.1	25.1	25.8	24.1	28.3	20.2	24.3	24.3	24.8	23.7	27.2	19.7
4672	24	25.2	20.1	27.9	15.9	30.8	11.3	24.3	19.6	26.9	15.5	29.7	10.9	23.3	19.2	25.8	15.0	28.5	10.5	22.3	18.7	24.7	14.6	27.3	10.1
	27	25.3	23.5	27.9	19.4	30.9	15.0	24.5	23.1	26.9	18.9	29.7	14.6	23.5	22.6	25.9	18.5	28.6	14.1	22.6	22.2	24.8	18.0	27.4	13.7
	29	26.1	26.1	28.0	22.8	31.0	18.5	25.3	25.3	27.0	22.3	29.8	18.1	24.5	24.5	26.0	21.9	28.7	17.7	23.7	23.7	24.9	21.4	27.5	17.3
	32	27.5	27.5	28.2	26.3	31.0	22.0	26.7	26.7	27.3	25.8	29.9	21.5	25.9	25.9	26.3	25.4	28.8	21.1	25.0	25.0	25.3	24.9	27.6	20.6
5097	24	25.6	20.8	28.3	16.4	31.2	11.5	24.6	20.4	27.2	15.9	30.0	11.1	23.6	19.9	26.2	15.5	28.8	10.7	22.6	19.4	25.0	15.0	27.6	10.2
	27	25.8	24.6	28.3	20.1	31.3	15.4	24.9	24.1	27.3	19.6	30.1	15.0	24.0	23.7	26.2	19.1	28.9	14.5	22.9	22.9	25.1	18.6	27.7	14.1
	29	26.8	26.8	28.5	23.7	31.4	19.2	26.0	26.0	27.4	23.3	30.2	18.8	25.1	25.1	26.4	22.8	29.1	18.4	24.3	24.3	25.3	22.3	27.8	17.8
	32	28.2	28.2	28.7	27.5	31.4	22.8	27.4	27.4	27.8	27.0	30.3	22.4	26.5	26.5	26.8	26.6	29.1	21.9	25.6	25.6	25.7	25.7	27.9	21.5

Equal TGC and SHC values constitute dry coil conditions. Total Gross Cooling (TGC) shown to the left is not applicable. In this case the Sensible Heat Capacity (SHC) is the total capacity.

All capacities shown are gross and have not considered indoor fan heat.
 To obtain net cooling capacities subtract indoor fan heat.
 TGC = Total Gross Cooling Capacity
 SHC = Sensible Heat Capacity



Performance Data

System

Table PD-4 – Gross Cooling Capacities (MBh) TTA085A Condensing Unit with TWE100A Air Handler

(I-P)

CFM		Ambient Temperature (°F)																									
		85						95						105						115							
		Enter. Dry Bulb (°F)		Entering Wet Bulb (°F)												Enter. Dry Bulb (°F)		Entering Wet Bulb (°F)									
Airflow		61	67	73	61	67	73	61	67	73	61	67	73	61	67	73	61	67	73	61	67	73					
2500	75	87.7	68.7	97.0	57.2	107.1	39.2	84.5	67.1	93.5	55.8	103.1	37.9	81.1	65.4	89.8	54.3	98.9	36.4	77.6	63.7	86.0	52.7	94.6	35.0		
	80	88.0	80.1	97.3	66.3	107.2	51.4	84.9	78.5	93.8	64.8	103.4	49.9	81.6	76.9	90.1	63.2	99.3	48.4	78.2	75.1	86.1	61.3	95.1	46.9		
	85	89.8	89.8	97.5	77.6	107.6	63.2	87.2	87.2	94.0	76.0	103.7	61.7	84.4	84.4	90.3	74.3	99.7	60.2	81.5	81.5	86.5	72.7	95.5	58.7		
	90	94.4	94.4	97.9	89.0	107.8	74.9	91.7	91.7	94.4	87.4	103.9	73.5	88.9	88.9	90.9	85.8	99.8	71.6	85.9	85.9	87.3	84.2	95.6	70.0		
2800	75	89.6	72.2	99.1	56.7	109.0	40.0	86.3	70.6	95.4	55.2	104.9	38.6	82.8	68.9	91.6	53.6	100.5	37.2	79.2	67.1	87.6	52.0	96.0	35.6		
	80	90.2	84.8	99.4	69.7	109.3	53.3	87.0	83.2	95.5	67.8	105.3	51.8	83.7	81.6	91.7	66.2	101.1	50.3	80.2	79.9	87.8	64.4	96.7	48.7		
	85	93.1	93.1	99.5	81.9	109.6	66.3	90.4	90.4	95.9	80.3	105.6	64.8	87.4	87.4	92.1	78.6	101.5	63.3	84.4	84.4	88.2	76.9	97.1	61.7		
	90	98.0	98.0	100.2	94.6	109.7	78.8	95.1	95.1	96.7	93.0	105.7	77.2	92.1	92.1	93.1	91.4	101.6	75.6	89.0	89.0	89.1	89.1	97.3	73.9		
3100	75	91.2	75.5	100.7	58.8	110.5	40.8	87.8	73.9	96.9	57.3	106.2	39.4	84.2	72.1	93.0	55.7	101.8	37.9	80.5	70.3	88.9	54.1	97.2	36.3		
	80	92.1	89.4	100.9	72.5	111.0	55.1	88.9	87.8	97.1	70.8	106.8	53.6	85.2	85.2	93.2	69.1	102.5	52.1	82.1	82.1	89.2	67.4	98.1	50.5		
	85	96.1	96.1	101.2	86.1	111.3	69.2	93.1	93.1	97.5	84.5	107.2	67.7	90.1	90.1	93.7	82.8	102.9	66.2	86.9	86.9	89.7	81.1	98.3	64.1		
	90	101.1	101.1	102.3	100.0	111.5	82.7	98.1	98.1	98.8	98.5	107.4	81.1	94.9	94.9	95.0	95.0	103.1	79.5	91.6	91.6	91.7	91.7	98.7	77.8		
3400	75	92.6	78.7	102.1	60.8	111.8	41.5	89.1	77.0	98.2	59.2	107.4	40.0	85.5	75.3	94.2	57.6	102.9	38.4	81.7	73.5	90.0	56.0	98.2	36.8		
	80	93.9	93.8	102.3	75.4	112.4	56.8	90.5	90.5	98.5	73.7	108.1	55.3	87.4	87.4	94.5	72.0	103.7	53.8	84.1	84.1	90.3	70.2	99.2	52.2		
	85	98.6	98.6	102.7	90.1	112.8	72.0	95.6	95.6	99.0	88.5	108.3	70.1	92.4	92.4	95.0	86.8	104.0	68.5	89.0	89.0	91.0	85.1	99.4	66.7		
	90	103.8	103.8	103.9	103.9	112.9	86.4	100.7	100.7	100.8	100.8	108.7	84.8	97.4	97.4	97.5	97.5	104.4	83.2	94.0	94.0	94.0	94.0	99.9	81.4		

Equal TGC and SHC values constitute dry coil conditions. Total Gross Cooling (TGC) shown to the left is not applicable. In this case the Sensible Heat Capacity (SHC) is the total capacity.

All capacities shown are gross and have not considered indoor fan heat.
 To obtain net cooling capacities subtract indoor fan heat.
 TGC = Total Gross Cooling Capacity
 SHC = Sensible Heat Capacity

Table PD-4 – Gross Cooling Capacities (kW) TTA085A Condensing Unit with TWE100A Air Handler

(SI)

m³/h		Ambient Temperature (°C)																							
		29.4				35.0				40.6				46.1											
		Enter. Dry Bulb (°C)		Entering Wet Bulb (°C)										Enter. Dry Bulb (°C)		Entering Wet Bulb (°C)									
Airflow		16.1	19.4	22.8	16.1	19.4	22.8	16.1	19.4	22.8	16.1	19.4	22.8	16.1	19.4	22.8	16.1	19.4	22.8	16.1	19.4	22.8			
4248	24	25.7	20.1	28.4	16.7	31.4	11.5	24.7	19.6	27.4	16.3	30.2	11.1	23.7	19.2	26.3	15.9	29.0	10.7	22.7	18.6	25.2	15.4	27.7	10.2
	27	25.8	23.4	28.5	19.4	31.4	15.1	24.9	23.0	27.5	19.0	30.3	14.6	23.9	22.5	26.4	18.5	29.1	14.2	22.9	22.0	25.2	18.0	27.9	13.7
	29	26.3	26.3	28.5	22.7	31.5	18.5	25.5	25.5	27.5	22.2	30.4	18.1	24.7	24.7	26.4	21.8	29.2	17.6	23.9	23.9	25.3	21.3	28.0	17.2
	32	27.6	27.6	28.7	26.1	31.6	21.9	26.8	26.8	27.7	25.6	30.4	21.5	26.0	26.0	26.6	25.1	29.2	21.0	25.1	25.1	25.6	24.7	28.0	20.5
4757	24	26.2	21.1	29.0	16.6	31.9	11.7	25.3	20.7	27.9	16.2	30.7	11.3	24.2	20.2	26.8	15.7	29.4	10.9	23.2	19.6	25.6	15.2	28.1	10.4
	27	26.4	24.8	29.1	20.4	32.0	15.6	25.5	24.4	28.0	19.9	30.8	15.2	24.5	23.9	26.9	19.4	29.6	14.7	23.5	23.4	25.7	18.9	28.3	14.3
	29	27.3	27.3	29.1	24.0	32.1	19.4	26.5	26.5	28.1	23.5	30.9	19.0	25.6	25.6	27.0	23.0	29.7	18.5	24.7	24.7	25.8	22.5	28.4	18.1
	32	28.7	28.7	29.3	27.7	32.1	23.1	27.9	27.9	28.3	27.2	31.0	22.6	27.0	27.0	27.3	26.8	29.8	22.1	26.1	26.1	26.1	26.1	28.5	21.7
5267	24	26.7	22.1	29.5	17.2	32.4	12.0	25.7	21.6	28.4	16.8	31.1	11.5	24.7	21.1	27.2	16.3	29.8	11.1	23.6	20.6	26.0	15.8	28.5	10.6
	27	27.0	26.2	29.5	21.2	32.5	16.1	26.0	25.7	28.4	20.7	31.3	15.7	25.0	25.0	27.3	20.2	30.0	15.2	24.0	24.0	26.1	19.7	28.7	14.8
	29	28.1	28.1	29.6	25.2	32.6	20.3	27.3	27.3	28.5	24.7	31.4	19.8	26.4	26.4	27.4	24.2	30.1	19.4	25.4	25.4	26.3	23.7	28.8	18.8
	32	29.6	29.6	30.0	29.3	32.6	24.2	28.7	28.7	28.9	28.8	31.4	23.7	27.8	27.8	27.8	27.8	30.2	23.3	26.8	26.8	26.9	26.9	28.9	22.8
5777	24	27.1	23.1	29.9	17.8	32.7	12.1	26.1	22.6	28.8	17.3	31.5	11.7	25.0	22.0	27.6	16.9	30.1	11.2	23.9	21.5	26.4	16.4	28.8	10.8
	27	27.5	27.5	30.0	22.1	32.9	16.6	26.5	26.5	28.8	21.6	31.7	16.2	25.6	25.6	27.7	21.1	30.4	15.7	24.6	24.6	26.4	20.6	29.0	15.3
	29	28.9	28.9	30.1	26.4	33.0	21.1	28.0	28.0	29.0	25.9	31.7	20.5	27.0	27.0	27.8	25.4	30.4	20.0	26.1	26.1	26.6	24.9	29.1	19.5
	32	30.4	30.4	30.4	30.4	33.1	25.3	29.5	29.5	29.5	29.5	31.8	24.8	28.5	28.5	28.6	28.6	30.6	24.4	27.5	27.5	27.5	27.5	29.2	23.8

Equal TGC and SHC values constitute dry coil conditions. Total Gross Cooling (TGC) shown to the left is not applicable. In this case the Sensible Heat Capacity (SHC) is the total capacity.

All capacities shown are gross and have not considered indoor fan heat.
 To obtain net cooling capacities subtract indoor fan heat.
 TGC = Total Gross Cooling Capacity
 SHC = Sensible Heat Capacity



Performance Data System

Table PD-5 – Gross Cooling Capacities (MBh) TTA100A Condensing Unit with TWE100A Air Handler

(I-P)

		Ambient Temperature (°F)																							
		85						95						105						115					
CFM	Enter. Dry Bulb (°F)	Entering Wet Bulb (°F)																							
		61		67		73		61		67		73		61		67		73		61		67		73	
Airflow	(°F)	TGC	SHC	TGC	SHC	TGC	SHC	TGC	SHC	TGC	SHC	TGC	SHC	TGC	SHC	TGC	SHC	TGC	SHC	TGC	SHC	TGC	SHC	TGC	SHC
3025	75	104.7	81.7	115.8	68.5	127.7	46.8	100.9	79.7	111.5	66.8	123.0	45.1	96.8	77.7	107.1	65.0	118.1	43.5	92.4	75.5	102.5	63.2	112.9	41.7
	80	105.2	95.0	116.1	78.6	127.8	61.1	101.5	93.1	111.9	76.8	123.2	59.3	97.5	91.1	107.5	75.0	118.3	57.5	93.3	89.0	102.9	73.0	113.3	55.6
	85	106.9	106.9	116.3	92.0	128.1	74.9	103.8	103.8	112.1	90.1	123.5	73.1	100.4	100.4	107.7	88.1	118.7	71.3	96.9	96.9	103.1	86.1	113.7	69.5
	90	112.3	112.3	116.8	105.4	128.4	88.7	109.1	109.1	112.7	103.5	123.8	86.9	105.7	105.7	108.4	101.6	119.0	85.1	102.1	102.1	104.1	99.7	113.8	82.9
3350	75	106.8	85.3	118.0	67.1	129.8	47.6	102.8	83.3	113.6	65.3	124.9	46.0	98.6	81.2	109.0	63.4	119.8	44.2	94.2	79.1	104.3	61.5	114.5	42.4
	80	107.5	99.9	118.3	82.1	130.0	63.0	103.7	98.0	113.9	80.3	125.2	61.2	99.6	96.0	109.4	78.4	120.2	59.4	95.4	93.9	104.5	76.0	115.0	57.5
	85	110.4	110.4	118.4	96.5	130.3	78.1	107.1	107.1	114.1	94.6	125.5	76.3	103.7	103.7	109.6	92.6	120.6	74.5	100.0	100.0	104.9	90.5	115.4	72.6
	90	116.1	116.1	119.2	111.2	130.5	93.1	112.7	112.7	115.0	109.3	125.6	90.9	109.1	109.1	110.7	107.4	120.7	89.0	105.4	105.4	106.3	105.4	115.6	87.0
3675	75	108.6	88.8	119.7	69.3	131.5	48.5	104.5	86.8	115.2	67.4	126.5	46.8	100.2	84.7	110.6	65.5	121.2	44.9	95.6	82.4	105.7	63.5	115.8	43.0
	80	109.5	104.7	120.1	85.4	131.7	64.8	105.6	102.7	115.4	83.2	126.8	63.1	101.6	100.7	110.8	81.2	121.7	61.2	97.0	97.0	105.9	79.1	116.4	59.3
	85	113.5	113.5	120.3	100.8	132.1	81.1	110.1	110.1	115.8	98.8	127.2	79.3	106.4	106.4	111.2	96.8	122.1	77.5	102.6	102.6	106.5	94.8	116.8	75.6
	90	119.4	119.4	121.4	116.8	132.2	96.8	115.8	115.8	117.2	114.9	127.3	94.9	112.1	112.1	112.2	112.2	122.3	92.9	108.2	108.2	108.3	108.3	117.0	90.9
4000	75	110.1	92.1	121.2	71.3	132.9	49.2	105.9	90.0	116.6	69.4	127.8	47.4	101.5	87.9	111.9	67.5	122.4	45.5	96.9	85.7	106.9	65.6	116.8	43.6
	80	111.4	109.2	121.4	88.2	133.2	66.6	107.5	107.3	116.9	86.2	128.2	64.8	103.1	103.1	112.1	84.2	123.0	63.0	99.3	99.3	107.2	82.0	117.6	61.1
	85	116.3	116.3	121.9	105.0	133.6	84.0	112.7	112.7	117.4	103.0	128.6	82.2	108.9	108.9	112.7	101.0	123.4	80.4	105.0	105.0	107.9	98.9	117.8	78.0
	90	122.3	122.3	123.5	122.3	133.8	100.7	118.6	118.6	118.7	118.7	128.8	98.7	114.7	114.7	114.8	114.8	123.7	96.8	110.7	110.7	110.8	110.8	118.3	94.7

Equal TGC and SHC values constitute dry coil conditions. Total Gross Cooling (TGC) shown to the left is not applicable. In this case the Sensible Heat Capacity (SHC) is the total capacity.

All capacities shown are gross and have not considered indoor fan heat.
 To obtain net cooling capacities subtract indoor fan heat.
 TGC = Total Gross Cooling Capacity
 SHC = Sensible Heat Capacity

Table PD-5 – Gross Cooling Capacities (kW) TTA100A Condensing Unit with TWE100A Air Handler

(SI)

		Ambient Temperature (°C)																							
		29.4				35.0				40.6				46.1											
m³/h	Enter. Dry Bulb (°C)	Entering Wet Bulb (°C)																							
		16.1		19.4		22.8		16.1		19.4		22.8		16.1		19.4		22.8							
Airflow	(°C)	TGC	SHC	TGC	SHC	TGC	SHC	TGC	SHC	TGC	SHC	TGC	SHC	TGC	SHC	TGC	SHC	TGC	SHC	TGC	SHC				
5139	24	30.7	23.9	33.9	20.1	37.4	13.7	29.5	23.3	32.7	19.6	36.0	13.2	28.3	22.7	31.4	19.0	34.6	12.7	27.1	22.1	30.0	18.5	33.1	12.2
	27	30.8	27.8	34.0	23.0	37.4	17.9	29.7	27.3	32.8	22.5	36.1	17.4	28.5	26.7	31.5	22.0	34.6	16.8	27.3	26.1	30.1	21.4	33.2	16.3
	29	31.3	31.3	34.0	26.9	37.5	21.9	30.4	30.4	32.8	26.4	36.2	21.4	29.4	29.4	31.5	25.8	34.7	20.9	28.4	28.4	30.2	25.2	33.3	20.3
	32	32.9	32.9	34.2	30.9	37.6	26.0	31.9	31.9	33.0	30.3	36.2	25.5	30.9	30.9	31.8	29.8	34.8	24.9	29.9	29.9	30.5	29.2	33.3	24.3
5692	24	31.3	25.0	34.5	19.7	38.0	13.9	30.1	24.4	33.3	19.1	36.6	13.5	28.9	23.8	31.9	18.6	35.1	12.9	27.6	23.1	30.5	18.0	33.5	12.4
	27	31.5	29.3	34.6	24.0	38.1	18.5	30.3	28.7	33.4	23.5	36.7	17.9	29.2	28.1	32.0	23.0	35.2	17.4	27.9	27.5	30.6	22.3	33.7	16.8
	29	32.3	32.3	34.7	28.3	38.1	22.9	31.4	31.4	33.4	27.7	36.8	22.3	30.3	30.3	32.1	27.1	35.3	21.8	29.3	29.3	30.7	26.5	33.8	21.3
	32	34.0	34.0	34.9	32.6	38.2	27.2	33.0	33.0	33.7	32.0	36.8	26.6	31.9	31.9	32.4	31.4	35.3	26.1	30.9	30.9	31.1	30.9	33.8	25.5
6244	24	31.8	26.0	35.1	20.3	38.5	14.2	30.6	25.4	33.7	19.7	37.0	13.7	29.3	24.8	32.4	19.2	35.5	13.2	28.0	24.1	30.9	18.6	33.9	12.6
	27	32.1	30.6	35.2	25.0	38.6	19.0	30.9	30.1	33.8	24.4	37.1	18.5	29.7	29.5	32.4	23.8	35.6	17.9	28.4	28.4	31.0	23.2	34.1	17.4
	29	33.2	33.2	35.2	29.5	38.7	23.7	32.2	32.2	33.9	28.9	37.2	23.2	31.2	31.2	32.6	28.4	35.8	22.7	30.0	30.0	31.2	27.8	34.2	22.1
	32	35.0	35.0	35.6	34.2	38.7	28.3	33.9	33.9	34.3	33.7	37.3	27.8	32.8	32.8	32.8	32.8	35.8	27.2	31.7	31.7	31.7	31.7	34.3	26.6
6796	24	32.2	27.0	35.5	20.9	38.9	14.4	31.0	26.4	34.2	20.3	37.4	13.9	29.7	25.7	32.8	19.8	35.8	13.3	28.4	25.1	31.3	19.2	34.2	12.8
	27	32.6	32.0	35.6	25.8	39.0	19.5	31.5	31.4	34.2	25.2	37.5	19.0	30.2	30.2	32.8	24.6	36.0	18.4	29.1	29.1	31.4	24.0	34.4	17.9
	29	34.0	34.0	35.7	30.7	39.1	24.6	33.0	33.0	34.4	30.2	37.7	24.1	31.9	31.9	33.0	29.6	36.1	23.5	30.7	30.7	31.6	29.0	34.5	22.8
	32	35.8	35.8	36.2	35.8	39.2	29.5	34.7	34.7	34.8	34.8	37.7	28.9	33.6	33.6	33.6	33.6	36.2	28.3	32.4	32.4	32.4	32.4	34.6	27.7

Equal TGC and SHC values constitute dry coil conditions. Total Gross Cooling (TGC) shown to the left is not applicable. In this case the Sensible Heat Capacity (SHC) is the total capacity.

All capacities shown are gross and have not considered indoor fan heat.
 To obtain net cooling capacities subtract indoor fan heat.
 TGC = Total Gross Cooling Capacity
 SHC = Sensible Heat Capacity



Performance Data

System

Table PD-6 — Gross Cooling Capacities (MBh) TTA100B Condensing Unit with TWE100B Air Handler (I-P)

CFM		Ambient Temperature (°F)																							
		85						95						105						115					
		Enter. Dry Bulb (°F)		Entering Wet Bulb (°F)																					
Airflow		61	67	73		61	67	73		61	67	73		61	67	73		61	67	73		61	67	73	
3025	75	103.0	80.9	114.1	68.0	125.6	46.6	99.4	79.0	110.0	66.4	120.7	44.9	95.6	77.1	105.7	64.6	115.6	43.2	91.7	75.1	101.3	62.8	110.3	41.3
	80	103.7	94.4	114.8	78.7	126.6	61.2	100.2	92.5	110.3	76.3	122.0	59.4	96.5	90.6	106.1	74.4	117.2	57.6	92.7	88.6	101.7	72.3	112.0	55.7
	85	105.9	105.9	115.1	91.6	127.3	75.2	102.9	102.9	111.1	89.7	122.8	73.5	99.7	99.7	106.8	87.7	118.0	71.7	96.4	96.4	102.4	85.7	112.9	69.8
	90	111.5	111.5	115.8	105.1	127.4	88.5	108.4	108.4	111.9	103.3	123.0	86.7	105.2	105.2	107.8	101.3	118.3	84.7	101.7	101.7	103.5	99.3	113.3	82.6
3350	75	105.2	84.5	116.3	67.0	127.5	47.3	101.4	82.6	112.1	65.2	122.5	45.6	97.5	80.6	107.6	63.4	117.2	43.8	93.4	78.5	103.0	61.5	111.7	41.9
	80	106.1	99.2	116.6	81.5	128.8	63.2	102.4	97.3	112.4	79.6	124.0	61.4	98.6	95.4	108.1	77.5	119.0	59.6	94.7	93.4	103.5	75.4	113.7	57.7
	85	109.5	109.5	117.4	96.1	129.6	78.5	106.3	106.3	113.2	94.2	124.9	76.7	103.0	103.0	108.8	92.2	120.0	74.9	99.5	99.5	104.2	90.0	114.2	72.1
	90	115.4	115.4	118.3	110.9	129.8	92.7	112.1	112.1	114.3	109.0	125.2	90.8	108.7	108.7	110.1	107.1	120.4	88.8	105.0	105.0	105.8	105.1	115.2	86.7
3675	75	107.0	87.9	118.1	69.2	129.0	48.1	103.0	85.9	113.7	67.4	123.9	46.4	99.0	83.9	109.1	65.5	118.5	44.6	94.8	81.8	103.6	62.8	112.8	42.7
	80	108.2	103.9	118.6	84.6	130.6	65.1	104.4	102.0	114.3	82.6	125.8	63.3	100.6	100.0	109.7	80.6	120.6	61.5	96.5	96.5	105.0	78.4	115.1	59.5
	85	112.6	112.6	119.3	100.4	131.5	81.5	109.3	109.3	115.0	98.4	126.2	79.0	105.8	105.8	110.5	96.4	121.1	76.9	102.1	102.1	105.9	94.3	115.8	74.7
	90	118.8	118.8	120.7	116.5	131.8	96.7	115.4	115.4	116.6	114.6	127.2	94.8	111.7	111.7	111.8	111.8	122.1	92.7	107.8	107.8	107.9	107.9	116.8	90.6
4000	75	108.5	91.2	119.7	71.3	130.4	48.9	104.5	89.2	115.2	69.5	125.1	47.2	100.4	87.1	109.7	66.6	119.5	45.2	96.1	84.9	104.9	64.4	113.6	43.3
	80	110.1	108.5	120.2	87.6	132.2	66.9	105.8	105.8	115.8	85.6	127.2	65.1	102.3	102.3	111.2	83.5	121.9	63.2	98.6	98.6	106.3	81.2	116.3	61.3
	85	115.5	115.5	121.0	104.5	132.6	83.7	112.0	112.0	116.7	102.6	127.8	79.6	108.3	108.3	112.1	100.5	122.6	79.6	104.4	104.4	107.3	98.3	117.1	77.3
	90	121.8	121.8	122.8	121.9	133.5	100.5	118.2	118.2	118.3	118.3	128.8	98.6	114.4	114.4	114.5	114.5	123.6	96.5	110.4	110.4	110.5	110.5	118.2	94.3

Equal TGC and SHC values constitute dry coil conditions. Total Gross Cooling (TGC) shown to the left is not applicable. In this case the Sensible Heat Capacity (SHC) is the total capacity.

All capacities shown are gross and have not considered indoor fan heat.
 To obtain net cooling capacities subtract indoor fan heat.
 TGC = Total Gross Cooling Capacity
 SHC = Sensible Heat Capacity

Table PD-6 — Gross Cooling Capacities (kW) TTA100B Condensing Unit with TWE100B Air Handler (SI)

m³/h		Ambient Temperature (°C)																							
		29.4				35.0				40.6				46.1											
		Enter. Dry Bulb (°C)		Entering Wet Bulb (°C)																					
Airflow		16.1	19.4	22.8		16.1	19.4	22.8		16.1	19.4	22.8		16.1	19.4	22.8									
5139	24	30.2	23.7	33.4	19.9	36.8	13.6	29.1	23.1	32.2	19.4	35.3	13.1	28.0	22.6	31.0	18.9	33.9	12.6	26.9	22.0	29.7	18.4	32.3	12.1
	27	30.4	27.6	33.6	23.0	37.1	17.9	29.3	27.1	32.3	22.4	35.7	17.4	28.3	26.5	31.1	21.8	34.3	16.9	27.1	25.9	29.8	21.2	32.8	16.3
	29	31.0	31.0	33.7	26.8	37.3	22.0	30.1	30.1	32.5	26.3	36.0	21.5	29.2	29.2	31.3	25.7	34.6	21.0	28.2	28.2	30.0	25.1	33.1	20.4
	32	32.7	32.7	33.9	30.8	37.3	25.9	31.8	31.8	32.8	30.2	36.0	25.4	30.8	30.8	31.5	29.7	34.6	24.8	29.8	29.8	30.3	29.1	33.2	24.2
5692	24	30.8	24.7	34.1	19.6	37.3	13.8	29.7	24.2	32.8	19.1	35.9	13.4	28.5	23.6	31.5	18.6	34.3	12.8	27.3	23.0	30.1	18.0	32.7	12.3
	27	31.1	29.1	34.1	23.9	37.7	18.5	30.0	28.5	32.9	23.3	36.3	18.0	28.9	27.9	31.6	22.7	34.9	17.5	27.7	27.3	30.3	22.1	33.3	16.9
	29	32.1	32.1	34.4	28.1	37.9	23.0	31.1	31.1	33.2	27.6	36.6	22.5	30.1	30.1	31.9	27.0	35.1	21.9	29.1	29.1	30.5	26.4	33.4	21.1
	32	33.8	33.8	34.6	32.5	38.0	27.1	32.8	32.8	33.5	31.9	36.7	26.6	31.8	31.8	32.3	31.4	35.2	26.0	30.7	30.7	31.0	30.8	33.7	25.4
6244	24	31.3	25.7	34.6	20.3	37.8	14.1	30.2	25.2	33.3	19.7	36.3	13.6	29.0	24.6	32.0	19.2	34.7	13.1	27.8	23.9	30.3	18.4	33.0	12.5
	27	31.7	30.4	34.7	24.8	38.2	19.1	30.6	29.9	33.5	24.2	36.8	18.5	29.5	29.3	32.1	23.6	35.3	18.0	28.2	28.2	30.7	23.0	33.7	17.4
	29	33.0	33.0	34.9	29.4	38.5	23.9	32.0	32.0	33.7	28.8	36.9	23.1	31.0	31.0	32.4	28.2	35.5	22.5	29.9	29.9	31.0	27.6	33.9	21.9
	32	34.8	34.8	35.3	34.1	38.6	28.3	33.8	33.8	34.1	33.6	37.2	27.8	32.7	32.7	32.7	32.7	35.8	27.1	31.6	31.6	31.6	31.6	34.2	26.5
6796	24	31.8	26.7	35.0	20.9	38.2	14.3	30.6	26.1	33.7	20.3	36.6	13.8	29.4	25.5	32.1	19.5	35.0	13.2	28.1	24.9	30.7	18.9	33.3	12.7
	27	32.2	31.8	35.2	25.7	38.7	19.6	31.0	31.0	33.9	25.1	37.3	19.1	30.0	30.0	32.5	24.4	35.7	18.5	28.9	28.9	31.1	23.8	34.0	17.9
	29	33.8	33.8	35.4	30.6	38.8	24.5	32.8	32.8	34.2	30.0	37.4	23.9	31.7	31.7	32.8	29.4	35.9	23.3	30.6	30.6	31.4	28.8	34.3	22.6
	32	35.7	35.7	36.0	35.7	39.1	29.4	34.6	34.6	34.6	34.6	37.7	28.9	33.5	33.5	33.5	33.5	36.2	28.3	32.3	32.3	32.3	32.3	34.6	27.6

Equal TGC and SHC values constitute dry coil conditions. Total Gross Cooling (TGC) shown to the left is not applicable. In this case the Sensible Heat Capacity (SHC) is the total capacity.

All capacities shown are gross and have not considered indoor fan heat.
 To obtain net cooling capacities subtract indoor fan heat.
 TGC = Total Gross Cooling Capacity
 SHC = Sensible Heat Capacity



Performance Data System

Table PD-7 – Gross Cooling Capacities (MBh) - Both Compressors - TTA100C Condensing Unit with TWE100A Air Handler (I-P)

CFM		Ambient Temperature (°F)																							
		85						95						105						115					
		Enter. Dry Bulb		Entering Wet Bulb (°F)																					
Airflow	(°F)	TGC	SHC	TGC	SHC	TGC	SHC	TGC	SHC	TGC	SHC	TGC	SHC	TGC	SHC	TGC	SHC	TGC	SHC	TGC	SHC	TGC	SHC		
3025	75	103.7	81.4	114.8	68.3	126.3	46.7	100.1	79.6	110.8	66.7	121.8	45.1	96.3	77.6	106.5	65.0	116.9	43.5	92.3	75.6	102.0	63.2	111.6	41.7
	80	104.3	94.9	115.3	78.8	126.8	61.2	100.8	93.0	111.3	77.1	122.4	59.5	97.1	91.1	107.1	75.3	117.7	57.8	93.3	89.2	102.4	72.8	112.7	55.9
	85	106.4	106.4	115.5	92.0	127.3	75.1	103.5	103.5	111.6	90.2	123.0	73.5	100.3	100.3	107.4	88.2	118.4	71.8	97.0	97.0	103.0	86.2	113.4	69.9
	90	112.0	112.0	116.2	105.5	127.6	89.0	108.9	108.9	112.3	103.7	123.1	86.9	105.7	105.7	108.3	101.8	118.5	85.0	102.2	102.2	104.0	99.9	113.6	83.0
3350	75	105.8	85.0	117.0	67.2	128.2	47.5	102.1	83.1	112.8	65.5	123.5	45.9	98.1	81.2	108.4	63.6	118.5	44.1	94.0	79.1	103.8	61.7	113.1	42.3
	80	106.7	99.8	117.5	82.4	128.9	63.1	103.1	97.9	113.0	80.1	124.4	61.5	99.3	96.0	108.7	78.1	119.6	59.7	95.4	94.0	104.1	76.0	114.4	57.8
	85	110.0	110.0	117.7	96.5	129.4	78.3	106.9	106.9	113.7	94.6	125.0	76.7	103.5	103.5	109.3	92.7	120.2	74.9	100.0	100.0	104.8	90.6	115.1	73.1
	90	115.8	115.8	118.6	111.3	129.5	92.8	112.5	112.5	114.8	109.5	125.1	91.0	109.1	109.1	110.6	107.6	120.4	89.1	105.4	105.4	106.3	105.6	115.4	87.1
3675	75	107.6	88.5	118.8	69.4	129.7	48.3	103.7	86.6	114.5	67.6	125.0	46.7	99.7	84.5	109.9	65.8	119.8	44.9	95.5	82.4	105.2	63.9	114.2	43.0
	80	108.8	104.5	119.0	85.1	130.6	65.0	105.1	102.7	114.8	83.2	126.0	63.3	101.3	100.7	110.3	81.1	121.1	61.5	97.0	97.0	105.6	79.0	115.8	59.6
	85	113.1	113.1	119.6	100.8	131.2	81.4	109.8	109.8	115.4	98.9	126.6	79.7	106.3	106.3	111.0	96.9	121.7	77.9	102.6	102.6	106.4	94.8	116.1	75.2
	90	119.0	119.0	120.9	116.9	131.4	96.8	115.7	115.7	117.0	115.1	126.9	95.0	112.1	112.1	112.2	112.2	122.0	93.0	108.2	108.2	108.3	108.3	116.9	90.9
4000	75	109.1	91.8	120.2	71.5	131.1	49.1	105.2	89.8	115.9	69.7	126.2	47.4	101.1	87.8	111.2	67.8	120.9	45.5	96.8	85.6	105.8	65.1	115.2	43.6
	80	110.7	109.1	120.6	88.0	132.1	66.8	106.4	106.4	116.3	86.1	127.4	65.1	102.9	102.9	111.7	84.1	122.4	63.3	99.2	99.2	106.9	81.9	116.9	61.4
	85	115.9	115.9	121.2	104.9	132.7	84.3	112.5	112.5	117.0	103.1	127.7	81.9	108.8	108.8	112.6	101.1	122.7	80.0	105.0	105.0	107.9	98.9	117.4	77.8
	90	121.9	121.9	123.0	122.3	133.0	100.6	118.5	118.5	118.6	118.6	128.3	98.8	114.8	114.8	114.9	114.9	123.4	96.8	110.7	110.7	110.8	110.8	118.1	94.7

Equal TGC and SHC values constitute dry coil conditions. Total Gross Cooling (TGC) shown to the left is not applicable. In this case the Sensible Heat Capacity (SHC) is the total capacity.

All capacities shown are gross and have not considered indoor fan heat.
 To obtain net cooling capacities subtract indoor fan heat.
 TGC = Total Gross Cooling Capacity
 SHC = Sensible Heat Capacity

Table PD-7 – Gross Cooling Capacities (kW) - Both Compressors - TTA100C Condensing Unit with TWE100A Air Handler (SI)

m³/h		Ambient Temperature (°C)																							
		29.4				35.0				40.6				46.1											
		Enter. Dry Bulb		Entering Wet Bulb (°C)																					
Airflow	(°C)	TGC	SHC	TGC	SHC	TGC	SHC	TGC	SHC	TGC	SHC	TGC	SHC	TGC	SHC	TGC	SHC	TGC	SHC	TGC	SHC				
5139	24	30.4	23.8	33.6	20.0	37.0	13.7	29.3	23.3	32.4	19.5	35.7	13.2	28.2	22.7	31.2	19.0	34.2	12.7	27.0	22.1	29.9	18.5	32.7	12.2
	27	30.5	27.8	33.8	23.1	37.1	17.9	29.5	27.2	32.6	22.6	35.8	17.4	28.4	26.7	31.4	22.1	34.5	16.9	27.3	26.1	30.0	21.3	33.0	16.4
	29	31.2	31.2	33.8	26.9	37.3	22.0	30.3	30.3	32.7	26.4	36.0	21.5	29.4	29.4	31.4	25.8	34.7	21.0	28.4	28.4	30.2	25.2	33.2	20.5
	32	32.8	32.8	34.0	30.9	37.4	26.1	31.9	31.9	32.9	30.4	36.0	25.4	30.9	30.9	31.7	29.8	34.7	24.9	29.9	29.9	30.5	29.2	33.3	24.3
5692	24	31.0	24.9	34.3	19.7	37.5	13.9	29.9	24.3	33.0	19.2	36.2	13.4	28.7	23.8	31.7	18.6	34.7	12.9	27.5	23.2	30.4	18.1	33.1	12.4
	27	31.2	29.2	34.4	24.1	37.7	18.5	30.2	28.7	33.1	23.4	36.4	18.0	29.1	28.1	31.8	22.9	35.0	17.5	27.9	27.5	30.5	22.3	33.5	16.9
	29	32.2	32.2	34.5	28.2	37.9	22.9	31.3	31.3	33.3	27.7	36.6	22.4	30.3	30.3	32.0	27.1	35.2	21.9	29.3	29.3	30.7	26.5	33.7	21.4
	32	33.9	33.9	34.7	32.6	37.9	27.2	33.0	33.0	33.6	32.1	36.6	26.6	31.9	31.9	32.4	31.5	35.3	26.1	30.9	30.9	31.1	30.9	33.8	25.5
6244	24	31.5	25.9	34.8	20.3	38.0	14.1	30.4	25.3	33.5	19.8	36.6	13.7	29.2	24.7	32.2	19.3	35.1	13.2	28.0	24.1	30.8	18.7	33.4	12.6
	27	31.9	30.6	34.8	24.9	38.2	19.0	30.8	30.1	33.6	24.3	36.9	18.5	29.7	29.5	32.3	23.8	35.5	18.0	28.4	28.4	30.9	23.1	33.9	17.5
	29	33.1	33.1	35.0	29.5	38.4	23.8	32.2	32.2	33.8	29.0	37.1	23.3	31.1	31.1	32.5	28.4	35.6	22.8	30.1	30.1	31.2	27.8	34.0	22.0
	32	34.8	34.8	35.4	34.2	38.5	28.3	33.9	33.9	34.2	33.7	37.1	27.8	32.8	32.8	32.8	32.8	35.7	27.2	31.7	31.7	31.7	31.7	34.2	26.6
6796	24	32.0	26.9	35.2	20.9	38.4	14.4	30.8	26.3	33.9	20.4	37.0	13.9	29.6	25.7	32.6	19.9	35.4	13.3	28.3	25.1	31.0	19.1	33.7	12.8
	27	32.4	32.0	35.3	25.8	38.7	19.5	31.2	31.2	34.1	25.2	37.3	19.1	30.1	30.1	32.7	24.6	35.8	18.5	29.1	29.1	31.3	24.0	34.2	18.0
	29	33.9	33.9	35.5	30.7	38.9	24.7	32.9	32.9	34.3	30.2	37.4	24.0	31.9	31.9	33.0	29.6	35.9	23.4	30.7	30.7	31.6	29.0	34.4	22.8
	32	35.7	35.7	36.0	35.8	38.9	29.5	34.7	34.7	34.7	34.7	37.6	28.9	33.6	33.6	33.6	33.6	36.1	28.3	32.4	32.4	32.5	32.5	34.6	27.7

Equal TGC and SHC values constitute dry coil conditions. Total Gross Cooling (TGC) shown to the left is not applicable. In this case the Sensible Heat Capacity (SHC) is the total capacity.

All capacities shown are gross and have not considered indoor fan heat.
 To obtain net cooling capacities subtract indoor fan heat.
 TGC = Total Gross Cooling Capacity
 SHC = Sensible Heat Capacity



Performance Data

System

Table PD-8 — Gross Cooling Capacities (MBh) - Single Compressor - TTA100C Condensing Unit with TWE100A Air Handler (I-P)

CFM		Ambient Temperature (°F)																							
		85						95						105						115					
		Enter. Dry Bulb (°F)		Entering Wet Bulb (°F)																					
Airflow		61	67	73	61	67	73	61	67	73	61	67	73	61	67	73	61	67	73	61	67	73			
3025	75	63.8	62.6	69.8	46.0	76.2	29.7	61.3	61.3	67.2	45.0	73.4	28.6	59.2	59.2	64.6	43.8	70.4	27.7	57.0	57.0	61.8	42.6	67.1	26.6
	80	67.3	67.3	70.1	59.5	76.9	43.1	65.2	65.2	67.6	58.5	74.0	41.8	63.0	63.0	65.0	57.4	71.1	40.7	60.7	60.7	62.2	56.3	68.1	40.8
	85	71.2	71.2	71.3	71.3	77.1	56.3	69.1	69.1	69.2	69.2	74.4	55.3	66.8	66.8	66.9	66.9	71.5	54.2	64.4	64.4	64.5	64.5	68.5	53.1
	90	75.2	75.2	75.3	75.3	77.5	69.9	73.0	73.0	73.1	73.1	74.8	69.0	70.7	70.7	70.8	70.8	72.0	67.9	68.2	68.2	68.3	68.3	69.1	66.8
3350	75	64.8	64.8	70.6	48.6	76.9	29.7	62.7	62.7	67.9	46.8	74.0	28.7	60.5	60.5	65.2	45.7	70.9	27.7	58.2	58.2	62.4	44.4	67.5	26.7
	80	68.8	68.8	70.9	62.7	77.7	44.9	66.7	66.7	68.4	61.6	74.8	44.0	64.4	64.4	65.7	60.5	71.9	43.0	62.0	62.0	63.0	59.4	68.7	42.0
	85	72.9	72.9	73.0	73.0	77.9	59.1	70.7	70.7	70.8	70.8	75.1	58.1	68.4	68.4	68.4	68.4	72.2	57.0	65.9	65.9	65.9	65.9	69.1	55.9
	90	77.0	77.0	77.1	77.1	78.4	74.0	74.7	74.7	74.8	74.8	75.7	73.0	72.3	72.3	72.4	72.4	73.0	72.0	69.7	69.7	69.8	69.8	69.8	69.8
3675	75	66.0	66.0	71.2	49.7	77.4	30.2	63.9	63.9	68.5	48.6	74.4	29.2	61.6	61.6	65.8	47.4	71.2	28.2	59.3	59.3	62.9	46.2	67.8	27.2
	80	70.2	70.2	71.7	65.7	78.3	46.7	68.0	68.0	69.1	64.6	75.4	45.7	65.6	65.6	66.4	63.5	72.4	44.8	63.1	63.1	63.6	62.3	69.2	43.7
	85	74.4	74.4	74.4	74.4	78.6	61.9	72.1	72.1	72.1	72.1	75.7	60.8	69.7	69.7	69.7	69.7	72.8	59.8	67.1	67.1	67.1	67.1	69.6	58.6
	90	78.6	78.6	78.7	78.7	79.3	78.0	76.2	76.2	76.3	76.3	76.3	76.3	73.7	73.7	73.8	73.8	73.8	73.8	71.0	71.0	71.1	71.1	71.1	71.1
4000	75	67.1	67.1	71.7	51.4	77.8	30.7	64.9	64.9	69.1	50.3	74.7	29.7	62.6	62.6	66.3	49.1	71.5	28.7	60.2	60.2	63.3	47.8	68.0	27.6
	80	71.4	71.4	72.3	68.6	78.8	48.3	69.1	69.1	69.8	67.5	75.9	47.4	66.7	66.7	67.1	66.4	72.9	46.4	64.1	64.1	64.2	64.2	69.6	45.4
	85	75.6	75.6	75.7	75.7	79.1	64.5	73.3	73.3	73.3	73.3	76.2	63.5	70.8	70.8	70.9	70.9	73.3	62.4	68.1	68.1	68.2	68.2	70.1	61.2
	90	79.9	79.9	80.0	80.0	80.1	80.1	77.5	77.5	77.6	77.6	77.6	77.6	74.9	74.9	75.0	75.0	75.0	75.0	72.1	72.1	72.2	72.2	72.3	72.3

Equal TGC and SHC values constitute dry coil conditions. Total Gross Cooling (TGC) shown to the left is not applicable. In this case the Sensible Heat Capacity (SHC) is the total capacity.

All capacities shown are gross and have not considered indoor fan heat.
 To obtain net cooling capacities subtract indoor fan heat.
 TGC = Total Gross Cooling Capacity
 SHC = Sensible Heat Capacity

Table PD-8 — Gross Cooling Capacities (kW) - Single Compressor - TTA100C Condensing Unit with TWE100A Air Handler (SI)

m³/h		Ambient Temperature (°C)																							
		29.4				35.0				40.6				46.1											
		Enter. Dry Bulb (°C)		Entering Wet Bulb (°C)																					
Airflow		16.1	19.4	22.8	16.1	19.4	22.8	16.1	19.4	22.8	16.1	19.4	22.8	16.1	19.4	22.8									
5139	24	18.7	18.3	20.4	13.5	22.3	8.7	18.0	18.0	19.7	13.2	21.5	8.4	17.3	17.3	18.9	12.8	20.6	8.1	16.7	16.7	18.1	12.5	19.7	7.8
	27	19.7	19.7	20.5	17.4	22.5	12.6	19.1	19.1	19.8	17.1	21.7	12.2	18.5	18.5	19.0	16.8	20.8	11.9	17.8	17.8	18.2	16.5	19.9	11.9
	29	20.9	20.9	20.9	20.9	22.6	16.5	20.2	20.2	20.3	20.3	21.8	16.2	19.6	19.6	19.6	19.6	20.9	15.9	18.9	18.9	18.9	18.9	20.0	15.6
	32	22.0	22.0	22.1	22.1	22.7	20.5	21.4	21.4	21.4	21.4	21.9	20.2	20.7	20.7	20.7	20.7	21.1	19.9	20.0	20.0	20.0	20.0	20.2	19.6
5692	24	19.0	19.0	20.7	14.2	22.5	8.7	18.4	18.4	19.9	13.7	21.7	8.4	17.7	17.7	19.1	13.4	20.7	8.1	17.0	17.0	18.3	13.0	19.8	7.8
	27	20.2	20.2	20.8	18.3	22.7	13.2	19.5	19.5	20.0	18.0	21.9	12.9	18.9	18.9	19.3	17.7	21.1	12.6	18.2	18.2	18.4	17.4	20.1	12.3
	29	21.3	21.3	21.4	21.4	22.8	17.3	20.7	20.7	20.7	20.7	22.0	17.0	20.0	20.0	20.0	20.0	21.1	16.7	19.3	19.3	19.3	19.3	20.2	16.4
	32	22.6	22.6	22.6	22.6	23.0	21.7	21.9	21.9	21.9	21.9	22.2	21.4	21.2	21.2	21.2	21.2	21.4	21.1	20.4	20.4	20.4	20.4	20.4	20.4
6244	24	19.3	19.3	20.8	14.5	22.7	8.8	18.7	18.7	20.1	14.2	21.8	8.6	18.0	18.0	19.3	13.9	20.8	8.3	17.3	17.3	18.4	13.5	19.8	8.0
	27	20.5	20.5	21.0	19.2	22.9	13.7	19.9	19.9	20.2	18.9	22.1	13.4	19.2	19.2	19.5	18.6	21.2	13.1	18.5	18.5	18.6	18.3	20.3	12.8
	29	21.8	21.8	21.8	21.8	23.0	18.1	21.1	21.1	21.1	21.1	22.2	17.8	20.4	20.4	20.4	20.4	21.3	17.5	19.6	19.6	19.7	19.7	20.4	17.2
	32	23.0	23.0	23.0	23.0	23.2	22.8	22.3	22.3	22.3	22.3	22.4	22.4	21.6	21.6	21.6	21.6	21.6	21.6	20.8	20.8	20.8	20.8	20.8	20.8
6796	24	19.7	19.7	21.0	15.1	22.8	9.0	19.0	19.0	20.2	14.7	21.9	8.7	18.3	18.3	19.4	14.4	20.9	8.4	17.6	17.6	18.5	14.0	19.9	8.1
	27	20.9	20.9	21.2	20.1	23.1	14.2	20.2	20.2	20.4	19.8	22.2	13.9	19.5	19.5	19.7	19.5	21.3	13.6	18.8	18.8	18.8	18.8	20.4	13.3
	29	22.1	22.1	22.2	22.2	23.2	18.9	21.5	21.5	21.5	21.5	22.3	18.6	20.7	20.7	20.7	20.7	21.5	18.3	19.9	19.9	20.0	20.0	20.5	17.9
	32	23.4	23.4	23.4	23.4	23.4	23.4	22.7	22.7	22.7	22.7	22.7	22.7	21.9	21.9	22.0	22.0	22.0	22.0	21.1	21.1	21.1	21.1	21.2	21.2

Equal TGC and SHC values constitute dry coil conditions. Total Gross Cooling (TGC) shown to the left is not applicable. In this case the Sensible Heat Capacity (SHC) is the total capacity.

All capacities shown are gross and have not considered indoor fan heat.
 To obtain net cooling capacities subtract indoor fan heat.
 TGC = Total Gross Cooling Capacity
 SHC = Sensible Heat Capacity



Performance Data System

Table PD-9 — Gross Cooling Capacities (MBh) TTA125B Condensing Unit with TWE100B Air Handler (I-P)

CFM		Ambient Temperature (°F)																									
		85						95						105						115							
		Enter. Dry Bulb (°F)		Entering Wet Bulb (°F)												Enter. Dry Bulb (°F)		Entering Wet Bulb (°F)									
Airflow		61	67	73		61	67	73		61	67	73		61	67	73		61	67	73		61	67	73			
	75	109.9	81.1	121.9	71.0	135.2	49.8	106.3	79.2	117.8	69.3	130.6	48.0	102.0	76.9	113.3	67.5	125.5	46.3	97.6	74.6	108.5	65.5	120.2	44.3		
	80	110.2	92.5	122.2	78.4	135.2	63.2	106.5	90.6	118.1	76.5	130.6	61.3	102.5	88.4	113.7	74.5	125.6	59.3	98.1	86.1	108.9	72.3	120.2	57.1		
	85	110.6	104.2	122.5	90.4	135.4	75.2	107.1	102.3	118.2	88.3	130.8	73.3	103.3	100.2	113.8	86.1	125.9	71.3	99.2	98.0	109.1	83.8	120.6	69.2		
	90	113.5	113.5	122.7	101.8	135.7	87.3	110.5	110.5	118.6	99.8	131.1	85.4	107.3	107.3	114.2	97.7	126.2	83.3	103.6	103.6	109.5	95.4	120.9	81.2		
3350	75	112.6	84.5	124.7	68.5	138.0	50.8	108.5	82.3	120.4	66.6	133.2	49.1	104.3	80.0	115.7	64.5	127.9	47.2	99.8	77.7	110.7	62.3	122.3	45.3		
	80	112.8	96.8	125.0	81.5	138.0	65.0	109.0	94.7	120.7	79.6	133.2	63.0	104.8	92.5	116.1	77.5	128.0	61.0	100.3	90.1	111.1	75.3	122.4	58.8		
	85	113.6	109.5	125.1	94.2	138.3	78.0	110.0	107.6	120.8	92.1	133.5	76.1	106.1	105.5	116.3	90.0	128.3	74.1	101.8	101.8	111.4	87.6	122.8	71.9		
	90	117.6	117.6	125.5	106.7	138.6	91.1	114.5	114.5	121.3	104.6	133.8	89.1	111.0	111.0	116.7	102.5	128.7	87.1	107.2	107.2	111.8	100.1	123.2	84.9		
3675	75	114.6	87.3	127.0	70.4	140.3	51.8	110.7	85.3	122.5	68.5	135.3	50.0	106.4	83.0	117.7	66.4	129.9	48.2	101.6	80.6	112.5	64.1	124.1	46.2		
	80	115.1	100.8	127.3	84.5	140.3	66.6	111.2	98.7	122.9	82.5	135.4	64.7	106.9	96.4	118.1	80.4	130.0	62.6	102.1	94.0	113.0	78.1	124.3	60.4		
	85	116.3	114.6	127.5	97.9	140.6	80.7	112.2	112.2	123.1	95.8	135.7	78.7	108.7	108.7	118.4	93.6	130.4	76.6	104.8	104.8	113.3	91.2	124.7	74.5		
	90	121.3	121.3	127.9	111.3	141.0	94.7	117.9	117.9	123.5	109.2	136.1	92.7	114.3	114.3	118.8	107.0	130.5	90.3	110.4	110.4	113.8	104.7	124.9	87.9		
4000	75	116.6	90.2	129.0	72.3	142.3	52.7	112.5	88.1	124.4	70.3	137.1	51.0	108.1	85.8	119.4	68.1	131.5	49.1	103.2	83.3	114.1	65.9	125.6	46.9		
	80	117.1	104.5	129.4	87.2	142.3	68.2	113.0	102.4	124.8	85.2	137.3	66.2	108.6	100.2	119.6	82.7	131.8	64.1	103.9	97.7	114.4	80.3	125.9	61.9		
	85	118.5	118.5	129.6	101.4	142.7	83.2	115.1	115.1	125.1	99.3	137.7	81.2	111.5	111.5	120.2	97.0	132.2	79.1	107.5	107.5	114.9	94.6	126.4	76.9		
	90	124.5	124.5	130.0	115.8	143.1	98.1	121.1	121.1	125.5	113.7	137.8	95.7	117.3	117.3	120.7	111.4	132.4	93.5	113.2	113.2	115.6	109.1	126.6	91.1		

Equal TGC and SHC values constitute dry coil conditions. Total Gross Cooling (TGC) shown to the left is not applicable. In this case the Sensible Heat Capacity (SHC) is the total capacity.

All capacities shown are gross and have not considered indoor fan heat.
 To obtain net cooling capacities subtract indoor fan heat.
 TGC = Total Gross Cooling Capacity
 SHC = Sensible Heat Capacity

Table PD-9 — Gross Cooling Capacities (kW) TTA125B Condensing Unit with TWE100B Air Handler (SI)

m³/h		Ambient Temperature (°C)																							
		29.4				35.0				40.6				46.1											
		Enter. Dry Bulb (°C)		Entering Wet Bulb (°C)										Enter. Dry Bulb (°C)		Entering Wet Bulb (°C)									
Airflow		16.1	19.4	22.8		16.1	19.4	22.8		16.1	19.4	22.8		16.1	19.4	22.8		16.1	19.4	22.8		16.1	19.4	22.8	
5139	24	32.2	23.7	35.7	20.8	39.6	14.6	31.1	23.2	34.5	20.3	38.2	14.1	29.9	22.5	33.2	19.8	36.8	13.6	28.6	21.8	31.8	19.2	35.2	13.0
	27	32.3	27.1	35.8	23.0	39.6	18.5	31.2	26.5	34.6	22.4	38.2	17.9	30.0	25.9	33.3	21.8	36.8	17.4	28.7	25.2	31.9	21.2	35.2	16.7
	29	32.4	30.5	35.9	26.5	39.6	22.0	31.4	29.9	34.6	25.8	38.3	21.5	30.2	29.3	33.3	25.2	36.9	20.9	29.0	28.7	31.9	24.6	35.3	20.3
	32	33.2	33.2	35.9	29.8	39.7	25.5	32.4	32.4	34.7	29.2	38.4	25.0	31.4	31.4	33.5	28.6	36.9	24.4	30.3	30.3	32.1	27.9	35.4	23.8
5692	24	33.0	24.7	36.5	20.1	40.4	14.9	31.8	24.1	35.2	19.5	39.0	14.4	30.5	23.4	33.9	18.9	37.5	13.8	29.2	22.7	32.4	18.2	35.8	13.3
	27	33.0	28.3	36.6	23.9	40.4	19.0	31.9	27.7	35.3	23.3	39.0	18.5	30.7	27.1	34.0	22.7	37.5	17.9	29.4	26.4	32.5	22.1	35.9	17.2
	29	33.3	32.1	36.6	27.6	40.5	22.8	32.2	31.5	35.4	27.0	39.1	22.3	31.1	30.9	34.0	26.3	37.6	21.7	29.8	29.8	32.6	25.7	36.0	21.1
	32	34.4	34.4	36.8	31.2	40.6	26.7	33.5	33.5	35.5	30.6	39.2	26.1	32.5	32.5	34.2	30.0	37.7	25.5	31.4	31.4	32.7	29.3	36.1	24.9
6244	24	33.6	25.6	37.2	20.6	41.1	15.2	32.4	25.0	35.9	20.0	39.6	14.7	31.1	24.3	34.5	19.4	38.0	14.1	29.8	23.6	32.9	18.8	36.3	13.5
	27	33.7	29.5	37.3	24.7	41.1	19.5	32.5	28.9	36.0	24.1	39.6	18.9	31.3	28.2	34.6	23.5	38.1	18.3	29.9	27.5	33.1	22.9	36.4	17.7
	29	34.0	33.6	37.3	28.7	41.2	23.6	32.8	32.8	36.0	28.0	39.7	23.0	31.8	31.8	34.7	27.4	38.2	22.4	30.7	30.7	33.2	26.7	36.5	21.8
	32	35.5	35.5	37.5	32.6	41.3	27.7	34.5	34.5	36.2	32.0	39.8	27.1	33.5	33.5	34.8	31.3	38.2	26.4	32.3	32.3	33.3	30.7	36.6	25.7
6796	24	34.1	26.4	37.8	21.2	41.7	15.4	32.9	25.8	36.4	20.6	40.2	14.9	31.7	25.1	35.0	19.9	38.5	14.4	30.2	24.4	33.4	19.3	36.8	13.7
	27	34.3	30.6	37.9	25.5	41.7	20.0	33.1	30.0	36.5	25.0	40.2	19.4	31.8	29.3	35.0	24.2	38.6	18.8	30.4	28.6	33.5	23.5	36.9	18.1
	29	34.7	34.7	38.0	29.7	41.8	24.3	33.7	33.7	36.6	29.1	40.3	23.8	32.6	32.6	35.2	28.4	38.7	23.2	31.5	31.5	33.7	27.7	37.0	22.5
	32	36.5	36.5	38.1	33.9	41.9	28.7	35.4	35.4	36.7	33.3	40.3	28.0	34.3	34.3	35.3	32.6	38.8	27.4	33.1	33.1	33.9	31.9	37.1	26.7

Equal TGC and SHC values constitute dry coil conditions. Total Gross Cooling (TGC) shown to the left is not applicable. In this case the Sensible Heat Capacity (SHC) is the total capacity.

All capacities shown are gross and have not considered indoor fan heat.
 To obtain net cooling capacities subtract indoor fan heat.
 TGC = Total Gross Cooling Capacity
 SHC = Sensible Heat Capacity



Performance Data

System

Table PD-10 — Gross Cooling Capacities (MBh) TTA125B Condensing Unit with TWE155B Air Handler (I-P)

CFM		Ambient Temperature (°F)																							
		85						95						105						115					
		Enter. Dry Bulb (°F)		Entering Wet Bulb (°F)																					
		61		67		73		61		67		73		61		67		73		61		67		73	
Airflow		TGC	SHC	TGC	SHC	TGC	SHC	TGC	SHC	TGC	SHC	TGC	SHC	TGC	SHC	TGC	SHC	TGC	SHC	TGC	SHC	TGC	SHC	TGC	SHC
3750	75	124.0	98.6	136.6	82.4	149.8	55.6	119.5	96.3	131.6	80.4	144.1	53.6	114.6	93.8	126.1	78.2	137.9	51.5	109.3	91.2	120.3	75.9	131.3	49.3
	80	124.7	115.3	136.9	94.8	150.4	73.4	120.2	113.0	131.9	92.5	144.8	71.3	115.5	110.6	126.5	90.1	138.9	69.1	110.5	108.1	120.8	87.5	132.5	66.8
	85	128.0	128.0	137.5	111.4	151.0	90.7	124.2	124.2	132.5	109.1	145.4	88.7	120.1	120.1	127.1	106.7	139.5	86.5	115.6	115.6	121.4	104.1	132.8	83.5
	90	134.5	134.5	138.2	128.2	151.2	107.1	130.6	130.6	133.3	125.9	145.7	104.9	126.3	126.3	128.2	123.6	139.9	102.5	121.7	121.7	122.8	121.1	133.6	100.0
4200	75	126.6	103.5	139.2	81.3	152.2	56.6	121.9	101.2	134.0	79.1	146.3	54.6	116.9	98.7	128.4	76.8	140.0	52.4	111.4	96.0	121.9	73.8	133.2	50.2
	80	127.6	122.0	139.6	99.3	153.0	76.1	123.1	119.7	134.4	97.0	147.3	74.0	118.3	117.3	128.8	94.5	141.2	71.8	113.1	113.1	122.9	91.8	134.6	69.4
	85	132.5	132.5	140.2	117.6	153.7	95.2	128.5	128.5	135.0	115.3	147.6	92.4	124.1	124.1	129.5	112.8	141.5	90.0	119.4	119.4	123.6	110.2	135.0	87.4
	90	139.3	139.3	141.3	136.2	154.0	112.9	135.1	135.1	136.4	133.9	148.3	110.6	130.6	130.6	130.7	130.7	142.2	108.2	125.8	125.8	125.9	125.9	135.8	105.6
4650	75	128.8	108.2	141.4	84.2	154.2	57.7	123.9	105.8	136.0	82.1	148.1	55.6	118.7	103.3	129.7	79.0	141.6	53.4	113.1	100.5	123.6	76.3	134.6	51.0
	80	130.2	128.5	141.8	103.6	155.2	78.7	125.3	125.3	136.5	101.2	149.3	76.5	120.9	120.9	130.8	98.7	143.0	74.3	116.1	116.1	124.7	96.0	136.2	71.9
	85	136.4	136.4	142.4	123.5	155.6	98.5	132.2	132.2	137.2	121.2	149.7	96.2	127.5	127.5	131.5	118.6	143.5	93.7	122.6	122.6	125.6	116.0	136.9	91.1
	90	143.4	143.4	144.2	144.0	156.3	118.4	139.0	139.0	139.2	139.2	150.4	116.1	134.3	134.3	134.4	134.4	144.2	113.6	129.2	129.2	129.3	129.3	137.6	111.0
5100	75	130.6	112.7	142.7	86.5	155.8	58.6	125.6	110.3	137.3	84.1	149.6	56.4	120.3	107.7	131.3	81.4	142.9	54.1	114.7	104.9	125.1	78.6	135.8	51.7
	80	132.5	132.5	143.7	107.7	157.0	81.1	128.3	128.3	138.3	105.3	151.0	79.0	123.7	123.7	132.4	102.7	144.5	76.7	118.8	118.8	126.2	100.0	137.6	74.4
	85	139.7	139.7	144.4	129.2	157.5	102.2	135.4	135.4	139.1	126.9	151.5	99.9	130.6	130.6	133.3	124.3	145.2	97.3	125.5	125.5	127.3	121.7	138.4	94.7
	90	147.0	147.0	147.2	147.2	158.2	123.7	142.5	142.5	142.6	142.6	152.2	121.3	137.6	137.6	137.7	137.7	145.9	118.8	132.3	132.3	132.4	132.4	139.1	116.2

Equal TGC and SHC values constitute dry coil conditions. Total Gross Cooling (TGC) shown to the left is not applicable. In this case the Sensible Heat Capacity (SHC) is the total capacity.

All capacities shown are gross and have not considered indoor fan heat.
 To obtain net cooling capacities subtract indoor fan heat.
 TGC = Total Gross Cooling Capacity
 SHC = Sensible Heat Capacity

Table PD-10 — Gross Cooling Capacities (kW) TTA125B Condensing Unit with TWE155B Air Handler (SI)

m³/h		Ambient Temperature (°C)																							
		29.4				35.0				40.6				46.1											
		Enter. Dry Bulb (°C)		Entering Wet Bulb (°C)																					
		16.1		19.4		22.8		16.1		19.4		22.8		16.1		19.4		22.8							
Airflow		TGC	SHC	TGC	SHC	TGC	SHC	TGC	SHC	TGC	SHC	TGC	SHC	TGC	SHC	TGC	SHC	TGC	SHC						
6371	24	36.3	28.9	40.0	24.1	43.9	16.3	35.0	28.2	38.5	23.5	42.2	15.7	33.6	27.5	36.9	22.9	40.4	15.1	32.0	26.7	35.2	22.2	38.5	14.4
	27	36.5	33.8	40.1	27.8	44.0	21.5	35.2	33.1	38.6	27.1	42.4	20.9	33.8	32.4	37.0	26.4	40.7	20.2	32.4	31.6	35.4	25.6	38.8	19.6
	29	37.5	37.5	40.3	32.6	44.2	26.6	36.4	36.4	38.8	32.0	42.6	26.0	35.2	35.2	37.2	31.2	40.9	25.3	33.8	33.8	35.5	30.5	38.9	24.4
	32	39.4	39.4	40.5	37.5	44.3	31.4	38.2	38.2	39.0	36.9	42.7	30.7	37.0	37.0	37.5	36.2	40.9	30.0	35.6	35.6	35.9	35.5	39.1	29.3
7136	24	37.1	30.3	40.8	23.8	44.6	16.6	35.7	29.6	39.2	23.2	42.8	16.0	34.2	28.9	37.6	22.5	41.0	15.4	32.6	28.1	35.7	21.6	39.0	14.7
	27	37.4	35.7	40.9	29.1	44.8	22.3	36.0	35.1	39.4	28.4	43.1	21.7	34.6	34.3	37.7	27.7	41.3	21.0	33.1	33.1	36.0	26.9	39.4	20.3
	29	38.8	38.8	41.0	34.4	45.0	27.9	37.6	37.6	39.5	33.7	43.2	27.1	36.3	36.3	37.9	33.0	41.4	26.3	35.0	35.0	36.2	32.3	39.5	25.6
	32	40.8	40.8	41.4	39.9	45.1	33.1	39.6	39.6	39.9	39.2	43.4	32.4	38.2	38.2	38.3	38.3	41.7	31.7	36.8	36.8	36.9	36.9	39.8	30.9
7900	24	37.7	31.7	41.4	24.7	45.1	16.9	36.3	31.0	39.8	24.0	43.4	16.3	34.8	30.2	38.0	23.1	41.5	15.6	33.1	29.4	36.2	22.3	39.4	14.9
	27	38.1	37.6	41.5	30.3	45.4	23.0	36.7	36.7	40.0	29.6	43.7	22.4	35.4	35.4	38.3	28.9	41.9	21.8	34.0	34.0	36.5	28.1	39.9	21.1
	29	39.9	39.9	41.7	36.2	45.6	28.9	38.7	38.7	40.2	35.5	43.8	28.2	37.3	37.3	38.5	34.7	42.0	27.4	35.9	35.9	36.8	34.0	40.1	26.7
	32	42.0	42.0	42.2	42.2	45.8	34.7	40.7	40.7	40.7	44.1	34.0	39.3	39.3	39.4	39.4	42.2	33.3	37.8	37.8	37.9	37.9	40.3	32.5	
8665	24	38.2	33.0	41.8	25.3	45.6	17.2	36.8	32.3	40.2	24.6	43.8	16.5	35.2	31.5	38.5	23.8	41.8	15.8	33.6	30.7	36.6	23.0	39.8	15.1
	27	38.8	38.8	42.1	31.5	46.0	23.8	37.6	37.6	40.5	30.8	44.2	23.1	36.2	36.2	38.8	30.1	42.3	22.5	34.8	34.8	37.0	29.3	40.3	21.8
	29	40.9	40.9	42.3	37.8	46.1	29.9	39.6	39.6	40.7	37.1	44.4	29.2	38.2	38.2	39.0	36.4	42.5	28.5	36.7	36.7	37.3	35.6	40.5	27.7
	32	43.0	43.0	43.1	43.1	46.3	36.2	41.7	41.7	41.8	41.8	44.6	35.5	40.3	40.3	40.3	42.7	34.8	38.7	38.7	38.8	38.8	40.7	34.0	

Equal TGC and SHC values constitute dry coil conditions. Total Gross Cooling (TGC) shown to the left is not applicable. In this case the Sensible Heat Capacity (SHC) is the total capacity.

All capacities shown are gross and have not considered indoor fan heat.
 To obtain net cooling capacities subtract indoor fan heat.
 TGC = Total Gross Cooling Capacity
 SHC = Sensible Heat Capacity



Performance Data System

Table PD-11 — Gross Cooling Capacities (MBh) TTA155B Condensing Unit with TWE155B Air Handler (I-P)

CFM		Ambient Temperature (°F)																							
		85						95						105						115					
		Enter. Dry Bulb		Entering Wet Bulb (°F)																					
Airflow	(°F)	TGC	SHC	TGC	SHC	TGC	SHC	TGC	SHC	TGC	SHC	TGC	SHC	TGC	SHC	TGC	SHC	TGC	SHC	TGC	SHC	TGC	SHC	TGC	SHC
4500	75	153.4	120.3	169.3	101.1	185.9	68.9	148.2	117.6	163.3	98.6	178.9	66.4	142.0	114.4	156.3	95.8	170.9	63.7	134.9	110.8	148.4	92.6	162.0	60.6
	80	154.3	140.1	169.6	116.0	186.6	90.3	149.1	137.4	163.7	113.2	179.8	87.7	143.0	134.3	156.7	110.0	172.0	84.8	136.2	130.8	149.0	106.4	163.5	81.7
	85	157.3	157.3	170.5	135.7	187.4	111.0	152.9	152.9	164.5	132.9	180.6	108.4	147.7	147.7	157.6	129.7	172.9	105.5	141.7	141.7	149.9	126.2	163.9	101.7
	90	165.4	165.4	171.3	155.6	187.6	130.6	160.8	160.8	165.5	152.8	180.9	127.9	155.3	155.3	158.8	149.7	173.3	124.7	149.2	149.2	151.4	146.3	165.0	121.3
5000	75	156.6	125.7	172.5	99.4	188.8	70.0	151.1	122.9	166.2	96.8	181.5	67.5	144.6	119.7	158.9	93.8	173.3	64.7	137.3	116.0	150.8	90.5	164.2	61.6
	80	157.7	147.5	172.9	120.9	189.8	93.3	152.4	144.8	166.7	118.1	182.7	90.7	146.1	141.6	159.5	114.8	174.7	87.7	139.2	138.0	151.6	111.2	166.0	84.6
	85	162.6	162.6	173.8	142.5	190.6	115.9	157.9	157.9	167.6	139.6	183.6	113.3	152.4	152.4	160.4	136.4	175.2	109.4	146.1	146.1	152.5	132.8	166.5	105.9
	90	171.0	171.0	175.0	164.3	191.1	137.0	166.1	166.1	169.0	161.6	184.1	134.1	160.3	160.3	162.2	158.4	176.2	130.9	153.9	153.9	154.0	154.0	167.6	127.4
5500	75	159.3	130.9	175.1	102.7	191.1	71.3	153.6	128.1	168.6	100.0	183.6	68.7	146.9	124.7	161.1	97.0	175.2	65.9	139.4	120.9	152.2	92.7	165.9	62.6
	80	160.8	154.6	175.7	125.6	192.4	96.1	155.3	151.8	169.2	122.7	185.1	93.5	149.0	148.6	161.9	119.4	176.9	90.5	141.9	141.9	153.7	115.7	167.9	87.3
	85	167.2	167.2	176.5	148.9	192.8	119.7	162.3	162.3	170.1	146.0	185.6	116.8	156.5	156.5	162.8	142.7	177.5	113.6	149.9	149.9	154.7	139.1	168.7	110.0
	90	175.9	175.9	178.3	172.8	194.0	143.0	170.7	170.7	172.2	170.0	186.7	140.1	164.7	164.7	164.8	164.8	178.6	136.8	157.9	157.9	158.1	158.1	169.8	133.3
6000	75	161.5	135.9	177.3	105.9	193.1	72.5	155.6	132.9	170.6	103.2	185.5	69.7	148.8	129.5	162.4	99.0	176.8	66.7	141.2	125.7	154.0	95.3	167.3	63.5
	80	163.6	161.5	178.0	130.1	194.7	98.8	157.4	157.4	171.4	127.2	187.2	96.1	151.6	151.6	163.8	123.8	178.8	93.2	145.0	145.0	155.5	120.0	169.6	90.0
	85	171.3	171.3	178.9	155.2	195.3	123.8	166.1	166.1	172.4	152.3	187.8	120.8	160.0	160.0	164.9	148.9	179.6	117.5	153.2	153.2	156.8	145.3	170.6	113.9
	90	180.2	180.2	181.4	181.0	196.5	148.8	174.7	174.7	174.9	174.9	188.8	145.8	168.5	168.5	168.6	168.6	180.7	142.5	161.5	161.5	161.6	161.6	171.7	139.0

Equal TGC and SHC values constitute dry coil conditions. Total Gross Cooling (TGC) shown to the left is not applicable. In this case the Sensible Heat Capacity (SHC) is the total capacity.

All capacities shown are gross and have not considered indoor fan heat.
 To obtain net cooling capacities subtract indoor fan heat.
 TGC = Total Gross Cooling Capacity
 SHC = Sensible Heat Capacity

Table PD-11 — Gross Cooling Capacities (kW) TTA155B Condensing Unit with TWE155B Air Handler (SI)

m³/h		Ambient Temperature (°C)																							
		29.4						35.0						40.6						46.1					
		Enter. Dry Bulb		Entering Wet Bulb (°C)																					
Airflow	(°C)	TGC	SHC	TGC	SHC	TGC	SHC	TGC	SHC	TGC	SHC	TGC	SHC	TGC	SHC	TGC	SHC	TGC	SHC	TGC	SHC	TGC	SHC	TGC	SHC
7646	24	44.9	35.2	49.6	29.6	54.4	20.2	43.4	34.4	47.8	28.9	52.4	19.4	41.6	33.5	45.8	28.0	50.0	18.6	39.5	32.4	43.5	27.1	47.4	17.8
	27	45.2	41.0	49.7	34.0	54.6	26.4	43.7	40.2	47.9	33.1	52.6	25.7	41.9	39.3	45.9	32.2	50.4	24.8	39.9	38.3	43.6	31.2	47.9	23.9
	29	46.1	46.1	49.9	39.7	54.9	32.5	44.8	44.8	48.2	38.9	52.9	31.7	43.2	43.2	46.2	38.0	50.6	30.9	41.5	41.5	43.9	36.9	48.0	29.8
	32	48.4	48.4	50.2	45.6	54.9	38.3	47.1	47.1	48.5	44.8	53.0	37.4	45.5	45.5	46.5	43.8	50.8	36.5	43.7	43.7	44.3	42.8	48.3	35.5
8495	24	45.8	36.8	50.5	29.1	55.3	20.5	44.2	36.0	48.7	28.3	53.1	19.8	42.4	35.0	46.5	27.5	50.7	18.9	40.2	34.0	44.2	26.5	48.1	18.0
	27	46.2	43.2	50.6	35.4	55.6	27.3	44.6	42.4	48.8	34.6	53.5	26.5	42.8	41.5	46.7	33.6	51.2	25.7	40.8	40.4	44.4	32.6	48.6	24.8
	29	47.6	47.6	50.9	41.7	55.8	33.9	46.2	46.2	49.1	40.9	53.8	33.2	44.6	44.6	47.0	39.9	51.3	32.0	42.8	42.8	44.6	38.9	48.8	31.0
	32	50.1	50.1	51.2	48.1	56.0	40.1	48.6	48.6	49.5	47.3	53.9	39.3	46.9	46.9	47.5	46.4	51.6	38.3	45.1	45.1	45.1	45.1	49.1	37.3
9345	24	46.6	38.3	51.3	30.1	56.0	20.9	45.0	37.5	49.4	29.3	53.8	20.1	43.0	36.5	47.2	28.4	51.3	19.3	40.8	35.4	44.6	27.1	48.6	18.3
	27	47.1	45.3	51.4	36.8	56.3	28.1	45.5	44.5	49.6	35.9	54.2	27.4	43.6	43.5	47.4	35.0	51.8	26.5	41.6	41.6	45.0	33.9	49.2	25.6
	29	49.0	49.0	51.7	43.6	56.5	35.1	47.5	47.5	49.8	42.8	54.3	34.2	45.8	45.8	47.7	41.8	52.0	33.3	43.9	43.9	45.3	40.7	49.4	32.2
	32	51.5	51.5	52.2	50.6	56.8	41.9	50.0	50.0	50.4	49.8	54.7	41.0	48.2	48.2	48.3	48.3	52.3	40.1	46.2	46.2	46.3	46.3	49.7	39.0
10194	24	47.3	39.8	51.9	31.0	56.5	21.2	45.6	38.9	50.0	30.2	54.3	20.4	43.6	37.9	47.5	29.0	51.8	19.5	41.3	36.8	45.1	27.9	49.0	18.6
	27	47.9	47.3	52.1	38.1	57.0	28.9	46.1	46.1	50.2	37.2	54.8	28.2	44.4	44.4	48.0	36.2	52.3	27.3	42.5	42.5	45.5	35.1	49.7	26.3
	29	50.2	50.2	52.4	45.4	57.2	36.3	48.6	48.6	50.5	44.6	55.0	35.4	46.9	46.9	48.3	43.6	52.6	34.4	44.9	44.9	45.9	42.5	50.0	33.4
	32	52.8	52.8	53.1	53.0	57.5	43.6	51.2	51.2	51.2	51.2	55.3	42.7	49.3	49.3	49.4	49.4	52.9	41.7	47.3	47.3	47.3	47.3	50.3	40.7

Equal TGC and SHC values constitute dry coil conditions. Total Gross Cooling (TGC) shown to the left is not applicable. In this case the Sensible Heat Capacity (SHC) is the total capacity.

All capacities shown are gross and have not considered indoor fan heat.
 To obtain net cooling capacities subtract indoor fan heat.
 TGC = Total Gross Cooling Capacity
 SHC = Sensible Heat Capacity



Performance Data

System

Table PD-12— Gross Cooling Capacities (MBh) TTA155B Condensing Unit with TWE200B Air Handler (I-P)

CFM		Ambient Temperature (°F)																							
		85						95						105						115					
		Enter. Dry Bulb (°F)		Entering Wet Bulb (°F)																					
		61	67	73	61	67	73	61	67	73	61	67	73	61	67	73	61	67	73						
		TGC	SHC	TGC	SHC	TGC	SHC	TGC	SHC	TGC	SHC	TGC	SHC	TGC	SHC	TGC	SHC	TGC	SHC	TGC	SHC	TGC	SHC		
4500	75	157.9	124.4	174.3	103.2	191.0	70.7	152.4	121.5	168.0	100.6	183.7	68.2	145.9	118.2	160.7	97.7	175.3	65.3	138.5	114.5	152.5	94.4	166.2	62.2
	80	158.8	145.1	174.6	119.9	192.0	93.1	153.4	142.3	168.4	117.0	184.9	90.5	147.0	139.1	161.1	113.7	176.9	87.5	139.9	135.4	153.1	110.0	168.1	84.2
	85	162.4	162.4	175.4	140.4	192.8	114.7	157.7	157.7	169.2	137.6	185.8	112.0	152.2	152.2	162.0	134.3	177.8	109.1	146.0	146.0	154.0	130.6	168.5	105.0
	90	170.7	170.7	176.3	161.3	193.0	135.2	165.8	165.8	170.2	158.4	186.1	132.3	160.1	160.1	163.3	155.2	178.2	129.1	153.7	153.7	155.6	151.7	169.6	125.6
5000	75	161.2	130.3	177.6	102.7	193.9	71.9	155.4	127.3	171.0	100.0	186.4	69.3	148.7	123.9	163.4	96.9	177.8	66.4	141.0	120.1	155.0	93.5	168.4	63.2
	80	162.4	153.1	178.0	125.2	195.2	96.3	156.8	150.2	171.5	122.2	187.9	93.6	150.3	146.9	164.0	118.8	179.7	90.6	142.6	142.6	155.8	115.1	170.6	87.4
	85	167.9	167.9	178.8	147.8	196.1	119.9	163.0	163.0	172.4	144.8	188.9	117.3	157.2	157.2	164.9	141.5	180.1	113.2	150.6	150.6	156.7	137.8	171.3	109.6
	90	176.6	176.6	180.2	170.7	196.5	141.9	171.4	171.4	173.9	167.9	189.3	139.0	165.4	165.4	166.9	164.6	181.2	135.8	158.7	158.7	158.9	158.9	172.4	132.2
5500	75	164.0	135.9	180.2	106.3	196.3	73.2	158.0	132.9	173.5	103.5	188.6	70.6	151.0	129.4	165.7	100.4	179.8	67.6	143.2	125.5	156.3	95.6	170.1	64.4
	80	165.6	160.8	180.8	130.2	197.9	99.4	159.9	157.9	174.1	127.2	190.4	96.7	153.0	153.0	166.5	123.8	182.0	93.6	146.3	146.3	158.0	120.0	172.7	90.4
	85	172.8	172.8	181.7	154.8	198.4	124.0	167.6	167.6	175.0	151.8	190.9	121.0	161.5	161.5	167.5	148.4	182.6	117.6	154.7	154.7	159.1	144.7	173.6	114.0
	90	181.7	181.7	183.6	179.9	199.4	148.4	176.3	176.3	177.4	177.0	192.0	145.5	170.0	170.0	170.2	170.2	183.7	142.2	163.0	163.0	163.2	163.2	174.7	138.6
6000	75	166.3	141.2	182.5	109.7	198.4	74.4	160.2	138.2	174.9	105.9	190.4	71.7	153.0	134.6	167.0	102.3	181.4	68.6	145.1	130.7	158.8	100.2	171.5	65.3
	80	168.7	168.3	183.2	135.1	200.2	102.3	162.7	162.7	176.4	132.0	192.5	99.6	156.5	156.5	168.5	128.5	183.9	96.5	149.6	149.6	159.9	124.7	174.5	93.3
	85	177.1	177.1	184.2	161.6	200.8	128.4	171.6	171.6	177.4	158.6	193.2	125.3	165.3	165.3	169.7	155.1	184.8	121.9	158.2	158.2	161.3	151.4	175.5	118.2
	90	186.3	186.3	186.5	186.5	201.8	154.7	180.6	180.6	180.8	180.8	194.3	151.7	174.1	174.1	174.3	174.3	185.9	148.4	166.8	166.8	167.0	167.0	176.7	144.8

Equal TGC and SHC values constitute dry coil conditions. Total Gross Cooling (TGC) shown to the left is not applicable. In this case the Sensible Heat Capacity (SHC) is the total capacity.

All capacities shown are gross and have not considered indoor fan heat.
 To obtain net cooling capacities subtract indoor fan heat.
 TGC = Total Gross Cooling Capacity
 SHC = Sensible Heat Capacity

Table PD-12 — Gross Cooling Capacities (kW) TTA155B Condensing Unit with TWE200B Air Handler (SI)

m³/h		Ambient Temperature (°C)																							
		29.4						35.0						40.6						46.1					
		Enter. Dry Bulb (°C)		Entering Wet Bulb (°C)																					
		16.1	19.4	22.8	16.1	19.4	22.8	16.1	19.4	22.8	16.1	19.4	22.8	16.1	19.4	22.8									
		TGC	SHC	TGC	SHC	TGC	SHC	TGC	SHC	TGC	SHC	TGC	SHC	TGC	SHC	TGC	SHC	TGC	SHC	TGC	SHC	TGC	SHC		
7646	23.9	46.2	36.4	51.0	30.2	55.9	20.7	44.6	35.6	49.2	29.5	53.8	20.0	42.7	34.6	47.0	28.6	51.3	19.1	40.5	33.5	44.6	27.6	48.7	18.2
	26.7	46.5	42.5	51.1	35.1	56.2	27.3	44.9	41.7	49.3	34.3	54.1	26.5	43.0	40.7	47.2	33.3	51.8	25.6	41.0	39.7	44.8	32.2	49.2	24.7
	29.4	47.5	47.5	51.4	41.1	56.4	33.6	46.2	46.2	49.5	40.3	54.4	32.8	44.6	44.6	47.4	39.3	52.1	31.9	42.7	42.7	45.1	38.2	49.3	30.7
	32.2	50.0	50.0	51.6	47.2	56.5	39.6	48.6	48.6	49.8	46.4	54.5	38.7	46.9	46.9	47.8	45.5	52.2	37.8	45.0	45.0	45.6	44.4	49.7	36.8
8495	23.9	47.2	38.1	52.0	30.1	56.8	21.1	45.5	37.3	50.1	29.3	54.6	20.3	43.5	36.3	47.8	28.4	52.1	19.4	41.3	35.2	45.4	27.4	49.3	18.5
	26.7	47.6	44.8	52.1	36.6	57.2	28.2	45.9	44.0	50.2	35.8	55.0	27.4	44.0	43.0	48.0	34.8	52.6	26.5	41.7	41.7	45.6	33.7	50.0	25.6
	29.4	49.2	49.2	52.4	43.3	57.4	35.1	47.7	47.7	50.5	42.4	55.3	34.3	46.0	46.0	48.3	41.4	52.7	33.1	44.1	44.1	45.9	40.3	50.1	32.1
	32.2	51.7	51.7	52.7	50.0	57.5	41.6	50.2	50.2	50.9	49.2	55.4	40.7	48.4	48.4	48.9	48.2	53.1	39.8	46.5	46.5	46.5	46.5	50.5	38.7
9345	23.9	48.0	39.8	52.8	31.1	57.5	21.4	46.3	38.9	50.8	30.3	55.2	20.7	44.2	37.9	48.5	29.4	52.6	19.8	41.9	36.7	45.8	28.0	49.8	18.8
	26.7	48.5	47.1	52.9	38.1	58.0	29.1	46.8	46.2	51.0	37.3	55.8	28.3	44.8	44.8	48.7	36.2	53.3	27.4	42.8	42.8	46.3	35.1	50.6	26.5
	29.4	50.6	50.6	53.2	45.3	58.1	36.3	49.1	49.1	51.3	44.4	55.9	35.4	47.3	47.3	49.0	43.5	53.5	34.4	45.3	45.3	46.6	42.4	50.8	33.4
	32.2	53.2	53.2	53.8	52.7	58.4	43.5	51.6	51.6	51.9	51.8	56.2	42.6	49.8	49.8	49.8	49.8	53.8	41.6	47.7	47.7	47.8	47.8	51.2	40.6
10194	23.9	48.7	41.4	53.4	32.1	58.1	21.8	46.9	40.5	51.2	31.0	55.7	21.0	44.8	39.4	48.9	30.0	53.1	20.1	42.5	38.3	46.5	29.3	50.2	19.1
	26.7	49.4	49.3	53.7	39.6	58.6	30.0	47.6	47.6	51.6	38.7	56.4	29.1	45.8	45.8	49.4	37.6	53.8	28.3	43.8	43.8	46.8	36.5	51.1	27.3
	29.4	51.8	51.8	53.9	47.3	58.8	37.6	50.3	50.3	52.0	46.4	56.6	36.7	48.4	48.4	49.7	45.4	54.1	35.7	46.3	46.3	47.2	44.3	51.4	34.6
	32.2	54.5	54.5	54.6	54.6	59.1	45.3	52.9	52.9	52.9	52.9	56.9	44.4	51.0	51.0	51.0	51.0	54.4	43.5	48.8	48.8	48.9	48.9	51.7	42.4

Equal TGC and SHC values constitute dry coil conditions. Total Gross Cooling (TGC) shown to the left is not applicable. In this case the Sensible Heat Capacity (SHC) is the total capacity.

All capacities shown are gross and have not considered indoor fan heat.
 To obtain net cooling capacities subtract indoor fan heat.
 TGC = Total Gross Cooling Capacity
 SHC = Sensible Heat Capacity



Performance Data System

Table PD-13 — Gross Cooling Capacities (MBh) - Both Compressors - TTA155C Condensing Unit With TWE155B Air Handler (I-P)

CFM		Ambient Temperature (°F)																							
		85						95						105						115					
		Enter. Dry Bulb		Entering Wet Bulb (°F)												Enter. Dry Bulb									
Airflow	(°F)	TGC	SHC	TGC	SHC	TGC	SHC	TGC	SHC	TGC	SHC	TGC	SHC	TGC	SHC	TGC	SHC	TGC	SHC	TGC	SHC	TGC	SHC		
4500	75	153.7	120.4	169.7	101.2	186.5	69.1	148.4	117.7	163.7	98.8	179.5	66.6	142.2	114.5	156.6	95.9	171.4	63.8	135.1	110.9	148.7	92.7	162.4	60.8
	80	154.5	140.2	170.0	116.1	187.2	90.5	149.4	137.5	164.1	113.4	180.3	87.9	143.3	134.4	157.1	110.2	172.5	85.0	136.4	130.9	149.3	106.6	163.9	81.8
	85	157.6	157.6	170.9	135.9	187.9	111.2	153.2	153.2	164.9	133.1	181.1	108.6	147.9	147.9	158.0	129.9	173.4	105.7	141.9	141.9	150.2	126.3	164.9	102.6
5000	75	156.9	125.9	172.9	99.6	189.5	70.2	151.4	123.1	166.6	97.0	182.1	67.7	144.9	119.8	159.3	93.9	173.8	64.9	137.6	116.1	151.2	90.6	164.7	61.8
	80	158.0	147.6	173.4	121.1	190.4	93.5	152.6	144.9	167.1	118.3	183.3	90.9	146.4	141.7	159.9	115.0	175.3	87.9	139.4	138.1	151.9	111.3	166.4	84.8
	85	162.9	162.9	174.2	142.7	191.2	116.1	158.2	158.2	168.0	139.8	184.2	113.5	152.7	152.7	160.8	136.5	175.7	109.7	146.3	146.3	152.8	132.9	167.0	106.1
5500	75	159.6	131.1	175.5	102.9	191.8	71.5	153.9	128.2	169.0	100.2	184.3	68.9	147.2	124.8	161.5	97.2	175.8	66.1	139.6	121.1	152.5	92.8	166.4	62.8
	80	161.1	154.8	176.1	125.8	193.0	96.4	155.6	152.0	169.7	122.9	185.7	93.7	149.3	148.7	162.3	119.6	177.5	90.7	142.1	142.1	154.0	115.9	168.5	87.5
	85	167.6	167.6	177.0	149.2	193.4	120.0	162.6	162.6	170.6	146.2	186.2	117.1	156.8	156.8	163.2	142.9	178.1	113.8	150.2	150.2	155.1	139.3	169.2	110.2
6000	75	161.9	136.0	177.8	106.1	193.8	72.7	156.0	133.1	171.1	103.3	186.1	70.0	149.1	129.7	162.8	99.2	177.4	66.9	141.4	125.9	154.3	95.4	167.8	63.6
	80	163.9	161.7	178.5	130.3	195.3	99.1	157.7	157.7	171.9	127.4	187.8	96.4	151.9	151.9	164.3	124.0	179.4	93.4	145.3	145.3	155.9	120.2	170.2	90.2
	85	171.6	171.6	179.4	155.4	195.8	124.0	166.4	166.4	172.8	152.5	188.5	121.1	160.4	160.4	165.4	149.1	180.2	117.8	153.5	153.5	157.1	140.5	171.1	114.1
90	180.6	180.6	181.9	181.2	196.9	149.0	175.2	175.2	175.3	175.3	189.5	146.1	168.9	168.9	169.0	169.0	181.3	142.8	161.9	161.9	162.0	162.0	172.3	139.2	

Equal TGC and SHC values constitute dry coil conditions. Total Gross Cooling (TGC) shown to the left is not applicable. In this case the Sensible Heat Capacity (SHC) is the total capacity.

All capacities shown are gross and have not considered indoor fan heat.
 To obtain net cooling capacities subtract indoor fan heat.
 TGC = Total Gross Cooling Capacity
 SHC = Sensible Heat Capacity

Table PD-13 — Gross Cooling Capacities (kW) - Both Compressors - TTA155C Condensing Unit With TWE155B Air Handler (SI)

m³/h		Ambient Temperature (°C)																							
		29.4				35.0				40.6				46.1											
		Enter. Dry Bulb		Entering Wet Bulb (°C)								Enter. Dry Bulb													
Airflow	(°C)	TGC	SHC	TGC	SHC	TGC	SHC	TGC	SHC	TGC	SHC	TGC	SHC	TGC	SHC	TGC	SHC	TGC	SHC	TGC	SHC				
7646	24	45.0	35.3	49.7	29.6	54.6	20.2	43.5	34.5	47.9	28.9	52.6	19.5	41.6	33.5	45.9	28.1	50.2	18.7	39.6	32.5	43.6	27.2	47.6	17.8
	27	45.2	41.1	49.8	34.0	54.8	26.5	43.7	40.3	48.0	33.2	52.8	25.7	41.9	39.4	46.0	32.3	50.5	24.9	39.9	38.3	43.7	31.2	48.0	24.0
	29	46.1	46.1	50.0	39.8	55.0	32.6	44.9	44.9	48.3	39.0	53.0	31.8	43.3	43.3	46.3	38.0	50.8	31.0	41.6	41.6	44.0	37.0	48.3	30.0
8495	24	45.9	36.9	50.6	29.2	55.5	20.6	44.3	36.0	48.8	28.4	53.3	19.8	42.4	35.1	46.6	27.5	50.9	19.0	40.3	34.0	44.3	26.5	48.2	18.1
	27	46.3	43.2	50.8	35.5	55.7	27.4	44.7	42.4	48.9	34.6	53.7	26.6	42.9	41.5	46.8	33.7	51.3	25.8	40.8	40.4	44.5	32.6	48.7	24.8
	29	47.7	47.7	51.0	41.8	56.0	34.0	46.3	46.3	49.2	40.9	53.9	33.2	44.7	44.7	47.1	40.0	51.4	32.1	42.8	42.8	44.7	38.9	48.9	31.1
9345	24	46.7	38.4	51.4	30.1	56.2	20.9	45.1	37.5	49.5	29.3	54.0	20.2	43.1	36.6	47.3	28.4	51.5	19.3	40.9	35.4	44.7	27.2	48.7	18.4
	27	47.2	45.3	51.6	36.8	56.5	28.2	45.6	44.5	49.7	36.0	54.4	27.4	43.7	43.6	47.5	35.0	52.0	26.6	41.6	41.6	45.1	33.9	49.3	25.6
	29	49.1	49.1	51.8	43.7	56.6	35.1	47.6	47.6	49.9	42.8	54.5	34.3	45.9	45.9	47.8	41.9	52.2	33.3	44.0	44.0	45.4	40.8	49.6	32.3
10194	24	47.4	39.8	52.1	31.1	56.7	21.3	45.7	39.0	50.1	30.3	54.5	20.5	43.7	38.0	47.7	29.1	52.0	19.6	41.4	36.9	45.2	27.9	49.1	18.6
	27	48.0	47.3	52.3	38.2	57.2	29.0	46.2	46.2	50.3	37.3	55.0	28.2	44.5	44.5	48.1	36.3	52.5	27.3	42.5	42.5	45.6	35.2	49.8	26.4
	29	50.3	50.3	52.5	45.5	57.3	36.3	48.7	48.7	50.6	44.6	55.2	35.5	47.0	47.0	48.4	43.7	52.8	34.5	45.0	45.0	46.0	42.6	50.1	33.4
32	52.9	52.9	53.3	53.1	57.6	43.6	51.3	51.3	51.3	51.3	55.5	42.8	49.4	49.4	49.5	49.5	53.1	41.8	47.4	47.4	47.4	47.4	50.4	40.8	

Equal TGC and SHC values constitute dry coil conditions. Total Gross Cooling (TGC) shown to the left is not applicable. In this case the Sensible Heat Capacity (SHC) is the total capacity.

All capacities shown are gross and have not considered indoor fan heat.
 To obtain net cooling capacities subtract indoor fan heat.
 TGC = Total Gross Cooling Capacity
 SHC = Sensible Heat Capacity



Performance Data

System

Table PD-14 — Gross Cooling Capacities (MBh) - Single Compressor - TTA155C Condensing Unit with TWE155B Air Handler (I-P)

CFM		Ambient Temperature (°F)																							
		85						95						105						115					
		Enter. Dry Bulb (°F)		Entering Wet Bulb (°F)																					
Airflow		61		67		73		61		67		73		61		67		73		61		67		73	
4500	75	94.3	92.3	103.0	67.8	112.7	43.8	91.7	91.0	99.8	66.5	108.7	42.4	88.2	88.2	96.0	64.8	104.3	41.0	84.6	84.6	91.6	62.9	99.3	39.4
	80	99.4	99.4	103.6	87.7	113.5	63.2	96.8	96.8	100.4	86.4	109.6	61.8	93.7	93.7	96.6	84.8	105.3	60.1	90.0	90.0	92.3	83.0	100.6	58.3
	85	105.3	105.3	105.4	105.4	114.2	83.1	102.5	102.5	102.6	102.6	110.4	81.7	99.2	99.2	99.3	99.3	106.1	80.1	95.4	95.4	95.5	95.5	101.4	78.3
	90	111.3	111.3	111.5	111.5	114.8	103.2	108.4	108.4	108.5	108.5	111.2	101.9	104.9	104.9	105.0	105.0	107.0	100.3	100.9	100.9	101.0	101.0	102.3	98.5
5000	75	95.8	95.8	104.2	72.0	113.7	43.9	93.3	93.3	100.9	70.8	109.5	42.6	90.1	90.1	97.0	69.3	105.0	41.1	86.4	86.4	92.5	65.6	100.0	39.5
	80	101.8	101.8	104.9	92.4	114.9	66.6	99.1	99.1	101.6	91.1	110.9	65.3	95.8	95.8	97.8	89.5	106.5	63.9	92.0	92.0	93.4	87.6	101.6	62.3
	85	107.9	107.9	108.0	108.0	115.4	87.3	105.0	105.0	105.0	105.0	111.6	85.9	101.5	101.5	101.6	101.6	107.2	84.3	97.6	97.6	97.6	97.6	102.3	82.5
	90	114.1	114.1	114.3	114.3	116.3	109.4	111.0	111.0	111.1	111.1	112.6	108.1	107.4	107.4	107.5	107.5	108.4	106.5	103.3	103.3	103.4	103.4	103.5	103.5
5500	75	97.7	97.7	105.2	73.3	114.5	44.7	95.0	95.0	101.8	71.9	110.2	43.4	91.8	91.8	97.8	70.2	105.6	41.9	88.0	88.0	93.2	68.2	100.4	40.3
	80	103.8	103.8	106.0	97.0	115.8	69.3	101.0	101.0	102.7	95.6	111.8	68.0	97.6	97.6	98.8	94.0	107.3	66.5	93.6	93.6	94.4	92.1	102.4	64.9
	85	110.1	110.1	110.2	110.2	116.4	91.5	107.0	107.0	107.1	107.1	112.5	90.0	103.4	103.4	103.5	103.5	108.1	88.4	99.4	99.4	99.4	99.4	103.1	86.5
	90	116.5	116.5	116.6	116.6	117.6	115.4	113.3	113.3	113.4	113.4	113.5	113.5	109.5	109.5	109.6	109.6	109.7	109.7	105.3	105.3	105.4	105.4	105.5	105.5
6000	75	99.3	99.3	106.0	75.9	115.1	45.5	96.6	96.6	102.6	74.5	110.7	44.1	93.2	93.2	98.5	72.7	106.1	42.6	89.3	89.3	93.9	70.7	100.8	41.0
	80	105.6	105.6	107.0	101.4	116.6	71.8	102.6	102.6	103.7	100.0	112.5	70.5	99.1	99.1	99.8	98.3	107.9	69.1	95.1	95.1	95.1	95.1	103.0	67.5
	85	112.0	112.0	112.1	112.1	117.2	95.5	108.9	108.9	109.0	109.0	113.3	94.0	105.2	105.2	105.2	105.2	108.8	92.3	101.0	101.0	101.0	101.0	103.9	90.5
	90	118.5	118.5	118.6	118.6	118.7	118.7	115.2	115.2	115.3	115.3	115.4	115.4	111.4	111.4	111.5	111.5	111.5	111.5	107.0	107.0	107.1	107.1	107.2	107.2

Equal TGC and SHC values constitute dry coil conditions. Total Gross Cooling (TGC) shown to the left is not applicable. In this case the Sensible Heat Capacity (SHC) is the total capacity.

All capacities shown are gross and have not considered indoor fan heat.
 To obtain net cooling capacities subtract indoor fan heat.
 TGC = Total Gross Cooling Capacity
 SHC = Sensible Heat Capacity

Table PD-14 — Gross Cooling Capacities (kW) - Single Compressor - TTA155C Condensing Unit with TWE155B Air Handler (SI)

m³/h		Ambient Temperature (°C)																							
		29.4				35.0				40.6				46.1											
		Enter. Dry Bulb (°C)		Entering Wet Bulb (°C)																					
Airflow		16.1		19.4		22.8		16.1		19.4		22.8		16.1		19.4		22.8							
7646	24	27.6	27.0	30.2	19.9	33.0	12.8	26.8	26.7	29.2	19.5	31.8	12.4	25.8	25.8	28.1	19.0	30.5	12.0	24.8	24.8	26.8	18.4	29.1	11.6
	27	29.1	29.1	30.3	25.7	33.2	18.5	28.4	28.4	29.4	25.3	32.1	18.1	27.4	27.4	28.3	24.8	30.8	17.6	26.3	26.3	27.0	24.3	29.4	17.1
	29	30.8	30.8	30.9	30.9	33.4	24.3	30.0	30.0	30.1	30.1	32.3	23.9	29.1	29.1	29.1	29.1	31.1	23.4	27.9	27.9	28.0	28.0	29.7	22.9
	32	32.6	32.6	32.6	32.6	33.6	30.2	31.7	31.7	31.8	31.8	32.6	29.8	30.7	30.7	30.7	30.7	31.3	29.4	29.6	29.6	29.6	29.6	30.0	28.9
8495	24	28.0	28.0	30.5	21.1	33.3	12.9	27.3	27.3	29.6	20.7	32.1	12.5	26.4	26.4	28.4	20.3	30.8	12.0	25.3	25.3	27.1	19.2	29.3	11.6
	27	29.8	29.8	30.7	27.1	33.6	19.5	29.0	29.0	29.8	26.7	32.5	19.1	28.0	28.0	28.6	26.2	31.2	18.7	26.9	26.9	27.3	25.7	29.8	18.2
	29	31.6	31.6	31.6	31.6	33.8	25.6	30.7	30.7	30.8	30.8	32.7	25.2	29.7	29.7	29.7	29.7	31.4	24.7	28.6	28.6	28.6	28.6	30.0	24.2
	32	33.4	33.4	33.5	33.5	34.0	32.0	32.5	32.5	32.5	32.5	33.0	31.6	31.4	31.4	31.5	31.5	31.7	31.2	30.2	30.2	30.3	30.3	30.3	30.3
9345	24	28.6	28.6	30.8	21.5	33.5	13.1	27.8	27.8	29.8	21.1	32.3	12.7	26.9	26.9	28.6	20.6	30.9	12.3	25.8	25.8	27.3	20.0	29.4	11.8
	27	30.4	30.4	31.0	28.4	33.9	20.3	29.6	29.6	30.1	28.0	32.7	19.9	28.6	28.6	28.9	27.5	31.4	19.5	27.4	27.4	27.6	27.0	30.0	19.0
	29	32.2	32.2	32.3	32.3	34.1	26.8	31.3	31.3	31.4	31.4	32.9	26.4	30.3	30.3	30.3	31.6	25.9	29.1	29.1	29.1	29.1	29.1	30.2	25.3
	32	34.1	34.1	34.1	34.1	34.4	33.8	33.2	33.2	33.2	33.2	33.2	33.2	32.1	32.1	32.1	32.1	32.1	32.1	30.8	30.8	30.9	30.9	30.9	30.9
10194	24	29.1	29.1	31.0	22.2	33.7	13.3	28.3	28.3	30.0	21.8	32.4	12.9	27.3	27.3	28.8	21.3	31.1	12.5	26.1	26.1	27.5	20.7	29.5	12.0
	27	30.9	30.9	31.3	29.7	34.1	21.0	30.1	30.1	30.4	29.3	32.9	20.6	29.0	29.0	29.2	28.8	31.6	20.2	27.8	27.8	27.9	27.9	30.1	19.8
	29	32.8	32.8	32.8	32.8	34.3	28.0	31.9	31.9	31.9	31.9	33.2	27.5	30.8	30.8	30.8	30.8	31.9	27.0	29.6	29.6	29.6	29.6	30.4	26.5
	32	34.7	34.7	34.7	34.7	34.7	34.7	33.7	33.7	33.8	33.8	33.8	33.8	32.6	32.6	32.6	32.6	32.7	32.7	31.3	31.3	31.4	31.4	31.4	31.4

Equal TGC and SHC values constitute dry coil conditions. Total Gross Cooling (TGC) shown to the left is not applicable. In this case the Sensible Heat Capacity (SHC) is the total capacity.

All capacities shown are gross and have not considered indoor fan heat.
 To obtain net cooling capacities subtract indoor fan heat.
 TGC = Total Gross Cooling Capacity
 SHC = Sensible Heat Capacity



Performance Data System

Table PD-15 — Gross Cooling Capacities (MBh) TTA200B Condensing Unit with TWE200B Air Handler (I-P)

CFM		Ambient Temperature (°F)																							
		85						95						105						115					
		Enter. Dry Bulb		Entering Wet Bulb (°F)																					
Airflow	(°F)	TGC	SHC	TGC	SHC	TGC	SHC	TGC	SHC	TGC	SHC	TGC	SHC	TGC	SHC	TGC	SHC	TGC	SHC	TGC	SHC	TGC	SHC	TGC	SHC
6000	75	203.5	160.6	224.5	134.3	247.0	91.4	195.8	156.6	215.9	130.8	237.4	88.1	187.6	152.4	207.0	127.2	227.3	84.6	179.2	148.2	197.8	123.5	216.6	81.0
	80	204.7	187.3	224.9	154.7	247.8	120.1	197.2	183.4	216.5	150.8	238.4	116.6	189.3	179.4	207.7	146.8	228.7	113.0	181.1	175.3	198.6	142.6	218.6	109.2
	85	209.3	209.3	226.0	181.2	248.8	148.0	202.9	202.9	217.6	177.4	239.4	144.5	196.1	196.1	208.8	173.4	229.8	140.8	189.0	189.0	199.7	169.2	219.8	137.2
	90	220.0	220.0	227.3	208.2	249.1	174.6	213.4	213.4	219.1	204.4	239.8	170.9	206.5	206.5	210.7	200.5	230.3	167.0	199.3	199.3	202.0	196.5	220.4	162.9
6675	75	207.6	168.0	228.8	132.3	250.9	93.0	199.6	164.0	219.9	128.6	240.9	89.6	191.2	159.7	210.7	124.8	230.5	86.0	182.5	155.4	201.2	121.0	219.8	82.4
	80	209.3	197.5	229.3	161.5	252.0	124.2	201.6	193.5	220.5	157.5	242.3	120.6	193.6	189.5	211.4	153.4	232.3	117.0	185.4	185.3	202.1	149.2	221.9	113.2
	85	216.3	216.3	230.4	190.6	253.1	154.7	209.6	209.6	221.6	186.6	243.5	151.1	202.4	202.4	212.6	182.6	232.8	146.5	195.0	195.0	203.3	178.4	222.5	142.3
	90	227.5	227.5	232.3	220.2	253.6	183.3	220.6	220.6	224.0	216.4	244.0	179.4	213.3	213.3	215.4	212.5	234.1	175.5	205.7	205.7	205.9	205.9	223.9	171.4
7350	75	211.1	175.1	232.2	136.8	254.0	94.7	202.8	171.0	223.1	133.1	243.7	91.2	194.2	166.7	213.7	129.3	233.2	87.5	185.3	162.3	203.0	124.3	222.2	83.7
	80	213.4	207.2	232.9	168.0	255.5	128.1	205.6	203.3	223.9	163.9	245.5	124.5	196.9	196.9	214.6	159.8	235.3	120.8	189.3	189.3	205.0	155.5	224.6	117.0
	85	222.4	222.4	234.0	199.5	256.7	161.0	215.4	215.4	225.1	195.5	246.1	156.2	208.0	208.0	216.0	191.4	236.0	152.2	200.3	200.3	206.5	187.2	225.5	148.0
	90	234.1	234.1	236.9	231.9	257.3	191.6	226.8	226.8	228.5	228.1	247.5	187.7	219.2	219.2	219.5	219.5	237.3	183.6	211.3	211.3	211.5	211.5	226.9	179.5
8025	75	214.1	181.9	235.2	141.1	256.7	96.2	205.6	177.7	225.8	137.3	246.2	92.5	196.8	173.4	215.4	132.3	235.3	88.7	187.8	168.9	205.5	127.9	224.1	84.8
	80	217.3	216.7	236.0	174.2	258.5	131.8	208.9	208.9	226.8	170.1	248.3	128.1	201.4	201.4	217.3	165.8	237.8	124.4	193.6	193.6	207.5	161.5	226.9	120.6
	85	227.9	227.9	237.3	208.1	259.2	165.7	220.9	220.9	228.3	204.1	249.1	161.8	212.9	212.9	218.9	200.0	238.7	157.7	204.9	204.9	209.4	195.7	228.0	153.4
	90	239.9	239.9	240.1	240.1	260.5	199.6	232.4	232.4	232.6	232.6	250.4	195.6	224.5	224.5	224.7	224.7	240.1	191.5	216.3	216.3	216.5	216.5	229.4	187.3

Equal TGC and SHC values constitute dry coil conditions. Total Gross Cooling (TGC) shown to the left is not applicable. In this case the Sensible Heat Capacity (SHC) is the total capacity.

All capacities shown are gross and have not considered indoor fan heat.
 To obtain net cooling capacities subtract indoor fan heat.
 TGC = Total Gross Cooling Capacity
 SHC = Sensible Heat Capacity

Table PD-15 — Gross Cooling Capacities (MBh) TTA200B Condensing Unit with TWE200B Air Handler (SI)

m³/h		Ambient Temperature (°C)																							
		29.4				35.0				40.6				46.1											
		Enter. Dry Bulb		Entering Wet Bulb (°C)																					
Airflow	(°C)	TGC	SHC	TGC	SHC	TGC	SHC	TGC	SHC	TGC	SHC	TGC	SHC	TGC	SHC	TGC	SHC	TGC	SHC	TGC	SHC	TGC	SHC		
10194	24	59.6	47.0	65.7	39.3	72.3	26.8	57.3	45.8	63.2	38.3	69.5	25.8	54.9	44.6	60.6	37.3	66.5	24.8	52.5	43.4	57.9	36.2	63.4	23.7
	29	61.3	61.3	66.2	53.1	72.8	43.3	59.4	59.4	63.7	51.9	70.1	42.3	57.4	57.4	61.1	50.8	67.3	41.2	55.3	55.3	58.5	49.6	64.3	40.2
	32	64.4	64.4	66.6	61.0	72.9	51.1	62.5	62.5	64.2	59.8	70.2	50.0	60.5	60.5	61.7	58.7	67.4	48.9	58.3	58.3	59.1	57.5	64.5	47.7
	24	60.8	49.2	67.0	38.7	73.5	27.2	58.4	48.0	64.4	37.7	70.5	26.2	56.0	46.8	61.7	36.6	67.5	25.2	53.4	45.5	58.9	35.4	64.3	24.1
11341	27	61.3	57.8	67.1	47.3	73.8	36.4	59.0	56.7	64.6	46.1	71.0	35.3	56.7	55.5	61.9	44.9	68.0	34.2	54.3	54.3	59.2	43.7	65.0	33.2
	29	63.3	63.3	67.5	55.8	74.1	45.3	61.4	61.4	64.9	54.6	71.3	44.2	59.3	59.3	62.2	53.5	68.2	42.9	57.1	57.1	59.5	52.2	65.2	41.7
	32	66.6	66.6	68.0	64.5	74.2	53.7	64.6	64.6	65.6	63.4	71.5	52.5	62.4	62.4	63.1	62.2	68.6	51.4	60.2	60.2	60.3	60.3	65.6	50.2
	24	61.8	51.3	68.0	40.1	74.4	27.7	59.4	50.1	65.3	39.0	71.4	26.7	56.9	48.8	62.6	37.8	68.3	25.6	54.3	47.5	59.4	36.4	65.0	24.5
12488	27	62.5	60.7	68.2	49.2	74.8	37.5	60.2	59.5	65.6	48.0	71.9	36.4	57.6	57.6	62.8	46.8	68.9	35.4	55.4	55.4	60.0	45.5	65.8	34.3
	29	65.1	65.1	68.5	58.4	75.2	47.1	63.1	63.1	65.9	57.2	72.1	45.7	60.9	60.9	63.2	56.0	69.1	44.6	58.6	58.6	60.5	54.8	66.0	43.3
	32	68.5	68.5	69.4	67.9	75.3	56.1	66.4	66.4	66.9	66.8	72.5	55.0	64.2	64.2	64.3	64.3	69.5	53.8	61.9	61.9	61.9	61.9	66.4	52.6
	24	62.7	53.3	68.9	41.3	75.2	28.2	60.2	52.0	66.1	40.2	72.1	27.1	57.6	50.8	63.1	38.7	68.9	26.0	55.0	49.5	60.2	37.5	65.6	24.8
13634	27	63.6	63.5	69.1	51.0	75.7	38.6	61.2	61.2	66.4	49.8	72.7	37.5	59.0	59.0	63.6	48.6	69.6	36.4	56.7	56.7	60.7	47.3	66.4	35.3
	29	66.7	66.7	69.5	60.9	75.9	48.5	64.6	64.6	66.8	59.8	72.9	47.4	62.3	62.3	64.1	58.6	69.9	46.2	60.0	60.0	61.3	57.3	66.8	44.9
	32	70.2	70.2	70.3	70.3	76.3	58.4	68.0	68.0	68.1	68.1	73.3	57.3	65.7	65.7	65.8	65.8	70.3	56.1	63.3	63.3	63.4	63.4	67.2	54.9
	24	62.7	53.3	68.9	41.3	75.2	28.2	60.2	52.0	66.1	40.2	72.1	27.1	57.6	50.8	63.1	38.7	68.9	26.0	55.0	49.5	60.2	37.5	65.6	24.8

Equal TGC and SHC values constitute dry coil conditions. Total Gross Cooling (TGC) shown to the left is not applicable. In this case the Sensible Heat Capacity (SHC) is the total capacity.

All capacities shown are gross and have not considered indoor fan heat.
 To obtain net cooling capacities subtract indoor fan heat.
 TGC = Total Gross Cooling Capacity
 SHC = Sensible Heat Capacity



Performance Data

System

Table PD-16 – Gross Cooling Capacities (kW) - TTA200F w/ TWE200E - (SI)

m³/h Airflow	Enter. Dry Bulb Temp (C)	Ambient Temperature (C)																							
		30						35						40						45					
		Entering Wet Bulb Temperature (C)																							
		16		19		22		16		19		22		16		19		22		16		19		22	
MBH	SHC	MBH	SHC	MBH	SHC	MBH	SHC	MBH	SHC	MBH	SHC	MBH	SHC	MBH	SHC	MBH	SHC	MBH	SHC	MBH	SHC	MBH	SHC		
10194	24	60.2	49.8	65.8	35.8	71.9	20.9	57.4	48.6	62.8	34.5	68.6	19.7	54.4	47.3	59.5	33.2	65.0	18.6	51.1	45.9	55.8	31.8	60.8	16.8
	27	60.8	60.1	66.2	46.0	72.3	31.2	58.1	58.0	63.2	44.8	69.0	30.1	55.3	55.1	59.8	43.5	65.3	28.9	52.0	51.9	56.2	42.2	61.2	27.7
	30	62.0	61.8	66.6	56.3	72.6	41.7	59.8	59.5	63.7	55.2	69.3	40.5	57.2	57.1	60.3	54.0	65.7	39.2	54.3	54.2	56.7	52.7	61.6	37.8
	33	65.2	65.1	67.4	66.8	73.0	51.9	62.8	62.7	64.5	64.2	69.7	50.9	60.2	60.1	61.3	61.3	66.0	49.7	57.2	57.1	57.5	57.4	62.0	48.6
11341	24	61.6	53.0	67.3	37.5	73.4	21.0	58.8	51.8	64.1	36.2	69.8	19.6	55.7	50.4	60.7	34.9	66.1	18.5	52.3	49.0	56.9	33.4	61.8	17.3
	27	62.5	62.4	67.7	48.8	73.7	32.5	59.8	59.8	64.6	47.6	70.3	31.3	56.6	56.6	61.1	46.3	66.5	30.1	53.2	53.0	57.3	45.0	62.2	28.9
	30	64.3	64.2	68.2	60.4	74.2	44.2	61.9	61.8	65.1	59.2	70.7	42.9	59.2	58.9	61.7	58.0	66.9	41.7	56.1	56.0	57.9	56.6	62.7	40.5
	33	67.6	67.4	69.2	69.2	74.5	55.6	65.1	65.1	66.2	65.9	71.1	54.6	62.3	62.1	62.5	62.4	67.4	53.5	59.1	58.9	59.2	58.9	63.2	52.3
12488	24	62.9	56.1	68.5	39.1	74.6	20.9	60.0	54.9	65.3	37.8	71.0	20.0	56.8	53.5	61.7	36.4	67.1	18.9	53.3	52.0	57.7	34.6	62.7	17.3
	27	64.1	63.9	68.9	51.6	74.9	33.7	61.0	61.0	65.7	50.4	71.4	32.6	57.7	57.4	62.2	49.2	67.5	31.4	54.6	54.5	58.3	47.9	63.1	30.0
	30	66.3	66.2	69.6	64.3	75.4	46.4	63.7	63.6	66.4	63.2	71.9	45.4	60.9	60.7	62.9	61.9	68.0	44.2	57.7	57.4	59.1	58.9	63.6	43.1
	33	69.7	69.5	70.7	70.6	75.9	59.3	67.1	66.8	67.3	67.1	72.4	58.3	64.1	63.9	64.2	64.2	68.5	57.2	60.8	60.7	60.9	60.7	64.2	56.1
13634	24	64.1	59.2	69.5	40.7	75.6	21.4	61.0	57.9	66.2	39.5	72.0	20.0	57.7	56.5	62.6	38.2	67.9	18.8	54.2	53.9	58.5	36.7	63.5	17.5
	27	64.9	64.8	70.1	54.4	76.1	35.0	62.0	61.8	66.8	53.3	72.5	34.0	59.1	58.9	63.2	52.1	68.3	32.9	56.0	55.7	59.2	50.8	63.9	31.5
	30	68.1	68.0	70.9	68.2	76.6	49.1	65.4	65.4	67.6	67.0	72.9	47.9	62.4	62.4	64.0	63.9	68.9	46.8	59.1	58.9	60.2	60.1	64.5	45.6
	33	71.6	71.5	71.7	71.5	77.1	63.0	68.9	68.6	68.9	68.9	73.5	62.0	65.8	65.6	65.8	65.6	69.5	60.9	62.3	62.1	62.3	62.1	65.1	59.8

NOTES:

1. All capacities shown are gross and have not considered indoor fan heat. To obtain net cooling, subtract indoor fan heat.
2. MBH = Total Gross Capacity
3. SHC = Sensible Heat Capacity



Performance Data

Condensing Unit

Table PD-17— Cooling Performance (MBh) TTA075A Condensing Unit Only (I-P)

ODTemp °F		Suction Reference Temperature °F					
		30	35	40	45	50	55
65	Head press PSIG	161	167	172	178	184	190
	Cap. Btuh/1000	72.3	80.0	88.0	96.3	104.9	113.5
	OD Unit KW	4.91	5.01	5.12	5.24	5.37	5.50
75	Head press PSIG	187	193	198	205	211	217
	Cap. Btuh/1000	70.4	77.8	85.4	93.2	101.1	109.1
	OD Unit KW	5.40	5.51	5.63	5.76	5.89	6.03
85	Head press PSIG	215	221	227	233	240	247
	Cap. Btuh/1000	67.7	74.7	81.9	89.3	96.8	104.4
	OD Unit KW	5.97	6.10	6.23	6.37	6.50	6.65
95	Head press PSIG	245	251	258	265	271	279
	Cap. Btuh/1000	64.5	71.1	77.9	84.9	91.9	99.1
	OD Unit KW	6.65	6.78	6.91	7.05	7.19	7.34
105	Head press PSIG	278	284	291	298	305	313
	Cap. Btuh/1000	60.7	66.9	73.3	79.8	86.5	93.3
	OD Unit KW	7.40	7.53	7.66	7.80	7.94	8.09
115	Head press PSIG	313	320	327	334	341	349
	Cap. Btuh/1000	56.4	62.2	68.2	74.4	80.7	87.2
	OD Unit KW	8.23	8.35	8.48	8.62	8.76	8.91

Performance Data Calculated at 15 deg. subcooling and 15 deg. superheat.

Table PD-17— Cooling Performance (kW) TTA075A Condensing Unit Only (SI)

ODTemp °C		Suction Reference Temperature °C					
		-1.1	1.7	4.4	7.2	10.0	12.8
18.3	Head pressure (kPA)	1113	1149	1187	1228	1270	1313
	Capacity (kW)	21.2	23.4	25.8	28.2	30.7	33.2
	OD Unit Power (kW)	4.91	5.01	5.12	5.24	5.37	5.50
23.9	Head pressure (kPA)	1290	1328	1368	1410	1453	1498
	Capacity (kW)	20.6	22.8	25.0	27.3	29.6	32.0
	OD Unit Power (kW)	5.40	5.51	5.63	5.76	5.89	6.03
29.4	Head pressure (kPA)	1481	1522	1565	1609	1654	1701
	Capacity (kW)	19.8	21.9	24.0	26.2	28.3	30.6
	OD Unit Power (kW)	5.97	6.10	6.23	6.37	6.50	6.65
35.0	Head pressure (kPA)	1690	1733	1778	1824	1871	1921
	Capacity (kW)	18.9	20.8	22.8	24.8	26.9	29.0
	OD Unit Power (kW)	6.65	6.78	6.91	7.05	7.19	7.34
40.6	Head pressure (kPA)	1915	1960	2007	2055	2104	2156
	Capacity (kW)	17.8	19.6	21.5	23.4	25.3	27.3
	OD Unit Power (kW)	7.40	7.53	7.66	7.80	7.94	8.09
46.1	Head pressure (kPA)	2156	2203	2251	2301	2353	2407
	Capacity (kW)	16.5	18.2	20.0	21.8	23.6	25.5
	OD Unit Power (kW)	8.23	8.35	8.48	8.62	8.76	8.91

Performance Data Calculated at 8.3 deg. subcooling and 8.3 deg. superheat.



Performance Data

Condensing Unit

Table PD-18 — Cooling Performance (MBh) TTA085A Condensing Unit Only (I-P)

ODTemp °F		Suction Reference Temperature °F					
		30	35	40	45	50	55
65	Head press PSIG	154	159	164	169	175	180
	Cap. Btuh/1000	82.0	90.5	99.4	108.7	118.4	128.5
	OD Unit KW	4.93	5.03	5.13	5.24	5.36	5.49
75	Head press PSIG	178	183	188	194	199	205
	Cap. Btuh/1000	78.5	86.5	94.9	103.8	113.0	122.7
	OD Unit KW	5.41	5.51	5.63	5.75	5.88	6.02
85	Head press PSIG	205	210	215	221	227	233
	Cap. Btuh/1000	74.7	82.3	90.3	98.7	107.6	116.9
	OD Unit KW	6.00	6.11	6.23	6.36	6.49	6.64
95	Head press PSIG	234	239	245	251	257	264
	Cap. Btuh/1000	70.7	77.9	85.5	93.6	102.1	111.0
	OD Unit KW	6.69	6.80	6.93	7.07	7.22	7.37
105	Head press PSIG	265	271	277	283	290	297
	Cap. Btuh/1000	66.4	73.3	80.7	88.4	96.6	105.0
	OD Unit KW	7.48	7.61	7.74	7.89	8.04	8.20
115	Head press PSIG	300	306	312	319	326	333
	Cap. Btuh/1000	61.9	68.6	75.7	83.2	91.0	99.1
	OD Unit KW	8.37	8.51	8.66	8.81	8.97	9.13

Performance Data Calculated at 15 deg. subcooling and 15 deg. superheat.

Table PD-18 — Cooling Performance (kW) TTA085A Condensing Unit Only (SI)

ODTemp °C		Suction Reference Temperature °C					
		-1.1	1.7	4.4	7.2	10.0	12.8
18.3	Head pressure (kPA)	1063	1095	1129	1165	1203	1244
	Capacity (kW)	24.0	26.5	29.1	31.8	34.7	37.6
	OD Unit Power (kW)	4.93	5.03	5.13	5.24	5.36	5.49
23.9	Head pressure (kPA)	1229	1262	1297	1334	1374	1416
	Capacity (kW)	23.0	25.3	27.8	30.4	33.1	35.9
	OD Unit Power (kW)	5.41	5.51	5.63	5.75	5.88	6.02
29.4	Head pressure (kPA)	1412	1446	1482	1521	1563	1607
	Capacity (kW)	21.9	24.1	26.4	28.9	31.5	34.2
	OD Unit Power (kW)	6.00	6.11	6.23	6.36	6.49	6.64
35.0	Head pressure (kPA)	1612	1648	1686	1727	1771	1817
	Capacity (kW)	20.7	22.8	25.0	27.4	29.9	32.5
	OD Unit Power (kW)	6.69	6.80	6.93	7.07	7.22	7.37
40.6	Head pressure (kPA)	1830	1869	1910	1953	1999	2047
	Capacity (kW)	19.4	21.5	23.6	25.9	28.3	30.8
	OD Unit Power (kW)	7.48	7.61	7.74	7.89	8.04	8.20
46.1	Head pressure (kPA)	2067	2109	2153	2199	2246	2297
	Capacity (kW)	18.1	20.1	22.2	24.4	26.6	29.0
	OD Unit Power (kW)	8.37	8.51	8.66	8.81	8.97	9.13

Performance Data Calculated at 8.3 deg. subcooling and 8.3 deg. superheat.



Performance Data

Condensing Unit

Table PD-19 – Cooling Performance (MBh) TTA100A Condensing Unit Only (I-P)

ODTemp °F		Suction Reference Temperature °F					
		30	35	40	45	50	55
65	Head press PSIG	166	172	178	185	192	200
	Cap. Btuh/1000	101.6	111.9	122.6	133.8	145.5	157.6
	OD Unit KW	6.30	6.46	6.63	6.81	7.01	7.22
75	Head press PSIG	191	197	203	210	218	226
	Cap. Btuh/1000	97.1	106.8	116.9	127.6	138.7	150.3
	OD Unit KW	6.95	7.12	7.30	7.50	7.71	7.94
85	Head press PSIG	218	224	231	238	246	254
	Cap. Btuh/1000	92.3	101.4	111.1	121.3	131.9	143.0
	OD Unit KW	7.73	7.91	8.11	8.32	8.55	8.79
95	Head press PSIG	248	254	261	269	277	286
	Cap. Btuh/1000	87.1	95.8	105.1	114.8	125.0	135.7
	OD Unit KW	8.64	8.83	9.04	9.27	9.50	9.75
105	Head press PSIG	280	287	294	302	311	320
	Cap. Btuh/1000	81.6	90.1	99.0	108.4	118.1	128.3
	OD Unit KW	9.66	9.87	10.10	10.34	10.59	10.84
115	Head press PSIG	315	322	330	339	348	357
	Cap. Btuh/1000	76.0	84.1	92.8	101.8	111.1	120.8
	OD Unit KW	10.80	11.04	11.28	11.54	11.79	12.05

Performance Data Calculated at 15 deg. subcooling and 15 deg. superheat.

Table PD-19 – Cooling Performance (kW) TTA100A Condensing Unit Only (SI)

ODTemp °C		Suction Reference Temperature °C					
		-1.1	1.7	4.4	7.2	10.0	12.8
18.3	Head pressure (kPa)	1146	1187	1230	1276	1326	1378
	Capacity (kW)	29.8	32.8	35.9	39.2	42.6	46.1
	OD Unit Power (kW)	6.30	6.46	6.63	6.81	7.01	7.22
23.9	Head pressure (kPa)	1316	1358	1402	1450	1501	1556
	Capacity (kW)	28.4	31.3	34.2	37.4	40.6	44.0
	OD Unit Power (kW)	6.95	7.12	7.30	7.50	7.71	7.94
29.4	Head pressure (kPa)	1502	1546	1593	1643	1696	1753
	Capacity (kW)	27.0	29.7	32.5	35.5	38.6	41.9
	OD Unit Power (kW)	7.73	7.91	8.11	8.32	8.55	8.79
35.0	Head pressure (kPa)	1707	1753	1802	1854	1910	1969
	Capacity (kW)	25.5	28.1	30.8	33.6	36.6	39.7
	OD Unit Power (kW)	8.64	8.83	9.04	9.27	9.50	9.75
40.6	Head pressure (kPa)	1929	1977	2030	2085	2144	2205
	Capacity (kW)	23.9	26.4	29.0	31.7	34.6	37.6
	OD Unit Power (kW)	9.66	9.87	10.10	10.34	10.59	10.84
46.1	Head pressure (kPa)	2169	2221	2277	2335	2397	2461
	Capacity (kW)	22.2	24.6	27.2	29.8	32.5	35.4
	OD Unit Power (kW)	10.80	11.04	11.28	11.54	11.79	12.05

Performance Data Calculated at 8.3 deg. subcooling and 8.3 deg. superheat.



Performance Data

Condensing Unit

Table PD-20 — Cooling Performance (MBh) TTA100B Condensing Unit Only (I-P)

ODTemp °F		Suction Reference Temperature °F					
		30	35	40	45	50	55
65	Head press PSIG	159	163	169	174	180	186
	Cap. Btuh/1000	99.0	108.9	119.2	130.1	141.5	153.4
	OD Unit KW	6.08	6.30	6.54	6.81	7.10	7.43
75	Head press PSIG	184	189	194	200	207	214
	Cap. Btuh/1000	94.4	103.9	114.0	124.5	135.5	147.1
	OD Unit KW	6.66	6.90	7.16	7.45	7.77	8.11
85	Head press PSIG	211	217	223	229	236	243
	Cap. Btuh/1000	89.6	98.8	108.6	118.7	129.4	140.5
	OD Unit KW	7.35	7.60	7.88	8.19	8.52	8.89
95	Head press PSIG	241	247	254	261	268	276
	Cap. Btuh/1000	84.8	93.7	103.0	112.8	123.1	133.7
	OD Unit KW	8.16	8.42	8.71	9.03	9.37	9.75
105	Head press PSIG	274	281	288	295	303	311
	Cap. Btuh/1000	79.8	88.4	97.4	106.8	116.5	126.6
	OD Unit KW	9.08	9.34	9.64	9.96	10.31	10.68
115	Head press PSIG	310	317	324	332	340	348
	Cap. Btuh/1000	74.8	83.1	91.6	100.6	109.8	119.3
	OD Unit KW	10.10	10.37	10.66	10.98	11.33	11.70

Performance Data Calculated at 15 deg. subcooling and 15 deg. superheat.

Table PD-20 — Cooling Performance (kW) TTA100B Condensing Unit Only (SI)

ODTemp °C		Suction Reference Temperature °C					
		-1.1	1.7	4.4	7.2	10.0	12.8
18.3	Head pressure (kPA)	1094	1127	1163	1201	1241	1285
	Capacity (kW)	29.0	31.9	34.9	38.1	41.4	44.9
	OD Unit Power (kW)	6.08	6.30	6.54	6.81	7.10	7.43
23.9	Head pressure (kPA)	1266	1302	1341	1382	1426	1473
	Capacity (kW)	27.6	30.4	33.4	36.5	39.7	43.1
	OD Unit Power (kW)	6.66	6.90	7.16	7.45	7.77	8.11
29.4	Head pressure (kPA)	1455	1494	1536	1581	1628	1678
	Capacity (kW)	26.2	28.9	31.8	34.8	37.9	41.1
	OD Unit Power (kW)	7.35	7.60	7.88	8.19	8.52	8.89
35.0	Head pressure (kPA)	1663	1705	1750	1798	1848	1901
	Capacity (kW)	24.8	27.4	30.2	33.0	36.0	39.1
	OD Unit Power (kW)	8.16	8.42	8.71	9.03	9.37	9.75
40.6	Head pressure (kPA)	1889	1934	1983	2033	2087	2142
	Capacity (kW)	23.4	25.9	28.5	31.3	34.1	37.1
	OD Unit Power (kW)	9.08	9.34	9.64	9.96	10.31	10.68
46.1	Head pressure (kPA)	2134	2183	2234	2288	2344	2402
	Capacity (kW)	21.9	24.3	26.8	29.5	32.2	34.9
	OD Unit Power (kW)	10.10	10.37	10.66	10.98	11.33	11.70

Performance Data Calculated at 8.3 deg. subcooling and 8.3 deg. superheat.



Performance Data

Condensing Unit

**Table PD-21 — Gross Cooling Capacities (MBh) - Both Compressors - (I-P)
TTA100C Condensing Unit Only**

ODTemp		Suction Reference Temperature °F					
°F		30	35	40	45	50	55
65	Head press PSIG	168.5	174.3	180.4	187.0	193.9	201.2
	Cap. Btuh/1000	100.5	110.4	120.9	131.8	143.2	154.9
	OD Unit KW	6.3	6.5	6.8	7.1	7.4	7.8
75	Head press PSIG	192.9	198.9	205.3	212.2	219.3	226.8
	Cap. Btuh/1000	95.7	105.3	115.5	126.0	136.9	148.0
	OD Unit KW	6.9	7.1	7.4	7.8	8.1	8.5
85	Head press PSIG	219.7	226.1	232.9	240.1	247.6	255.4
	Cap. Btuh/1000	90.8	100.1	109.9	120.0	130.5	141.1
	OD Unit KW	7.6	7.9	8.2	8.5	8.8	9.2
95	Head press PSIG	249.5	256.3	263.4	270.9	278.7	286.8
	Cap. Btuh/1000	85.9	94.9	104.2	113.9	123.9	133.9
	OD Unit KW	8.4	8.7	9.0	9.3	9.7	10.1
105	Head press PSIG	282.0	289.1	296.6	304.4	312.5	320.8
	Cap. Btuh/1000	80.9	89.5	98.5	107.7	117.1	126.6
	OD Unit KW	9.3	9.6	9.9	10.2	10.6	11.0
115	Head press PSIG	317.4	324.9	332.7	340.7	349.0	357.6
	Cap. Btuh/1000	75.8	84.1	92.6	101.3	110.2	119.1
	OD Unit KW	10.4	10.6	10.9	11.3	11.6	12.0

Performance Data Calculated at 15 deg. subcooling and 15 deg. superheat.

**Table PD-21 — Gross Cooling Capacities (kW) - Both Compressors - (SI)
TTA100C Condensing Unit Only**

ODTemp		Suction Reference Temperature °C					
°C		-1.1	1.7	4.4	7.2	10.0	12.8
18.3	Head pressure (kPA)	1162	1202	1244	1289	1337	1387
	Capacity (kW)	29.4	32.3	35.4	38.6	41.9	45.4
	OD Unit Power (kW)	6.30	6.54	6.82	7.12	7.45	7.80
23.9	Head pressure (kPA)	1330	1372	1416	1463	1512	1564
	Capacity (kW)	28.0	30.8	33.8	36.9	40.1	43.3
	OD Unit Power (kW)	6.89	7.15	7.43	7.75	8.09	8.46
29.4	Head pressure (kPA)	1515	1559	1606	1656	1708	1761
	Capacity (kW)	26.6	29.3	32.2	35.1	38.2	41.3
	OD Unit Power (kW)	7.58	7.86	8.16	8.48	8.84	9.22
35.0	Head pressure (kPA)	1720	1767	1816	1868	1921	1977
	Capacity (kW)	25.2	27.8	30.5	33.4	36.3	39.2
	OD Unit Power (kW)	8.40	8.68	8.98	9.31	9.67	10.06
40.6	Head pressure (kPA)	1944	1994	2045	2099	2154	2212
	Capacity (kW)	23.7	26.2	28.8	31.5	34.3	37.1
	OD Unit Power (kW)	9.32	9.60	9.91	10.24	10.60	10.98
46.1	Head pressure (kPA)	2188	2240	2294	2349	2407	2466
	Capacity (kW)	22.2	24.6	27.1	29.7	32.3	34.9
	OD Unit Power (kW)	10.35	10.63	10.93	11.25	11.60	11.98

Performance Data Calculated at 8.3 deg. subcooling and 8.3 deg. superheat.



Performance Data

Condensing Unit

Table PD-22 — Gross Cooling Capacities (MBh) - Single Compressor - (I-P)
TTA100C Condensing Unit Only

OD Temp °F		Suction Reference Temperature °F					
		30	35	40	45	50	55
65	Head press PSIG	138.6	141.3	144.1	147.0	150.1	153.4
	Cap. Btuh/1000	51.3	56.5	61.9	67.7	73.7	80.1
	OD Unit KW	3.1	3.2	3.3	3.4	3.5	3.6
75	Head press PSIG	161.5	164.4	167.3	170.4	173.7	177.2
	Cap. Btuh/1000	48.9	54.0	59.3	64.9	70.8	77.0
	OD Unit KW	3.4	3.4	3.5	3.7	3.8	3.9
85	Head press PSIG	186.8	189.9	193.0	196.3	199.8	203.4
	Cap. Btuh/1000	46.5	51.4	56.6	62.1	67.8	73.8
	OD Unit KW	3.7	3.7	3.8	4.0	4.1	4.2
95	Head press PSIG	214.8	218.1	221.4	225.0	228.6	232.3
	Cap. Btuh/1000	44.1	48.8	53.8	59.1	64.6	70.4
	OD Unit KW	4.0	4.1	4.2	4.3	4.4	4.6
105	Head press PSIG	245.6	249.1	252.7	256.4	260.2	264.2
	Cap. Btuh/1000	41.6	46.1	51.0	56.1	61.4	66.8
	OD Unit KW	4.4	4.5	4.6	4.7	4.9	5.0
115	Head press PSIG	279.4	283.0	286.8	290.7	294.7	298.9
	Cap. Btuh/1000	39.0	43.4	48.1	52.9	58.0	63.2
	OD Unit KW	4.9	5.0	5.1	5.2	5.3	5.5

Performance Data Calculated at 15 deg. subcooling and 15 deg. superheat.

Table PD-22 — Gross Cooling Capacities (kW) - Single Compressor - (SI)
TTA100C Condensing Unit Only

OD Temp °C		Suction Reference Temperature °C					
		-1.1	1.7	4.4	7.2	10.0	12.8
18.3	Head pressure (kPA)	956	974	994	1014	1035	1057
	Capacity (kW)	15.0	16.5	18.1	19.8	21.6	23.4
	OD Unit Power (kW)	3.13	3.21	3.30	3.39	3.50	3.62
23.9	Head pressure (kPA)	1114	1133	1154	1175	1198	1222
	Capacity (kW)	14.3	15.8	17.4	19.0	20.7	22.6
	OD Unit Power (kW)	3.36	3.45	3.54	3.65	3.77	3.89
29.4	Head pressure (kPA)	1288	1309	1331	1354	1378	1402
	Capacity (kW)	13.6	15.1	16.6	18.2	19.9	21.6
	OD Unit Power (kW)	3.65	3.74	3.85	3.96	4.08	4.21
35.0	Head pressure (kPA)	1481	1504	1527	1551	1576	1602
	Capacity (kW)	12.9	14.3	15.8	17.3	18.9	20.6
	OD Unit Power (kW)	4.01	4.10	4.20	4.32	4.44	4.58
40.6	Head pressure (kPA)	1694	1717	1742	1768	1794	1821
	Capacity (kW)	12.2	13.5	14.9	16.4	18.0	19.6
	OD Unit Power (kW)	4.42	4.51	4.62	4.73	4.86	5.00
46.1	Head pressure (kPA)	1926	1951	1977	2004	2032	2061
	Capacity (kW)	11.4	12.7	14.1	15.5	17.0	18.5
	OD Unit Power (kW)	4.89	4.98	5.08	5.20	5.32	5.46

Performance Data Calculated at 8.3 deg. subcooling and 8.3 deg. superheat.



Performance Data

Condensing Unit

Table PD-23 – Cooling Performance (MBh) TTA125B Condensing Unit Only (I-P)

ODTemp °F		Suction Reference Temperature °F					
		30	35	40	45	50	55
65	Head press PSIG	175	181	187	193	200	207
	Cap. Btuh/1000	116.6	128.0	139.9	152.2	164.9	178.1
	OD Unit KW	8.04	8.25	8.47	8.70	8.95	9.20
75	Head press PSIG	201	207	214	221	228	235
	Cap. Btuh/1000	111.2	122.1	133.4	145.2	157.5	170.0
	OD Unit KW	8.83	9.06	9.29	9.53	9.79	10.06
85	Head press PSIG	230	237	244	251	259	267
	Cap. Btuh/1000	105.6	116.0	126.9	138.1	149.8	161.8
	OD Unit KW	9.73	9.97	10.22	10.48	10.75	11.02
95	Head press PSIG	262	269	276	284	292	300
	Cap. Btuh/1000	99.9	109.7	120.0	130.8	141.8	153.2
	OD Unit KW	10.73	10.98	11.25	11.52	11.80	12.09
105	Head press PSIG	296	304	311	320	328	337
	Cap. Btuh/1000	94.0	103.2	113.0	123.1	133.6	144.5
	OD Unit KW	11.83	12.09	12.37	12.66	12.95	13.26
115	Head press PSIG	334	341	349	358	367	376
	Cap. Btuh/1000	87.9	96.6	105.7	115.2	125.2	135.5
	OD Unit KW	13.02	13.30	13.59	13.89	14.20	14.52

Performance Data Calculated at 15 deg. subcooling and 15 deg. superheat.

Table PD-23 – Cooling Performance (kW) TTA125B Condensing Unit Only (SI)

ODTemp °C		Suction Reference Temperature °C					
		-1.1	1.7	4.4	7.2	10.0	12.8
18.3	Head pressure (kPA)	1205	1245	1287	1331	1377	1425
	Capacity (kW)	34.1	37.5	41.0	44.6	48.3	52.1
	OD Unit Power (kW)	8.04	8.25	8.47	8.70	8.95	9.20
23.9	Head pressure (kPA)	1387	1430	1474	1521	1571	1623
	Capacity (kW)	32.6	35.8	39.1	42.5	46.1	49.8
	OD Unit Power (kW)	8.83	9.06	9.29	9.53	9.79	10.06
29.4	Head pressure (kPA)	1587	1633	1681	1731	1783	1838
	Capacity (kW)	30.9	34.0	37.2	40.4	43.9	47.4
	OD Unit Power (kW)	9.73	9.97	10.22	10.48	10.75	11.02
35.0	Head pressure (kPA)	1806	1855	1905	1958	2013	2071
	Capacity (kW)	29.2	32.1	35.2	38.3	41.5	44.9
	OD Unit Power (kW)	10.73	10.98	11.25	11.52	11.80	12.09
40.6	Head pressure (kPA)	2044	2095	2148	2203	2261	2322
	Capacity (kW)	27.5	30.2	33.1	36.0	39.1	42.3
	OD Unit Power (kW)	11.83	12.09	12.37	12.66	12.95	13.26
46.1	Head pressure (kPA)	2301	2354	2409	2466	2527	2591
	Capacity (kW)	25.7	28.3	30.9	33.7	36.7	39.7
	OD Unit Power (kW)	13.02	13.30	13.59	13.89	14.20	14.52

Performance Data Calculated at 8.3 deg. subcooling and 8.3 deg. superheat.



Performance Data

Condensing Unit

Table PD-24 – Cooling Performance (MBh) TTA155B Condensing Unit Only (I-P)

ODTemp		Suction Reference Temperature °F					
°F		30	35	40	45	50	55
65	Head press PSIG	171	178	185	192	200	208
	Cap. Btuh/1000	144.5	159.5	175.1	191.3	207.8	225.0
	OD Unit KW	9.84	10.10	10.37	10.67	11.00	11.35
75	Head press PSIG	197	204	211	218	227	235
	Cap. Btuh/1000	140.1	154.4	169.2	184.4	200.2	216.4
	OD Unit KW	10.85	11.13	11.43	11.74	12.09	12.45
85	Head press PSIG	225	232	239	247	256	265
	Cap. Btuh/1000	134.4	148.0	162.0	176.4	191.4	206.7
	OD Unit KW	12.02	12.32	12.64	12.97	13.32	13.70
95	Head press PSIG	255	263	270	278	287	297
	Cap. Btuh/1000	127.6	140.5	153.7	167.3	181.5	196.1
	OD Unit KW	13.38	13.68	14.00	14.33	14.70	15.08
105	Head press PSIG	288	296	303	312	321	331
	Cap. Btuh/1000	119.9	132.0	144.4	157.3	170.7	184.6
	OD Unit KW	14.89	15.19	15.50	15.83	16.19	16.58
115	Head press PSIG	323	331	339	347	357	367
	Cap. Btuh/1000	111.3	122.6	134.3	146.4	159.1	172.4
	OD Unit KW	16.56	16.84	17.14	17.45	17.81	18.20

Performance Data Calculated at 15 deg. subcooling and 15 deg. superheat.

Table PD-24 – Cooling Performance (kW) TTA155B Condensing Unit Only (SI)

ODTemp		Suction Reference Temperature °C					
°C		-1.1	1.7	4.4	7.2	10.0	12.8
18.3	Head pressure (kPA)	1180	1225	1273	1324	1378	1436
	Capacity (kW)	42.3	46.7	51.3	56.0	60.8	65.9
	OD Unit Power (kW)	9.84	10.10	10.37	10.67	11.00	11.35
23.9	Head pressure (kPA)	1357	1404	1454	1506	1563	1623
	Capacity (kW)	41.0	45.2	49.5	54.0	58.6	63.4
	OD Unit Power (kW)	10.85	11.13	11.43	11.74	12.09	12.45
29.4	Head pressure (kPA)	1550	1599	1651	1705	1764	1826
	Capacity (kW)	39.4	43.3	47.4	51.7	56.0	60.5
	OD Unit Power (kW)	12.02	12.32	12.64	12.97	13.32	13.70
35.0	Head pressure (kPA)	1760	1811	1864	1920	1981	2045
	Capacity (kW)	37.4	41.1	45.0	49.0	53.1	57.4
	OD Unit Power (kW)	13.38	13.68	14.00	14.33	14.70	15.08
40.6	Head pressure (kPA)	1986	2038	2093	2150	2213	2280
	Capacity (kW)	35.1	38.6	42.3	46.0	50.0	54.1
	OD Unit Power (kW)	14.89	15.19	15.50	15.83	16.19	16.58
46.1	Head pressure (kPA)	2228	2282	2337	2396	2461	2530
	Capacity (kW)	32.6	35.9	39.3	42.9	46.6	50.5
	OD Unit Power (kW)	16.56	16.84	17.14	17.45	17.81	18.20

Performance Data Calculated at 8.3 deg. subcooling and 8.3 deg. superheat.



Performance Data

Condensing Unit

Table PD-25 — Gross Cooling Capacities (MBh) - Both Compressors - (I-P)
TTA155C Condensing Unit Only

ODTemp		Suction Reference Temperature °F					
°F		30	35	40	45	50	55
65	Head press. PSIG	169.8	176.2	183.0	190.1	197.8	206.0
	Cap. Btuh/1000	144.3	159.3	175.0	191.1	207.7	224.9
	OD Unit KW	9.8	10.0	10.3	10.6	10.9	11.3
75	Head press. PSIG	195.5	202.2	209.2	216.8	224.9	233.4
	Cap. Btuh/1000	140.0	154.3	169.1	184.4	200.2	216.4
	OD Unit KW	10.8	11.1	11.4	11.7	12.0	12.4
85	Head press. PSIG	223.5	230.5	237.9	245.9	254.3	263.0
	Cap. Btuh/1000	134.2	147.9	161.9	176.5	191.4	206.8
	OD Unit KW	12.0	12.3	12.6	12.9	13.3	13.6
95	Head press. PSIG	253.9	261.2	269.0	277.2	285.9	294.9
	Cap. Btuh/1000	127.5	140.3	153.7	167.4	181.6	196.2
	OD Unit KW	13.3	13.6	13.9	14.3	14.6	15.0
105	Head press. PSIG	286.6	294.1	302.2	310.8	319.8	329.0
	Cap. Btuh/1000	119.7	131.8	144.3	157.3	170.8	184.6
	OD Unit KW	14.8	15.1	15.4	15.8	16.1	16.5
115	Head press. PSIG	321.6	329.3	337.7	346.5	355.9	365.5
	Cap. Btuh/1000	111.1	122.4	134.2	146.5	159.2	172.4
	OD Unit KW	16.5	16.8	17.1	17.4	17.8	18.1

Performance Data Calculated at 15 deg. subcooling and 15 deg. superheat.

Table PD-25 — Gross Cooling Capacities (kW) - Both Compressors - (SI)
TTA155C Condensing Unit Only

ODTemp		Suction Reference Temperature °C					
°C		-1.1	1.7	4.4	7.2	10.0	12.8
18.3	Head pressure (kPA)	1171	1215	1262	1311	1364	1421
	Capacity (kW)	42.3	46.6	51.2	56.0	60.8	65.9
	OD Unit Power (kW)	9.79	10.04	10.31	10.60	10.92	11.26
23.9	Head pressure (kPA)	1348	1394	1443	1495	1551	1609
	Capacity (kW)	41.0	45.2	49.5	54.0	58.6	63.4
	OD Unit Power (kW)	10.79	11.07	11.36	11.68	12.02	12.37
29.4	Head pressure (kPA)	1541	1589	1640	1695	1753	1813
	Capacity (kW)	39.3	43.3	47.4	51.7	56.1	60.5
	OD Unit Power (kW)	11.97	12.26	12.57	12.91	13.26	13.62
35.0	Head pressure (kPA)	1751	1801	1854	1911	1971	2034
	Capacity (kW)	37.3	41.1	45.0	49.0	53.2	57.4
	OD Unit Power (kW)	13.32	13.62	13.94	14.28	14.63	15.01
40.6	Head pressure (kPA)	1976	2028	2084	2143	2205	2269
	Capacity (kW)	35.0	38.6	42.3	46.1	50.0	54.0
	OD Unit Power (kW)	14.83	15.12	15.44	15.78	16.14	16.51
46.1	Head pressure (kPA)	2217	2270	2328	2389	2454	2520
	Capacity (kW)	32.5	35.8	39.3	42.9	46.6	50.5
	OD Unit Power (kW)	16.49	16.77	17.08	17.41	17.77	18.14

Performance Data Calculated at 8.3 deg. subcooling and 8.3 deg. superheat.



Performance Data

Condensing Unit

Table PD-26 — Cooling Performance (MBh) - Single Compressor - (I-P)
TTA155C Condensing Unit Only

ODTemp		Suction Reference Temperature °F					
°F		30	35	40	45	50	55
65	Head press. PSIG	139.0	141.9	145.1	148.5	152.1	155.9
	Cap. Btuh/1000	71.8	79.5	87.9	96.8	106.2	116.1
	OD Unit KW	4.9	4.9	5.0	5.1	5.1	5.2
75	Head press. PSIG	163.0	166.2	169.6	173.1	176.9	180.8
	Cap. Btuh/1000	70.8	78.4	86.5	95.1	104.0	113.3
	OD Unit KW	5.3	5.3	5.4	5.5	5.6	5.7
85	Head press. PSIG	189.4	192.8	196.4	200.1	204.0	208.0
	Cap. Btuh/1000	68.9	76.4	84.2	92.4	100.9	109.6
	OD Unit KW	5.8	5.9	5.9	6.0	6.1	6.2
95	Head press. PSIG	218.1	221.8	225.6	229.5	233.6	237.8
	Cap. Btuh/1000	66.3	73.5	81.0	88.8	96.9	105.3
	OD Unit KW	6.4	6.5	6.5	6.6	6.7	6.8
105	Head press. PSIG	249.6	253.5	257.5	261.6	265.9	270.3
	Cap. Btuh/1000	63.0	69.9	77.1	84.5	92.3	100.3
	OD Unit KW	7.1	7.2	7.2	7.3	7.4	7.5
115	Head press. PSIG	283.6	287.8	292.0	296.3	300.8	305.5
	Cap. Btuh/1000	59.1	65.6	72.5	79.6	87.0	94.7
	OD Unit KW	7.9	7.9	8.0	8.1	8.2	8.2

Performance Data Calculated at 15 deg. subcooling and 15 deg. superheat.

Table PD-26 — Cooling Performance (kW) - Single Compressor - (SI)
TTA155C Condensing Unit Only

ODTemp		Suction Reference Temperature °C					
°C		-1.1	1.7	4.4	7.2	10.0	12.8
18.3	Head pressure (kPa)	959	979	1000	1024	1049	1075
	Capacity (kW)	21.0	23.3	25.7	28.3	31.1	34.0
	OD Unit Power (kW)	4.89	4.93	4.99	5.06	5.13	5.21
23.9	Head pressure (kPa)	1124	1146	1169	1194	1220	1246
	Capacity (kW)	20.7	23.0	25.3	27.8	30.5	33.2
	OD Unit Power (kW)	5.29	5.35	5.42	5.49	5.57	5.66
29.4	Head pressure (kPa)	1306	1329	1354	1380	1406	1434
	Capacity (kW)	20.2	22.4	24.7	27.0	29.5	32.1
	OD Unit Power (kW)	5.79	5.86	5.93	6.01	6.10	6.18
35.0	Head pressure (kPa)	1504	1529	1555	1583	1611	1640
	Capacity (kW)	19.4	21.5	23.7	26.0	28.4	30.8
	OD Unit Power (kW)	6.38	6.46	6.54	6.62	6.70	6.79
40.6	Head pressure (kPa)	1721	1748	1775	1804	1833	1864
	Capacity (kW)	18.4	20.5	22.6	24.7	27.0	29.4
	OD Unit Power (kW)	7.08	7.15	7.23	7.31	7.39	7.48
46.1	Head pressure (kPa)	1956	1984	2013	2043	2074	2107
	Capacity (kW)	17.3	19.2	21.2	23.3	25.5	27.7
	OD Unit Power (kW)	7.86	7.93	8.00	8.08	8.16	8.25

Performance Data Calculated at 8.3 deg. subcooling and 8.3 deg. superheat.



Performance Data

Condensing Unit

Table PD-27 — Cooling Capacities (MBh) TTA200B Condensing Unit Only (I-P)

ODTemp °F		Suction Reference Temperature °F					
		30	35	40	45	50	55
65	Head press PSIG	168	174	180	186	193	200
	Cap. Btuh/1000	198.0	217.3	237.4	258.3	280.0	302.5
	OD Unit KW	12.47	12.77	13.08	13.42	13.79	14.18
75	Head press PSIG	194	200	206	213	220	227
	Cap. Btuh/1000	188.9	207.0	226.1	245.9	266.6	288.2
	OD Unit KW	13.83	14.16	14.50	14.88	15.28	15.71
85	Head press PSIG	222	228	235	242	249	257
	Cap. Btuh/1000	179.1	196.3	214.4	233.4	253.2	273.7
	OD Unit KW	15.45	15.80	16.19	16.59	17.03	17.48
95	Head press PSIG	253	259	266	274	282	290
	Cap. Btuh/1000	168.7	185.1	202.5	220.6	239.6	259.2
	OD Unit KW	17.31	17.70	18.12	18.56	19.02	19.50
105	Head press PSIG	286	293	301	309	317	326
	Cap. Btuh/1000	157.8	173.7	190.3	207.7	225.9	244.6
	OD Unit KW	19.42	19.85	20.31	20.78	21.26	21.75
115	Head press PSIG	321	329	337	346	355	364
	Cap. Btuh/1000	146.5	161.9	177.9	194.7	212.0	229.8
	OD Unit KW	21.75	22.23	22.73	23.23	23.74	24.23

Performance Data Calculated at 15 deg. subcooling and 15 deg. superheat.

Table PD-27 — Cooling Capacities (MBh) TTA200B Condensing Unit Only (SI)

ODTemp °C		Suction Reference Temperature °C					
		-1.1	1.7	4.4	7.2	10.0	12.8
18.3	Head pressure (kPa)	1159	1198	1239	1282	1327	1376
	Capacity (kW)	58.0	63.6	69.5	75.6	82.0	88.6
	OD Unit Power (kW)	12.47	12.77	13.08	13.42	13.79	14.18
23.9	Head pressure (kPa)	1336	1377	1420	1466	1514	1565
	Capacity (kW)	55.3	60.6	66.2	72.0	78.1	84.4
	OD Unit Power (kW)	13.83	14.16	14.50	14.88	15.28	15.71
29.4	Head pressure (kPa)	1530	1573	1619	1668	1719	1773
	Capacity (kW)	52.4	57.5	62.8	68.3	74.1	80.1
	OD Unit Power (kW)	15.45	15.80	16.19	16.59	17.03	17.48
35.0	Head pressure (kPa)	1741	1788	1836	1888	1943	2000
	Capacity (kW)	49.4	54.2	59.3	64.6	70.1	75.9
	OD Unit Power (kW)	17.31	17.70	18.12	18.56	19.02	19.50
40.6	Head pressure (kPa)	1970	2020	2072	2128	2185	2246
	Capacity (kW)	46.2	50.8	55.7	60.8	66.1	71.6
	OD Unit Power (kW)	19.42	19.85	20.31	20.78	21.26	21.75
46.1	Head pressure (kPa)	2216	2270	2327	2386	2448	2511
	Capacity (kW)	42.9	47.4	52.1	57.0	62.1	67.3
	OD Unit Power (kW)	21.75	22.23	22.73	23.23	23.74	24.23

Performance Data Calculated at 8.3 deg. subcooling and 8.3 deg. superheat.



Performance Data

Condensing Unit

Table PD28: Gross Cooling Capacities (MBH) - 20 Ton TTA200F Condensing Unit Only (I-P)

Outdoor Air Temperature (F)		Saturated Suction Temperature (F)					
		30	35	40	45	50	55
65	Head Pressure (psig)	292.4	302.4	313.1	324.4	336.3	348.8
	Capacity (MBH)	208.2	227.3	247.1	267.6	288.8	310.5
	Unit KW	11.40	11.73	12.08	12.45	12.84	13.25
75	Head Pressure (psig)	331.2	341.8	353.0	364.7	377.1	390.0
	Capacity (MBH)	196.0	214.2	233.2	252.7	272.9	293.5
	Unit KW	12.59	12.94	13.31	13.70	14.11	14.54
85	Head Pressure (psig)	373.3	384.3	396.0	408.2	420.9	434.3
	Capacity (MBH)	182.9	200.3	218.2	236.8	255.9	275.4
	Unit KW	13.99	14.36	14.75	15.16	15.58	16.02
95	Head Pressure (psig)	418.7	430.2	442.3	454.9	468.0	481.7
	Capacity (MBH)	169.2	185.6	202.6	220.0	238.0	256.4
	Unit KW	15.61	15.99	16.39	16.81	17.24	17.68
105	Head Pressure (psig)	467.6	479.4	491.8	504.7	518.1	531.9
	Capacity (MBH)	154.9	170.3	186.1	202.5	219.3	236.4
	Unit KW	17.43	17.82	18.22	18.64	19.07	19.50
115	Head Pressure (psig)	519.7	531.8	544.5	557.5	570.9	584.6
	Capacity (MBH)	140.1	154.3	169.0	184.1	199.6	215.3
	Unit KW	19.43	19.83	20.23	20.64	21.05	21.46

Table PD-28: Gross Cooling Capacities (MBH) - 20 Ton TTA200F Condensing Unit Only (SI)

Outdoor Air Temperature (C)		Saturated Suction Temperature (C)					
		-1.1	1.7	4.4	7.2	10.0	12.8
18.3	Head Pressure (kPA)	2015.8	2085.1	2158.9	2236.8	2318.7	2404.7
	Capacity (KW)	61.0	66.6	72.4	78.4	84.6	91.0
	Unit KW	11.40	11.73	12.08	12.45	12.84	13.25
23.9	Head Pressure (kPA)	2283.6	2356.5	2433.7	2514.9	2599.9	2688.8
	Capacity (KW)	57.4	62.8	68.3	74.1	80.0	86.0
	Unit KW	12.59	12.94	13.31	13.70	14.11	14.54
29.4	Head Pressure (kPA)	2573.7	2649.8	2730.1	2814.2	2902.2	2994.2
	Capacity (KW)	53.6	58.7	64.0	69.4	75.0	80.7
	Unit KW	13.99	14.36	14.75	15.16	15.58	16.02
35.0	Head Pressure (kPA)	2886.7	2966.0	3049.5	3136.4	3227.0	3321.0
	Capacity (KW)	49.6	54.4	59.4	64.5	69.8	75.1
	Unit KW	15.61	15.99	16.39	16.81	17.24	17.68
40.6	Head Pressure (kPA)	3223.7	3305.5	3391.1	3480.0	3572.4	3667.6
	Capacity (KW)	45.4	49.9	54.6	59.3	64.3	69.3
	Unit KW	17.43	17.82	18.22	18.64	19.07	19.50
46.1	Head Pressure (kPA)	3583.3	3666.9	3754.0	3843.8	3936.2	4030.5
	Capacity (KW)	41.1	45.2	49.5	54.0	58.5	63.1
	Unit KW	19.43	19.83	20.23	20.64	21.05	21.46



Performance Data

Air Handler

Table PD-29— Evaporator Fan Performance — TWE050A (I-P)

CFM	External Static Pressure (Inches of Water Column)																							
	.10"		.20"		.30"		.40"		.50"		.60"		.70"		.80"		.90"		1.00"		1.10"			
	RPM	BHP	RPM	BHP	RPM	BHP	RPM	BHP	RPM	BHP	RPM	BHP	RPM	BHP	RPM	BHP	RPM	BHP	RPM	BHP	RPM	BHP	RPM	BHP
1400	—	—	—	—	646	0.37	698	0.42	751	0.47	803	0.52	856	0.56	908	0.61	941	0.65	973	0.68	1006	0.71	—	—
1500	—	—	607	0.36	661	0.40	713	0.45	764	0.50	816	0.54	867	0.59	919	0.64	952	0.67	984	0.71	—	—	—	—
1600	—	—	625	0.38	676	0.43	727	0.48	778	0.52	828	0.57	879	0.62	930	0.67	963	0.70	995	0.74	—	—	—	—
1700	601	0.35	648	0.40	696	0.44	744	0.49	792	0.54	841	0.59	889	0.64	937	0.69	971	0.73	1005	0.77	—	—	—	—
1800	625	0.36	671	0.41	716	0.46	762	0.51	807	0.56	853	0.61	898	0.66	944	0.71	979	0.76	—	—	—	—	—	—
1900	642	0.40	687	0.45	731	0.50	776	0.55	820	0.60	865	0.66	909	0.71	951	0.75	987	0.80	—	—	—	—	—	—
2000	659	0.44	703	0.49	745	0.54	790	0.60	833	0.65	877	0.70	920	0.75	957	0.80	994	0.84	—	—	—	—	—	—
2100	674	0.48	722	0.54	770	0.60	817	0.65	857	0.70	897	0.75	936	0.80	973	0.85	1009	0.89	—	—	—	—	—	—
	0.75 HP Standard Motor and Standard Static Drive									1.0 HP Oversized Motor and High Static Drive														

Notes:

1. Performance based on a wet coil and 1 inch (25.4 mm) throwaway filters.
2. Tabulated brake horsepower is the motor shaft output required.
3. Factory setting of motor sheave is 1.5 turns open. Adjustments are made in 0.5 turn increments.

Table PD-29— Evaporator Fan Performance — TWE050A (SI)

m ³ /hr	External Static Pressure (Pascal)																							
	25		50		75		100		125		150		174		199		224		249		274			
	RPM	kW	RPM	kW	RPM	kW	RPM	kW	RPM	kW	RPM	kW	RPM	kW	RPM	kW	RPM	kW	RPM	kW	RPM	kW	RPM	kW
2379	—	—	—	—	646	0.28	698	0.31	751	0.35	803	0.39	856	0.42	908	0.45	941	0.48	973	0.51	1006	0.53	—	—
2549	—	—	607	0.27	661	0.30	713	0.34	764	0.37	816	0.40	867	0.44	919	0.48	952	0.50	984	0.53	—	—	—	—
2718	—	—	625	0.28	676	0.32	727	0.36	778	0.39	828	0.43	879	0.46	930	0.50	963	0.52	995	0.55	—	—	—	—
2888	601	0.26	648	0.30	696	0.33	744	0.37	792	0.40	841	0.44	889	0.48	937	0.51	971	0.54	1005	0.57	—	—	—	—
3058	625	0.27	671	0.31	716	0.34	762	0.38	807	0.42	853	0.45	898	0.49	944	0.53	979	0.57	—	—	—	—	—	—
3228	642	0.30	687	0.34	731	0.37	776	0.41	820	0.45	865	0.49	909	0.53	951	0.56	987	0.60	—	—	—	—	—	—
3398	659	0.33	703	0.37	745	0.40	790	0.45	833	0.48	877	0.52	920	0.56	957	0.60	994	0.63	—	—	—	—	—	—
3568	674	0.36	722	0.40	770	0.45	817	0.48	857	0.52	897	0.56	936	0.60	973	0.63	1009	0.66	—	—	—	—	—	—
	0.56 kW Standard Motor and Standard Static Drive									0.75 kW Oversized Motor and High Static Drive														

Notes:

1. Performance based on a wet coil and 1 inch (25.4 mm) throwaway filters.
2. Tabulated brake horsepower is the motor shaft output required.
3. Factory setting of motor sheave is 1.5 turns open. Adjustments are made in 0.5 turn increments.

Table PD-30— Blower Speeds — TWE050A

Drive	Motor Drive Turns Open						
	6	5	4	3	2	1	0
Standard	N/A	590	639	688	737	786	835
High Static	N/A	713	772	832	891	951	1009



Performance Data

Air Handler

Table PD-31 – Evaporator Fan Performance TWE075A (I-P)

CFM	External Static Pressure (In. Of Water Column)																					
	0.10		0.20		0.30		0.40		0.50		0.60		0.70		0.80		0.90		1.00		1.10	
	RPM	BHP	RPM	BHP	RPM	BHP	RPM	BHP	RPM	BHP	RPM	BHP	RPM	BHP	RPM	BHP	RPM	BHP	RPM	BHP	RPM	BHP
2000	—	—	443	0.44	489	0.49	535	0.54	581	0.59	627	0.64	673	0.69	719	0.74	765	0.79	791	0.83	818	0.89
2125	—	—	453	0.46	499	0.52	546	0.57	592	0.63	638	0.68	684	0.74	730	0.79	771	0.85	798	0.90	825	0.96
2250	—	—	463	0.49	510	0.55	556	0.61	602	0.67	649	0.73	695	0.79	742	0.85	776	0.91	804	0.97	831	1.03
2375	—	—	473	0.51	520	0.57	567	0.64	613	0.70	660	0.77	706	0.83	753	0.90	782	0.97	810	1.03	838	1.10
2500	445	0.47	489	0.54	533	0.60	578	0.67	622	0.73	667	0.80	711	0.86	756	0.93	784	0.99	813	1.07	842	1.14
2625	464	0.50	506	0.57	548	0.63	589	0.69	631	0.76	672	0.82	714	0.88	757	0.95	786	1.01	815	1.09	844	1.17
2750	484	0.53	523	0.59	562	0.66	601	0.72	640	0.78	678	0.84	717	0.91	758	0.97	787	1.03	817	1.12	847	1.21
2875	504	0.56	540	0.62	576	0.68	612	0.74	648	0.81	684	0.87	720	0.93	759	0.99	789	1.05	819	1.15	850	1.24
3000	524	0.59	557	0.65	590	0.71	624	0.77	657	0.83	690	0.89	723	0.95	760	1.01	790	1.07	821	1.17	853	1.27
	1.0 HP Standard Motor and Low Static Drive							1.0 HP Standard Motor and Drive							1.5 HP Oversized Motor and High Static Drive							

Notes:

- Performance based on a wet coil and 1 inch (25.4 mm) throwaway filters.
- Tabulated brake horsepower is the motor shaft output required.
- Factory setting of motor sheave is 1.5 turns open. Adjustments are made in 0.5 turn increments.

Table PD-29 – Continued

CFM	External Static Pressure (In. Of Water Column)									
	1.20		1.30		1.40		1.50		1.60	
	RPM	BHP	RPM	BHP	RPM	BHP	RPM	BHP	RPM	BHP
2000	844	0.96	871	1.02	897	1.09	924	1.15	950	1.21
2125	852	1.03	879	1.09	906	1.16	933	1.22	—	—
2250	859	1.10	886	1.17	914	1.23	942	1.30	—	—
2375	866	1.17	894	1.24	922	1.30	950	1.37	—	—
2500	870	1.21	899	1.29	928	1.36	—	—	—	—
2625	874	1.25	903	1.33	932	1.42	—	—	—	—
2750	877	1.29	907	1.38	937	1.47	—	—	—	—
2875	880	1.33	911	1.43	942	1.52	—	—	—	—
3000	884	1.37	915	1.48	946	1.58	—	—	—	—
	1.5 HP Oversized Motor and High Static Drive									

1.0 HP Standard Motor and Drive

Table PD-31 – Evaporator Fan Performance TWE075A (SI)

m³/hr	External Static Pressure (Pascal)																						
	25		50		75		100		125		150		174		199		224		249		274		
	RPM	kW	RPM	kW	RPM	kW	RPM	kW	RPM	kW	RPM	kW	RPM	kW	RPM	kW	RPM	kW	RPM	kW	RPM	kW	RPM
3338	—	—	443	0.33	489	0.37	535	0.4	581	0.44	627	0.48	673	0.51	719	0.55	765	0.59	791	0.62	818	0.66	
3547	—	—	453	0.34	499	0.39	546	0.43	592	0.47	638	0.51	684	0.55	730	0.59	771	0.63	798	0.67	825	0.72	
3755	—	—	463	0.37	510	0.41	556	0.45	602	0.5	649	0.54	695	0.59	742	0.63	776	0.68	804	0.72	831	0.77	
3964	—	—	473	0.38	520	0.43	567	0.48	613	0.52	660	0.57	706	0.62	753	0.67	782	0.72	810	0.77	838	0.82	
4173	445	0.35	489	0.4	533	0.45	578	0.5	622	0.54	667	0.6	711	0.64	756	0.69	784	0.74	813	0.8	842	0.85	
4381	464	0.37	506	0.43	548	0.47	589	0.51	631	0.57	672	0.61	714	0.66	757	0.71	786	0.75	815	0.81	844	0.87	
4590	484	0.4	523	0.44	562	0.49	601	0.54	640	0.58	678	0.63	717	0.68	758	0.72	787	0.77	817	0.84	847	0.9	
4798	504	0.42	540	0.46	576	0.51	612	0.55	648	0.6	684	0.65	720	0.69	759	0.74	789	0.78	819	0.86	850	0.92	
5007	524	0.44	557	0.48	590	0.53	624	0.57	657	0.62	690	0.66	723	0.71	760	0.75	790	0.8	821	0.87	853	0.95	
	.75 kW Standard Motor and Low Static Drive							.75 kW Standard Motor and Drive							1.12 kW Oversized Motor and High Static Drive								

Notes:

- Performance based on a wet coil and 1 inch (25.4 mm) throwaway filters.
- Tabulated brake horsepower is the motor shaft output required.
- Factory setting of motor sheave is 1.5 turns open. Adjustments are made in 0.5 turn increments.

Table PD-31 – Continued

m³/hr	External Static Pressure (Pascal)									
	299		324		349		374		398	
	RPM	kW	RPM	kW	RPM	kW	RPM	kW	RPM	kW
3338	844	0.72	871	0.76	897	0.81	924	0.86	950	0.9
3547	852	0.77	879	0.81	906	0.87	933	0.91	—	—
3755	859	0.82	886	0.87	914	0.92	942	0.97	—	—
3964	866	0.87	894	0.92	922	0.97	950	1.02	—	—
4173	870	0.9	899	0.96	928	1.01	—	—	—	—
4381	874	0.93	903	0.99	932	1.06	—	—	—	—
4590	877	0.96	907	1.03	937	1.1	—	—	—	—
4798	880	0.99	911	1.07	942	1.13	—	—	—	—
5007	884	1.02	915	1.1	946	1.18	—	—	—	—
	1.12 kW Oversized Motor and High Static Drive									

.75 kW Standard Motor and Drive

Table PD-32 – Blower Speeds – TWE075A

Drive	Motor Drive Turns Open						
	6	5	4	3	2	1	0
Standard	N/A	600	650	700	750	800	850
Low Static	N/A	428	464	499	535	571	606
High Static	N/A	700	750	800	850	900	950



Performance Data

Air Handler

Table PD-33 – Evaporator Fan Performance TWE100A, TWE100B (I-P)

CFM	External Static Pressure (In. Of Water Column)																							
	0.10		0.20		0.30		0.40		0.50		0.60		0.70		0.80		0.90		1.00		1.20			
	RPM	BHP	RPM	BHP	RPM	BHP	RPM	BHP	RPM	BHP	RPM	BHP	RPM	BHP	RPM	BHP	RPM	BHP	RPM	BHP	RPM	BHP	RPM	BHP
1.5 HP Standard Motor and Low Static Drive																								
2600	460	0.32	493	0.39	527	0.47	565	0.55	603	0.63	641	0.71	679	0.79	717	0.87	744	0.94	772	1.01	826	1.16		
2775	473	0.37	506	0.45	540	0.53	576	0.61	613	0.69	649	0.77	686	0.85	723	0.93	748	1.00	775	1.07	830	1.20		
2950	487	0.43	519	0.50	552	0.58	587	0.67	623	0.75	658	0.83	693	0.91	728	0.99	751	1.06	779	1.12	833	1.25		
3125	501	0.49	532	0.56	565	0.64	599	0.72	632	0.81	666	0.89	700	0.97	734	1.05	755	1.11	783	1.18	737	1.30		
3300	520	0.58	548	0.65	581	0.73	613	0.81	644	0.89	677	0.98	710	1.06	740	1.13	759	1.19	787	1.25	841	1.37		
3475	541	0.69	568	0.76	600	0.84	631	0.93	658	1.00	691	1.08	721	1.16	746	1.21	764	1.28	793	1.34	846	1.48		
3650	562	0.82	588	0.88	618	0.97	648	1.05	671	1.11	703	1.19	732	1.27	753	1.31	772	1.38	801	1.45	853	1.59		
3825	582	0.96	608	1.03	637	1.11	666	1.20	685	1.26	711	1.31	739	1.38	763	1.44	787	1.51	815	1.58	862	1.74		
4000	602	1.11	628	1.17	656	1.26	683	1.35	698	1.40	720	1.43	747	1.50	773	1.58	801	1.64	829	1.71	872	1.89		
1.5 HP Standard Motor and Drive																	2.0 HP Oversized Motor and High Static Drive							

Notes:

1. Performance based on a wet coil and 1 inch (25.4 mm) throwaway filters.
2. Tabulated brake horsepower is the motor shaft output required.
3. Factory setting of motor sheave is 1.5 turns open. Adjustments are made in 0.5 turn increments.
4. Low Static Drive must be field supplied.

Table PD-33— Continued

CFM	External Static Pressure (In. Of Water Column)			
	1.40		1.60	
	RPM	BHP	RPM	BHP
2.0 HP Oversized Motor and High Static Drive				
2600	881	1.30	936	1.45
2775	884	1.36	938	1.51
2960	886	1.41	939	1.57
3125	889	1.47	941	1.64
3300	892	1.54	945	1.73
3475	897	1.63	950	1.85
3650	902	1.73	955	1.99
3825	912	1.89	960	2.18
4000	922	2.04	965	2.30

Table PD-33— Evaporator Fan Performance TWE0100A, TWE100B (SI)

m³/hr	External Static Pressure (Pascal)																							
	25		50		75		100		125		150		174		199		224		249		299			
	RPM	kW	RPM	kW	RPM	kW	RPM	kW	RPM	kW	RPM	kW	RPM	kW	RPM	kW	RPM	kW	RPM	kW	RPM	kW	RPM	kW
1.12 kW Standard Motor and Low Static Drive																								
4417	460	0.24	493	0.29	527	0.35	565	0.41	603	0.47	641	0.53	679	0.59	717	0.65	744	0.7	772	0.75	826	0.87		
4715	473	0.28	506	0.34	540	0.4	576	0.45	613	0.51	649	0.57	686	0.63	723	0.69	748	0.75	775	0.8	830	0.89		
5012	487	0.32	519	0.37	552	0.43	587	0.5	623	0.56	658	0.62	693	0.68	728	0.74	751	0.79	779	0.84	833	0.93		
5309	501	0.37	532	0.42	565	0.48	599	0.54	632	0.6	666	0.66	700	0.72	734	0.78	755	0.83	783	0.88	737	0.97		
5607	520	0.43	548	0.48	581	0.54	613	0.6	644	0.66	677	0.73	710	0.79	740	0.84	759	0.89	787	0.93	841	1.02		
5904	541	0.51	568	0.57	600	0.63	631	0.69	658	0.75	691	0.8	721	0.87	746	0.9	764	0.95	793	1	846	1.1		
6201	562	0.61	588	0.66	618	0.72	648	0.78	671	0.83	703	0.89	732	0.95	753	0.98	772	1.03	801	1.08	853	1.19		
6499	582	0.72	608	0.77	637	0.83	666	0.89	685	0.94	711	0.98	739	1.03	763	1.07	787	1.13	815	1.18	862	1.3		
6796	602	0.83	628	0.87	656	0.94	683	1.01	698	1.04	720	1.07	747	1.12	773	1.18	801	1.22	829	1.28	872	1.41		
1.12 kW Standard Motor and Drive																	1.49 kW Oversized Motor and High Static Drive							

Notes:

1. Performance based on a wet coil and 1 inch (25.4 mm) throwaway filters.
2. Tabulated brake horsepower is the motor shaft output required.
3. Factory setting of motor sheave is 3.0 turns open. Adjustments are made in 0.5 turn increments.
4. Low Static Drive must be field supplied.

Table PD-33— Continued

m³/hr	External Static Pressure (Pascal)			
	349		398	
	RPM	kW	RPM	kW
1.49 kW Oversized Motor and High Static Drive				
4417	881	0.97	936	1.08
4715	884	1.01	938	1.13
5012	886	1.05	939	1.17
5309	889	1.1	941	1.22
5607	892	1.15	945	1.29
5904	897	1.22	950	1.38
6201	902	1.29	955	1.48
6499	912	1.41	960	1.63
6796	922	1.52	965	1.72

Table PD-34 – Blower Speeds – TWE100A, TWE100B

Drive	Motor Sheave Turns Open						
	6	5	4	3	2	1	0
Standard	N/A	587	629	671	713	755	796
Low Static	N/A	453	485	518	550	583	615
High Static	N/A	606	641	677	713	748	784
High Static II	N/A	745	789	833	877	920	965



Performance Data

Air Handler

Table PD-35 – Evaporator Fan Performance – TWE155B (I-P)

		External Static Pressure (Inches of Water Column)																									
		.10"		.20"		.30"		.40"		.50"		.60"		.70"		.80"		.90"		1.00"		1.20"		1.40"			
CFM		RPM	BHP	RPM	BHP	RPM	BHP	RPM	BHP	RPM	BHP	RPM	BHP	RPM	BHP	RPM	BHP	RPM	BHP	RPM	BHP	RPM	BHP	RPM	BHP		
												2.0 HP Standard Motor and Drive												3.0 HP Oversized Motor and High Static Drive			
4000	628	1.34	653	1.38	678	1.43	692	1.48	708	1.52	723	1.57	738	1.60	749	1.61	759	1.62	775	1.66	806	1.71	851	1.85	907	2.03	
4250	633	1.37	658	1.41	683	1.46	697	1.51	713	1.55	728	1.60	743	1.62	751	1.63	770	1.64	782	1.67	817	1.76	873	1.96	929	2.19	
4500	637	1.40	662	1.44	687	1.49	701	1.53	717	1.58	732	1.63	747	1.64	754	1.65	782	1.67	793	1.72	828	1.81	884	2.01	940	2.27	
4750	641	1.42	666	1.50	691	1.53	705	1.61	721	1.63	736	1.65	751	1.66	765	1.67	793	1.72	804	1.92	832	2.03	861	2.15	920	2.44	
5000	645	1.44	670	1.52	695	1.56	710	1.65	725	1.67	739	1.68	758	1.70	777	1.74	806	1.81	839	1.91	896	2.13	—	—	—	—	
5260	650	1.46	675	1.53	700	1.59	716	1.67	728	1.70	741	1.73	765	1.75	790	1.82	819	1.92	849	2.03	907	2.28	—	—	—	—	
5500	652	1.47	678	1.55	703	1.63	721	1.71	734	1.75	747	1.78	775	1.83	804	1.92	832	2.03	861	2.15	920	2.44	—	—	—	—	
5750	653	1.48	680	1.57	706	1.68	726	1.76	743	1.81	761	1.86	789	1.94	817	2.04	846	2.16	875	2.29	935	2.61	—	—	—	—	
6000	655	1.49	681	1.59	709	1.74	731	1.80	752	1.87	774	1.94	803	2.05	831	2.17	860	2.29	889	2.44	950	2.78	—	—	—	—	

Notes:

1. Performance based on a wet coil and 2 inch (51 mm) throwaway filters.
2. Tabulated brake horsepower is the motor shaft output required.
3. Factory setting of motor sheave is 1.5 turns open. Adjustments are made in 0.5 turn increments.

Table PD-35 – Evaporator Fan Performance TWE155B (SI)

		External Static Pressure (Pascal)																									
		25		50		75		100		125		150		174		199		224		249		299		349			
m ³ /hr		RPM	kW	RPM	kW	RPM	kW	RPM	kW	RPM	kW	RPM	kW	RPM	kW	RPM	kW	RPM	kW	RPM	kW	RPM	kW	RPM	kW		
												1.49 kW Standard Motor and Drive												2.24 kW Oversized Motor and High Static Drive			
6796	628	1	653	1.03	678	1.07	692	1.1	708	1.13	723	1.17	738	1.19	749	1.2	759	1.21	775	1.24	806	1.28	851	1.38	907	1.51	
7221	633	1.02	658	1.05	683	1.09	697	1.13	713	1.16	728	1.19	743	1.21	751	1.22	770	1.22	782	1.25	817	1.31	873	1.46	929	1.63	
7646	637	1.04	662	1.07	687	1.11	701	1.14	717	1.18	732	1.22	747	1.23	754	1.23	782	1.25	793	1.28	828	1.35	884	1.5	940	1.69	
8070	641	1.06	666	1.12	691	1.14	705	1.2	721	1.22	736	1.23	751	1.24	765	1.25	793	1.28	804	1.43	832	1.51	861	1.6	920	1.82	
8495	645	1.07	670	1.13	695	1.16	710	1.23	725	1.25	739	1.25	758	1.27	777	1.3	806	1.35	839	1.42	896	1.59	—	—	—	—	
8937	650	1.09	675	1.14	700	1.19	716	1.25	728	1.27	741	1.29	765	1.3	790	1.36	819	1.43	849	1.51	907	1.7	—	—	—	—	
9345	652	1.1	678	1.16	703	1.22	721	1.28	734	1.3	747	1.33	775	1.36	804	1.43	832	1.51	861	1.6	920	1.82	—	—	—	—	
9769	653	1.1	680	1.17	706	1.25	726	1.31	743	1.3	761	1.39	789	1.45	817	1.52	846	1.61	875	1.71	935	1.95	—	—	—	—	
10194	655	1.11	681	1.19	709	1.3	731	1.34	752	1.35	774	1.45	803	1.53	831	1.62	860	1.71	889	1.82	950	2.07	—	—	—	—	

Notes:

1. Performance based on a wet coil and 2 inch (51 mm) throwaway filters.
2. Tabulated brake horsepower is the motor shaft output required.
3. Factory setting of motor sheave is 1.5 turns open. Adjustments are made in 0.5 turn increments.

Table PD-36 – Blower Speeds – TWE155B

Drive	Motor Sheave Turns Open						
	6	5	4	3	2	1	0
Standard	619	648	677	705	734	763	N/A
High Static	777	806	835	863	892	921	950



Performance Data

Air Handler

Table PD-37 – Evaporator Fan Performance TWE200B,E (I-P)

CFM	External Static Pressure (In. Of Water Column)																								
	0.10		0.20		0.30		0.40		0.50		0.60		0.70		0.80		0.90		1.00		1.20		140		
	RPM	BHP	RPM	BHP	RPM	BHP	RPM	BHP	RPM	BHP	RPM	BHP	RPM	BHP	RPM	BHP	RPM	BHP	RPM	BHP	RPM	BHP	RPM	BHP	RPM
5200	—	—	461	0.74	503	0.91	545	1.07	587	1.03	619	1.17	685	1.40	723	1.59	750	1.74	777	1.89	851	2.19	898	2.39	
5525	—	—	479	0.88	521	1.04	563	1.21	605	1.21	640	1.35	701	1.58	739	1.77	766	1.92	793	2.07	859	2.37	906	2.60	
5850	—	—	497	1.01	539	1.18	581	1.34	623	1.39	661	1.53	717	1.76	755	1.95	782	2.10	809	2.25	868	2.55	915	2.81	
6175	473	0.99	515	1.15	557	1.31	599	1.48	641	1.57	682	1.71	732	1.94	769	2.12	796	2.27	823	2.43	877	2.73	924	3.02	
6500	492	1.12	534	1.28	576	1.45	618	1.61	660	1.75	702	1.90	748	2.12	784	2.30	811	2.45	838	2.60	886	2.91	933	3.22	
6825	510	1.25	552	1.42	594	1.59	636	1.75	678	1.91	723	2.10	763	2.30	794	2.47	820	2.62	846	2.77	894	3.09	941	3.42	
7150	528	1.38	570	1.56	612	1.73	654	1.90	697	2.07	744	2.30	779	2.49	804	2.64	830	2.78	855	2.94	903	3.26	950	3.62	
7475	550	1.61	594	1.77	640	1.92	683	2.08	721	2.29	760	2.50	790	2.67	815	2.81	840	2.96	865	3.11	914	3.47	959	3.85	
7800	572	1.83	618	1.97	668	2.10	712	2.27	746	2.52	776	2.69	802	2.84	826	2.99	851	3.13	876	3.27	926	3.67	969	4.08	
3.0 HP Standard Motor and Low Static Drive			3.0 HP Standard Motor and Low Static Drive System II						3.0 HP Standard Motor and Standard Drive System						5.0 HP Oversized Motor and High Static Drive System										

Notes:

1. Performance based on a wet coil and 2 inch (51mm) throwaway filters.
2. Tabulated brake horsepower is the motor shaft output required.
3. Factory setting of motor sheave is 1.5 turns open. Adjustments are made in 0.5 turn increments.
4. Low static drive components referencing this note are field supplied.

Table PD-37 – Continued

CFM	External Static Pressure (In. Of Water Column)			
	1.60		1.80	
	RPM	BHP	RPM	BHP
5.0 HP Oversized Motor and High Static Drive System				
5200	944	2.75	989	3.12
5525	952	2.96	997	3.33
5850	961	3.17	1006	3.54
5175	970	3.38	1015	3.75
8500	978	3.59	1023	3.96
8825	986	3.80	—	—
7150	994	4.01	—	—
7475	1003	4.25	—	—
7800	1012	4.50	—	—

Table PD-37 – Evaporator Fan Performance TWE200B,E (SI)

m³/hr	External Static Pressure (Pascal)																								
	25		50		75		100		125		150		174		199		224		249		299		349		
	RPM	kW	RPM	kW	RPM	kW	RPM	kW	RPM	kW	RPM	kW	RPM	kW	RPM	kW	RPM	kW	RPM	kW	RPM	kW	RPM	kW	RPM
8835	—	—	461	0.55	503	0.68	545	0.8	587	0.77	619	0.87	685	1.04	723	1.19	750	1.3	777	1.41	851	1.63	898	1.78	
9387	—	—	479	0.66	521	0.78	563	0.9	605	0.9	640	1.01	701	1.18	739	1.32	766	1.43	793	1.54	859	1.77	906	1.94	
9939	—	—	497	0.75	539	0.88	581	1	623	1.04	661	1.14	717	1.31	755	1.45	782	1.57	809	1.68	868	1.9	915	2.1	
10491	473	0.74	515	0.86	557	0.98	599	1.1	641	1.17	682	1.28	732	1.45	769	1.58	796	1.69	823	1.81	877	2.04	924	2.52	
11044	492	0.84	534	0.95	576	1.08	618	1.2	660	1.3	702	1.42	748	1.58	784	1.72	811	1.83	838	1.94	886	2.17	933	2.4	
11596	510	0.93	552	1.06	594	1.19	636	1.3	678	1.42	723	1.57	763	1.72	794	1.84	820	1.95	846	2.07	894	2.3	941	2.55	
12148	528	1.03	570	1.16	612	1.29	654	1.42	697	1.54	744	1.72	779	1.86	804	1.97	830	2.07	855	2.19	903	2.43	950	2.7	
12700	550	1.2	594	1.32	640	1.43	683	1.55	721	1.71	760	1.87	790	1.99	815	2.1	840	2.21	865	2.32	914	2.59	959	2.87	
13252	572	1.36	618	1.47	668	1.57	712	1.69	746	1.88	776	2.01	802	2.12	826	2.23	851	2.33	876	2.44	926	2.74	969	3.04	
2.24 kW Standard Motor and Low Static Drive System			2.24 kW Standard Motor and Low Static Drive System II						2.24 kW Standard Motor and Standard Drive System						3.73 kW Oversized Motor and High Static Drive System										

Notes:

1. Performance based on a wet coil and 2 inch (51mm) throwaway filters.
2. Tabulated brake horsepower is the motor shaft output required.
3. Factory setting of motor sheave is 1.5 turns open. Adjustments are made in 0.5 turn increments.
4. Low static drive components referencing this note are field supplied.

Table PD-37 – Continued

m³/hr	External Static Pressure (Pascal)			
	398		448	
	RPM	kW	RPM	kW
3.73 kW Oversized Motor and High Static Drive System				
8835	944	2.05	989	2.33
9387	952	2.21	997	2.48
9939	961	2.36	1006	2.64
10491	970	2.52	1015	2.8
11044	978	2.68	1023	2.95
11596	986	2.83	—	—
12148	994	2.99	—	—
12700	1003	3.17	—	—
13252	1012	3.36	—	—

Table PD-38 – Blower Speeds – TWE200B,E

Drive	Motor Sheave Turns Open						
	6	5	4	3	2	1	0
Standard	706	732	758	784	811	837	863
Low Static I	457	478	500	521	542	563	585
Low Static II	574	595	617	638	659	680	702
High Static	N/A	821	862	903	945	986	1027



Performance Data

Table PD-39— Discharge Plenum And Grille Assembly Throw Distance — Air Handle — ft (m)

Unit Model No.	CFM	m ³ /h	Louver Angle Deflection Position			
			Straight	20	40	55
TWE050	1400	2380	38 (11.6)	24 (7.3)	22 (6.7)	18 (5.5)
	1600	2718	42 (12.8)	31 (9.4)	26 (7.9)	20 (6.1)
	1800	3060	46 (14.0)	37 (11.3)	29 (8.8)	22 (6.7)
	2000	3398	48 (14.6)	43 (13.1)	33 (10.1)	24 (7.3)
	2200	3737	51 (15.5)	50 (15.2)	36 (11.0)	25 (7.6)
TWE075	2100	3568	49 (14.9)	38 (11.6)	31 (9.4)	27 (8.2)
	2400	4079	52 (15.9)	43 (13.1)	35 (10.7)	29 (8.8)
	2700	4586	55 (16.8)	48 (14.6)	38 (11.6)	31 (9.4)
	3000	5098	58 (17.7)	53 (16.2)	42 (12.8)	32 (9.8)
TWE100	3200	5436	56 (17.1)	46 (14.0)	38 (11.6)	30 (9.1)
	3600	6116	62 (18.9)	51 (15.5)	42 (12.8)	33 (10.1)
	4000	6797	66 (20.1)	57 (17.4)	47 (14.3)	35 (10.7)
	4400	7477	71 (21.6)	62 (18.9)	52 (15.9)	38 (11.6)
	4800	8154	76 (23.2)	67 (20.4)	56 (17.1)	42 (12.8)
TWE155	4300	7304	42 (12.8)	32 (9.8)	29 (8.8)	21 (6.4)
	4900	8327	47 (14.3)	38 (11.6)	32 (9.8)	25 (7.6)
	5400	9176	52 (15.9)	44 (13.4)	37 (11.3)	29 (8.8)
	6000	10195	57 (17.4)	49 (14.9)	41 (12.5)	32 (9.8)
	TWE200	5600	9515	50 (15.2)	40 (12.2)	33 (10.1)
6400		10872	56 (17.1)	46 (14.0)	38 (11.6)	30 (9.1)
7200		12233	62 (18.9)	51 (15.5)	42 (12.8)	33 (10.1)
8000		13594	66 (20.1)	57 (17.4)	47 (14.3)	35 (10.7)

Throw distance values are based on a terminal velocity of 75 FPM (0.38 m/s).

Throw distance values at other terminal velocities may be established by multiplying throw distances in table above by throw factor:

Terminal Velocity	Throw Factor
50 fpm (.25 m/s) x	1.50
100 fpm (.51 m/s) x	.75
150 fpm (.76 m/s) x	.50

Table PD-40— Static Pressure Drop Through Accessories (Inches Of Water Column)¹ — Air Handler

Unit Model No.	CFM	m ³ /h	Discharge				Electric Heaters (kW)				
			Return Grille		Plenum and Grille ²		5-10	15-20	25-30	35-50	
			In. wc ¹	Pascal	In. wc ¹	Pascal	In. wc (Pascal)				
TWE050A	1400	2380	.09	(22.4)	.16	(39.8)	.06 (15.0)	.06 (15.0)	.12 (29.9)	—	
	1600	2718	.12	(29.9)	.21	(52.3)	.08 (19.9)	.08 (19.9)	.14 (34.9)	—	
	2000	3398	.18	(44.8)	.33	(82.2)	.13 (32.4)	.13 (32.4)	.19 (47.3)	—	
TWE075A	2100	3568	.05	(12.5)	.19	(47.3)	.02 (5.0)	.03 (7.5)	.05 (12.5)	.08 (19.9)	
	2400	4079	.08	(19.9)	.27	(67.2)	.03 (7.5)	.06 (15.0)	.08 (19.9)	.12 (29.9)	
	3000	5098	.13	(32.4)	.40	(99.6)	.06 (15.0)	.12 (29.9)	.17 (42.4)	.23 (57.3)	
TWE100A	2800	4756	.04	(10.0)	.34	(84.7)	.03 (7.5)	.04 (10.0)	.14 (34.9)	.20 (49.8)	
TWE100B	3200	5436	.07	(17.4)	.43	(107.1)	.06 (15.0)	.13 (32.4)	.19 (47.3)	.26 (64.8)	
TWE155B	4300	7304	.07	(17.4)	.18	(44.8)	.02 (5.0)	.02 (5.0)	.04 (10.0)	.05 (12.5)	
	4800	8154	.09	(22.4)	.23	(57.3)	.03 (7.5)	.03 (7.5)	.06 (15.0)	.08 (19.9)	
	6000	10195	.15	(37.4)	.34	(84.7)	.06 (15.0)	.06 (15.0)	.12 (29.9)	.17 (42.4)	
TWE200B,E	5600	9515	.07	(17.4)	.32	(79.7)	.04 (10.0)	.04 (10.0)	.10 (25.0)	.15 (37.4)	
	6400	10872	.11	(27.4)	.43	(107.1)	.06 (15.0)	.06 (15.0)	.13 (32.4)	.19 (47.3)	
	8000	13594	.17	(42.3)	.66	(164.3)	.10 (25.0)	.10 (25.0)	.20 (49.8)	.30 (74.7)	

1. Return air filter ESP included in Fan Performance Table data.

2. At louver opening angle of 42°F (5.5°C). For ESP at other angle openings, see accessory Installer's Guide.



Performance Data

Table PD-41 – Auxiliary Electric Heat Capacity – Air Handler

Unit Model No.	Total kW	No. of Stages	Stage 1		Stage 2		Total	
			kW Input	Btu Output	kW Input	Btu Output	kW Input	Btu Output
	5.00	1	5.00	17,065	—	—	5.00	17,065
TWE050/075/100AD	9.96	1	9.96	33,993	—	—	9.96	33,993
TWE100BD	14.96	1	14.96	51,058	—	—	14.96	51,058
	24.92	2	14.96	51,058	9.96	33,993	24.92	85,051
TWE075, 100AD								
TWE100BD	34.88	2	19.92	67,987	14.96	51,058	34.88	119,045
	10.00	1	10.00	34,130	—	—	10.00	34,130
TWE155,200B, 200E	19.92	1	19.92	67,987	—	—	19.92	67,987
	29.92	2	19.92	67,987	10.00	34,130	29.92	102,117
	49.84	2	29.92	102,117	19.92	67,987	49.84	170,104

*Heaters are rated at 400v. For other than rated voltage,
 Capacity = $\left(\frac{\text{Voltage}}{\text{Rated Voltage}}\right)^2 \times \text{Rated Capacity}$ and kW = $\left(\frac{\text{Voltage}}{\text{Rated Voltage}}\right)^2 \times \text{Rated kW}$.

Electrical Data

Table ED-1 – Unit Wiring – Condensing Units

Unit Model No.	Unit Operating Voltage	Minimum Circuit Ampacity	Maximum Fuse Size or Maximum Circuit Breaker
TTA075A	380/415	15.6	25
TTA085A	380/415	19.1	25
TTA100A	380/415	22.5	35
TTA100B	380/415	23.9	30
TTA125B	380/415	28.1	35
TTA155B	380/415	28.4	35
TTA155C	380/415	28.4	35
TTA200B	380/415	41.0	50
TTA200F	380/415	48.8	60

Table ED-2 – Electrical Characteristics – Motors – Condensing Units

Compressor Motor					Condenser Fan Motor				
Unit		Amps			Amps				
Model No.	No.	Phase	FLA (Ea.)	LRA (Ea.)	No.	Phase	FLA (Ea.)	LRA (Ea.)	
TTA075A	1	3	11.2	94.9	1	1	1.6	4.0	
TTA085A	1	3	13.1	100.0	1	1	2.7	9.3	
TTA100A	1	3	15.8	124.0	1	1	2.7	9.3	
TTA100B	2	3	9.4	63.0	1	1	2.7	9.3	
TTA125B	2	3	11.3	75.0	2	1	2.7	9.3	
TTA155B	2	3	11.2	94.9	2	1	1.6	4.0	
TTA155C	1	3	11.2	94.9	2	1	1.6	4.0	
TTA200B	2	3	15.8	124.0	2	1	2.7	9.3	
TTA200F	2	3	20.0	118.0	2	1	1.9	5.8	

NOTE:

1. Electrical characteristics reflect nameplate values and are calculated in accordance with UL and ARI specifications.

Table ED-3 – Electrical Characteristics – Motors – Air Handler

Standard Fan Motor					Oversized Fan Motor				
Unit		Amps			Amps				
Model No.	Volts	Phase	FLA	LRA	Phase	FLA	LRA		
TWE050	380/415	3	2.9	8.2	3	1.8	21.6		
TWE075	380/415	3	3.8	19.7	3	4.0	27.5		
TWE100	380/415	3	4.0	27.5	3	5.3	37.5		
TWE155	380/415	3	4.5	36.2	3	6.9	39.2		
TWE200	380/415	3	7.6	45.0	3	9.0	65.1		

Table ED-4 – Unit Wiring – Air Handler

Unit Model No.	Minimum Unit Operating Voltage Range	Maximum Fuse Circuit Ampacity	Size or Maximum Circuit Breaker
TWE050	380/415	4	15
TWE075	380/415	5	15
TWE100	380/415	5	15
TWE155	380/415	6	15
TWE200	380/415	10	15



Electric Heat Data

Table ED-5 — Unit Wiring With Electric Heat (Single Point Connection) — Air Handlers

Heater Model No.	Heater kW Rating ¹	To Use with Unit	Control Stages	Minimum Circuit Ampacity ²	Maximum Fuse Breaker Size ²
BAYHTRL405A	5.00		1	11	15
BAYHTRL410A	9.96	TWE050AD	1	17	20
BAYHTRL415A	14.96		1	24	25
BAYHTRL425A	24.92		2	37	40
BAYHTRL405A	5.00		1	12	15
BAYHTRL410A	9.96		1	18	20
BAYHTRL415A	14.96	TWE075AD	1	25	25
BAYHTRL425A	24.92		2	38	40
BAYHTRL435A	34.88		2	51	60
BAYHTRL405A	5.00		1	12	15
BAYHTRL410A	9.96		1	19	20
BAYHTRL415A	14.96	TWE100AD, TWE100BD	1	25	25
BAYHTRL425A	29.92		2	38	40
BAYHTRL435A	34.88		2	52	60
BAYHTRM410A	10.00		1	19	20
BAYHTRM420A	19.92	TWE155BD	1	32	35
BAYHTRM430A	29.92		2	46	50
BAYHTRM450A	49.84		2	72	80
BAYHTRM410A	10.00		1	23	25
BAYHTRM420A	19.92	TWE200BD	1	36	40
BAYHTRM430A	29.92	TWE200FD	2	49	50
BAYHTRM450A	49.84		2	76	80

1. kW ratings are at 400v for 3 phase, 400v air handlers

For other than rated voltage, ampacity = $\left(\frac{\text{Voltage}}{\text{Rated Voltage}}\right)^2 \times \text{Rated Capacity}$ and kW = $\left(\frac{\text{Voltage}}{\text{Rated Voltage}}\right)^2 \times \text{Rated kW}$.

2. Any power supply and circuits must be wired and protected in accordance with local codes. MCA and Maximum Fuse Size is based on 400V.

3. Field wire must be rated at least 167°F (75°C).

4. Field wire must be rated at least 194°F (90°C).

Jobsite Connections

Wiring shown with dashed lines is to be furnished and installed by the customer. All customer-supplied wiring must be copper only and must conform to local electrical codes.

NOTE:

1. When electric heater accessory is used, single point power entry or dual point power entry is field optional. Single point power entry is through electric heater only.

TTA050/TWE050A

Field Wiring:

- A — 3 power wires. Line voltage for 3 phase, 2 wires for single phase.
- B — 3 power wires. Line voltage for 3 phase, 2 wires for single phase.
- C — Cooling only thermostat: 3 wires, 24 volts.
 - One-stage electric heat: add 1 additional wire, 24 volts.
 - Two-stage electric heat: add 2 additional wires, 24 volts.
- D — 2 wires, 24 volts.

(2) TTA050/TWE100B

Field Wiring:

- A — 3 power wires. Line voltage for 3 phase, 2 wires for single phase.
- B — 3 power wires. Line voltage for 3 phase, 2 wires for single phase.
- C — Cooling only thermostat: 5 wires, 24 volts.
 - One-stage electric heat add 1 additional wire, 24 volts.
 - Two-stage electric heat: add 2 additional wires, 24 volts.
- D — 2 wires, 24 volts to outdoor section "A"
 - 2 wires, 24 volts to outdoor section "B"

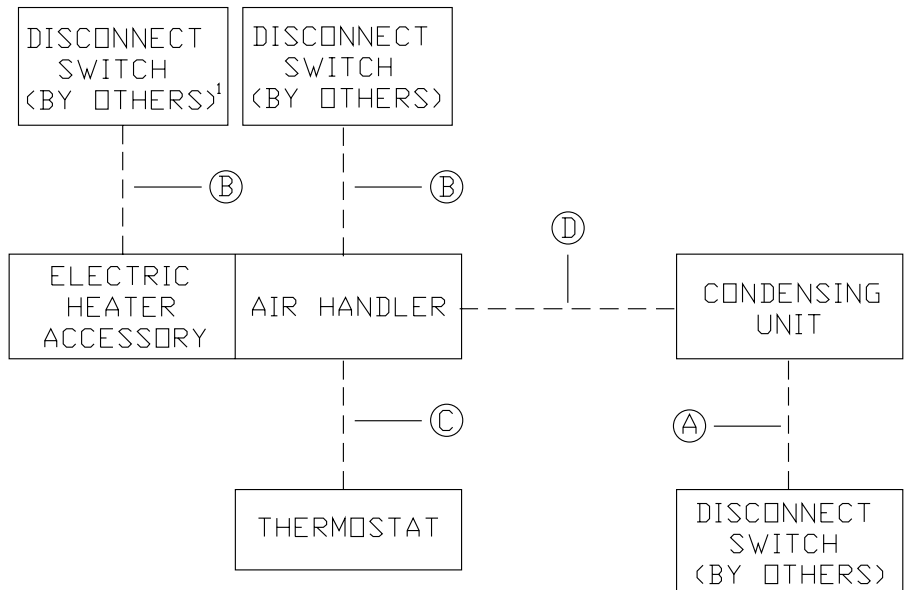

TTA075A/TWE075A;

TTA085/TWE075A;

TTA085/TWE100A;

TTA100A/TWE100A

Field Wiring:

- A — 3 power wires, line voltage.
- B — 3 power wires, line voltage for 3 phase; 2 wires for single phase.
- C — Cooling only thermostat: 4 wires, 24 volts.
 - One-stage electric heat: add 1 additional wire, 24 volts.
 - Two-stage electric heat: add 2 additional wires; 24 volts.
- D — 4 wires, 24 volts.

TTA100B/TWE100B

Field Wiring:

- A — 3 power wires, line voltage.
- B — 3 power wires, line voltage for 3 phase; 2 wires for single phase.
- C — Cooling only thermostat: 5 wires, 24 volts.
 - One-stage electric heat: add 1 additional wire, 24 volts.
 - Two-stage electric heat: add 2 additional wires, 24 volts.

- D — 5 wires, 24 volts.

TTA125B/TWE155B;

TTA155B/TWE155B;

TTA200B/TWE200B;

TTA155C/TWE155B;

TTA200F/TWE200E

Field Wiring

- A — 3 power wires, line voltage
- B — 3 power wires, line voltage
- C — Cooling only thermostat: 5 wires, 24 volts.
 - One-stage electric heat: add 1 additional wire, 24 volts.
 - Two-stage electric heat: add 2 additional wires, 24 volts.
- D — 5 wires, 24 volts.

(2) TTA075A/TWE155B;

(2) TTA100A/TWE200B

Field Wiring:

- A — 3 power wires, line voltage.
- B — 3 power wires, line voltage.
- C — Cooling only thermostat: 5 wires, 24 volts.
 - One-stage electric heat: add 1 additional wire, 24 volts.
 - Two-stage electric heat: add 2 additional wires, 24 volts.
- D — 6 wires, 24 volts.

Typical Wiring

Condensing Unit

Air Handler

Typical unit wiring diagram. For specific wiring, see wire diagram manual online.

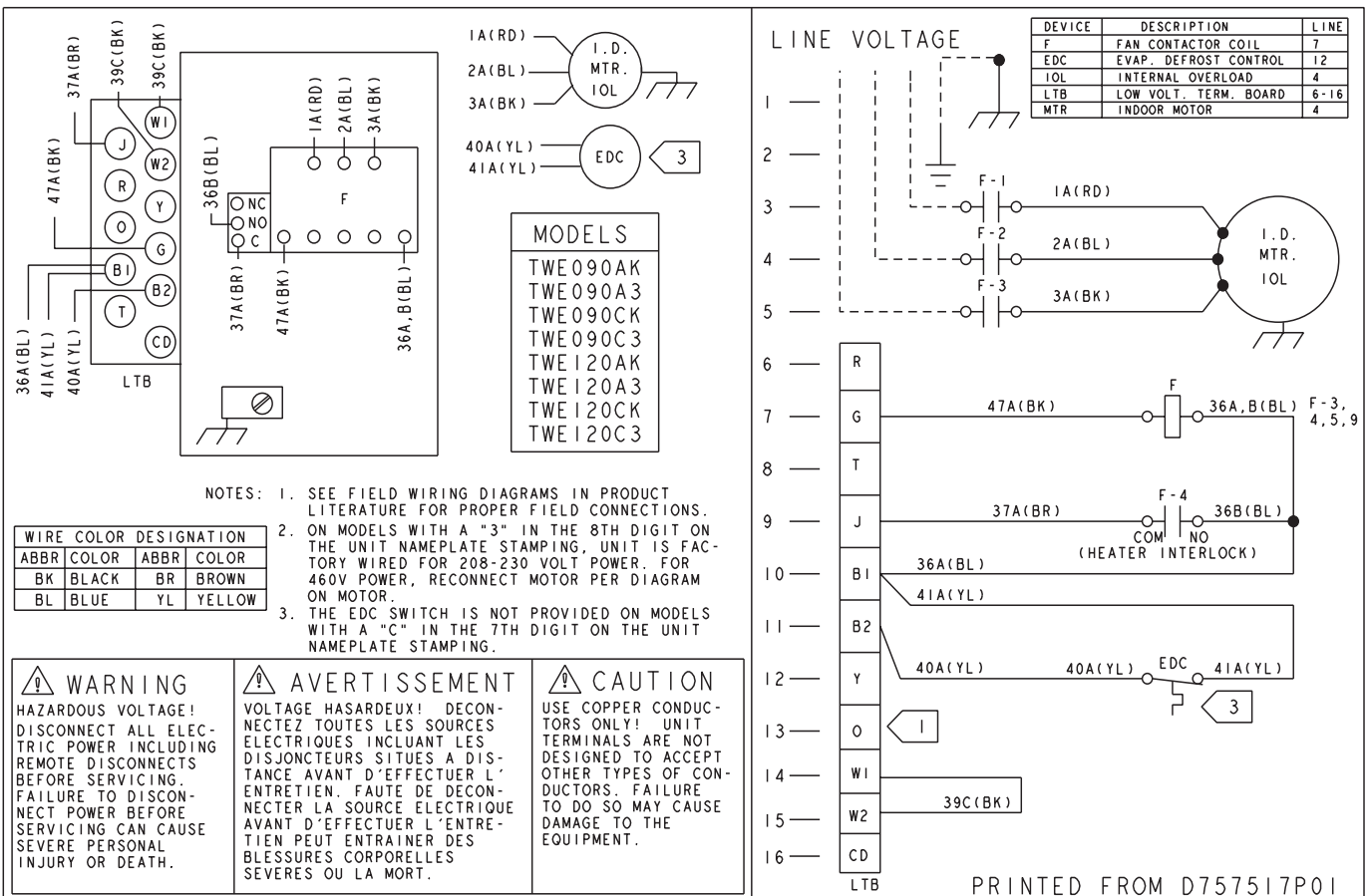

Typical Wiring

Condensing Unit

Condensing Unit — Single Compressor

Typical wiring diagram. For specific wiring, see wire diagram manual on-line.

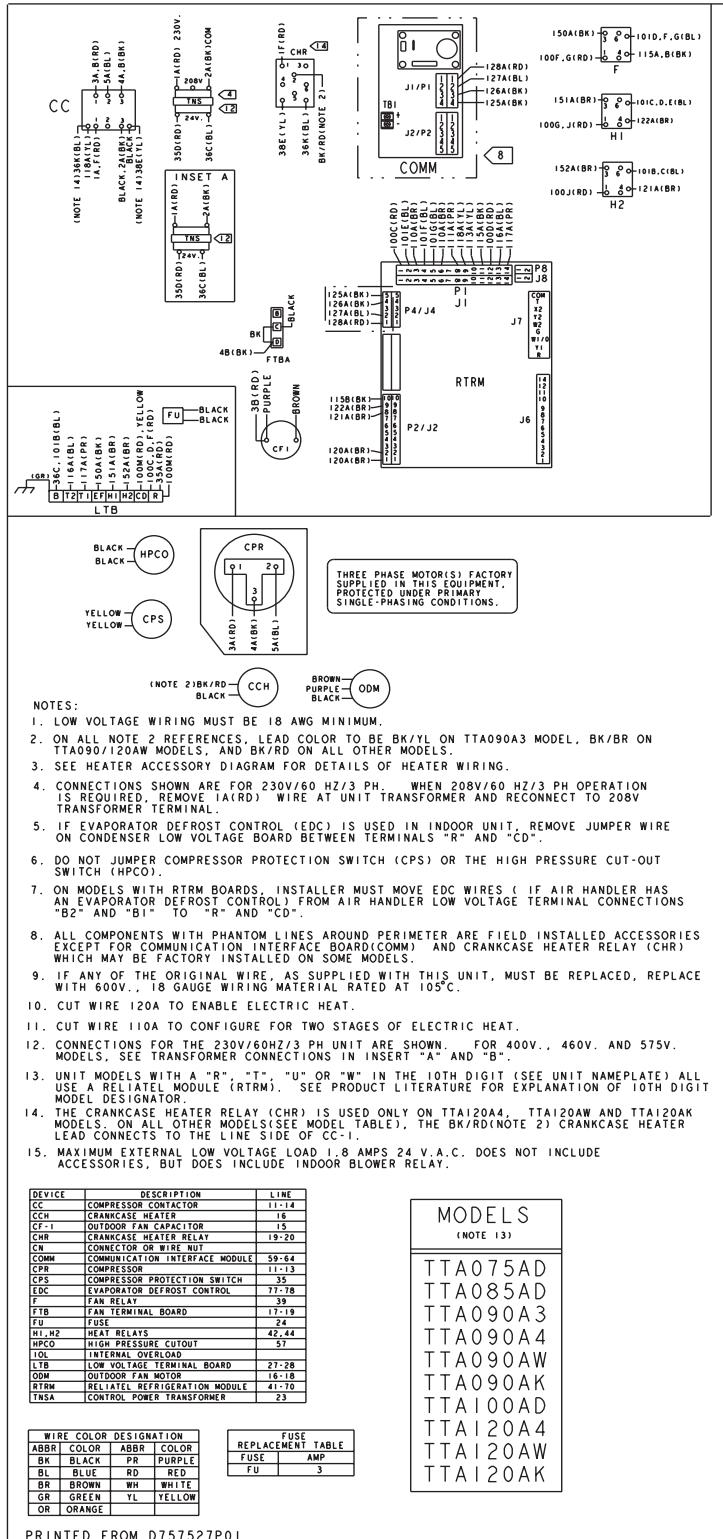

Typical Wiring

Condensing Unit

Condensing Unit — Single Compressor

Typical wiring diagram. For specific wiring, see wire diagram manual on-line.

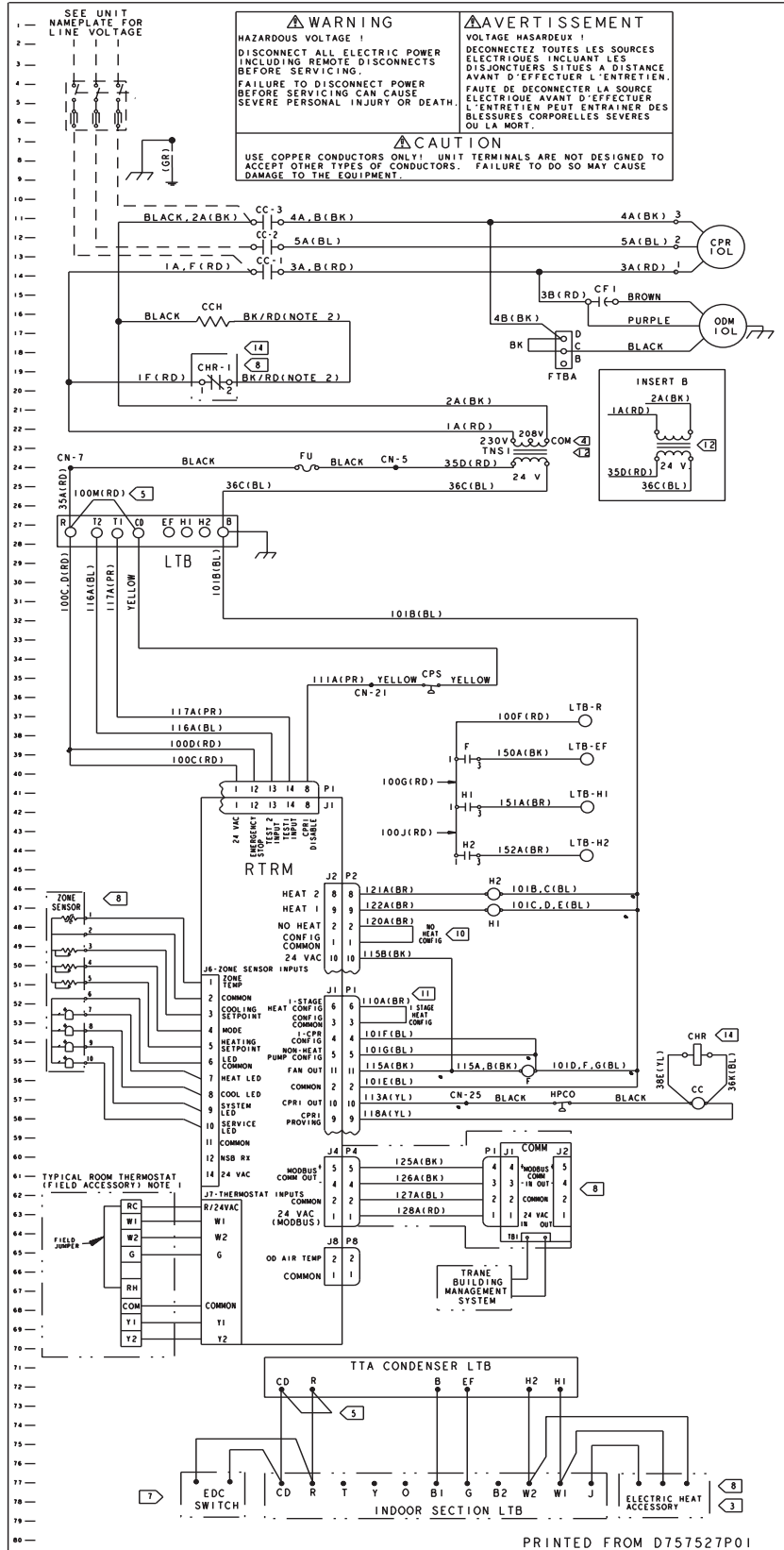

Typical Wiring Condensing Unit

Condensing Unit — Dual Compressor

Typical wiring diagram. For specific wiring, see wire diagram manual on-line.

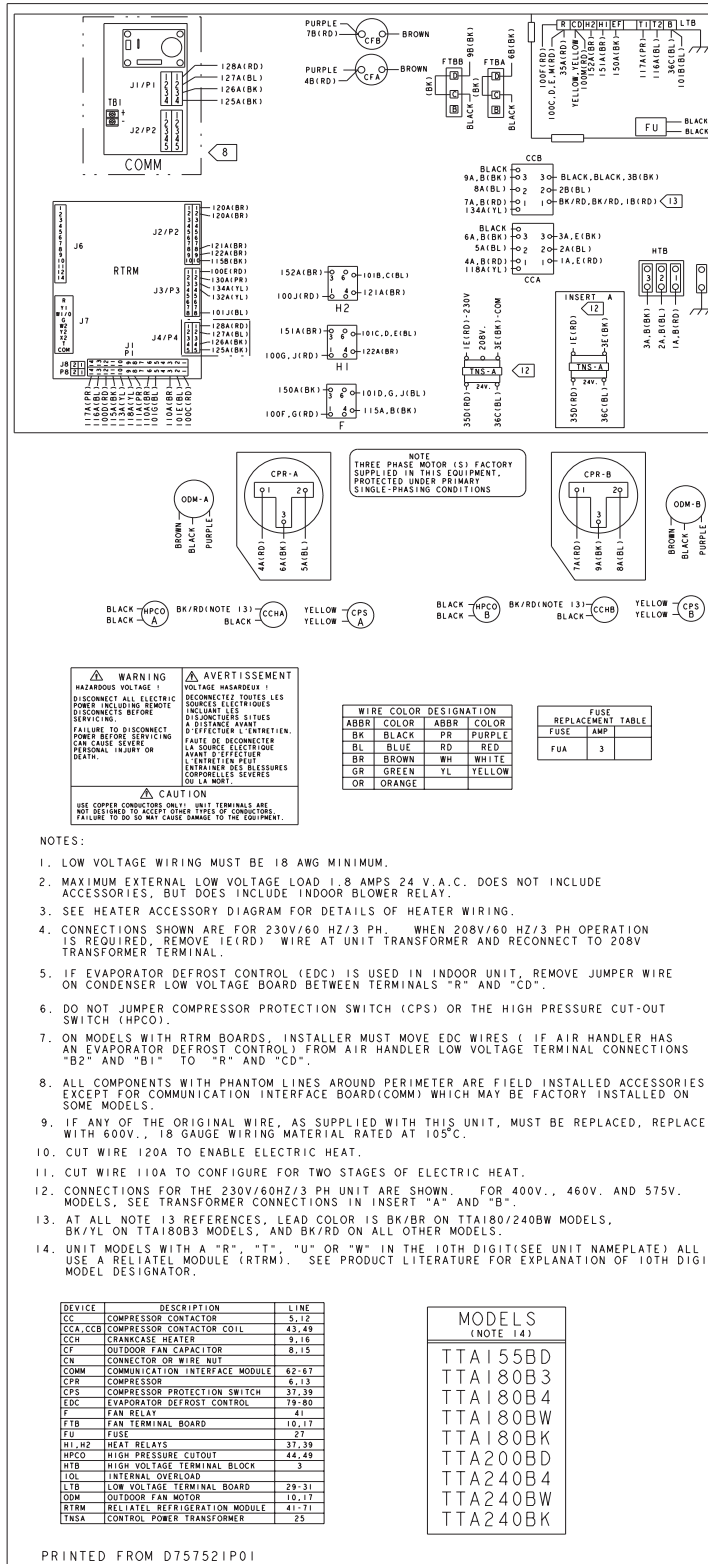

Typical Wiring

Condensing Unit — Dual Compressor

Typical wiring diagram. For specific wiring, see wire diagram manual on-line.

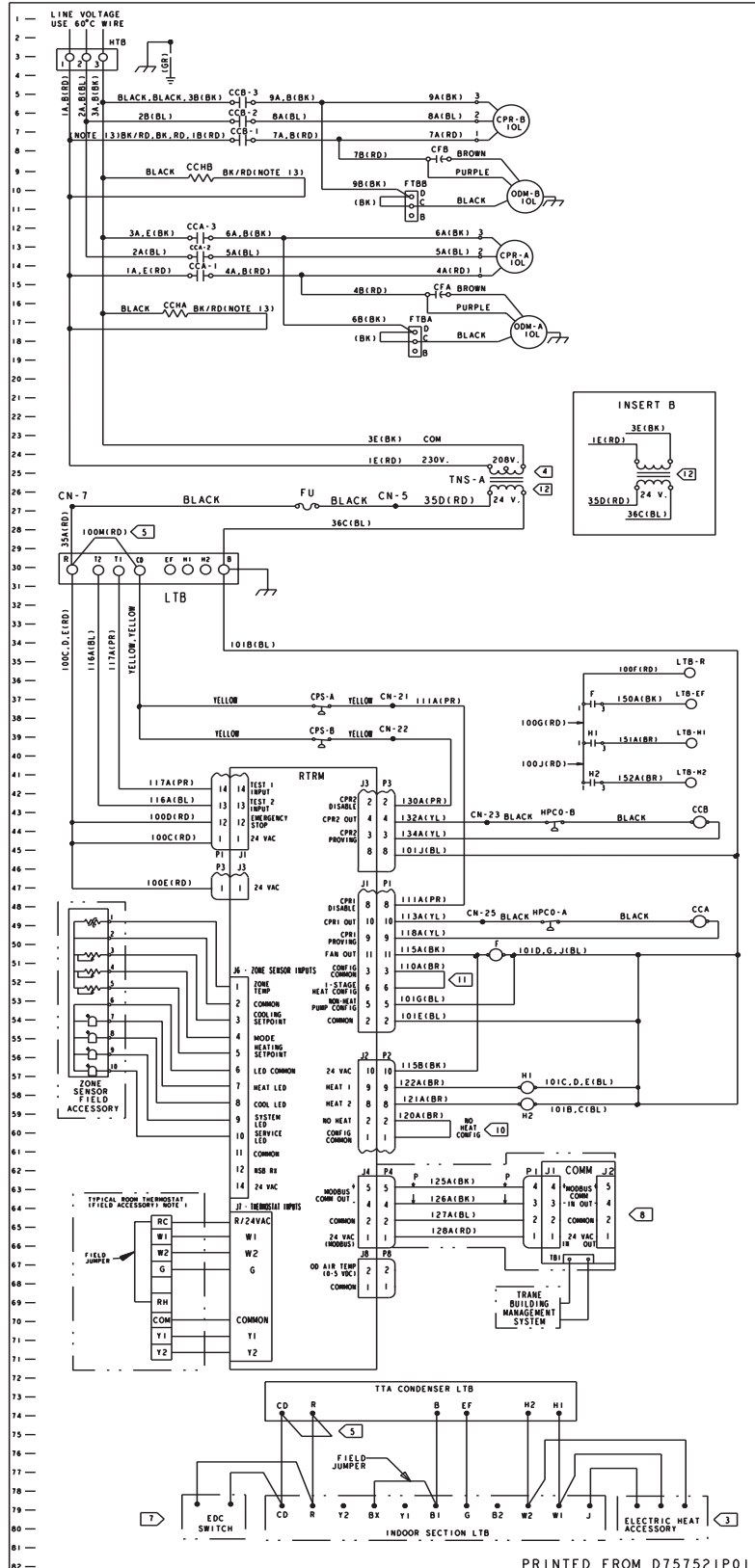

Dimensional Data

Figure DD-1 — TTA075 Condensing Units

All dimensions are in inches and millimeters.

MODEL #	APPROXIMATE CORNER WEIGHT (MASS)				TOTAL UNIT WEIGHT	TOTAL SHIPPING WEIGHT
	#1	#2	#3	#4		
TTA075A-F	105 lb	83 lb	61 lb	77 lb	326 lb	370 lb
TTA090A-F	47.6kg	37.6kg	27.7kg	34.9kg	147.8 kg	167.8 kg

- NOTES: 1. MINIMUM CLEARANCE FOR PROPER OPERATION IS 36"/914.4mm FROM WALLS, SHRUBBERY, PRIVACY FENCES, ETC. MINIMUM CLEARANCE BETWEEN ADJACENT UNITS IS 72"/1828.8mm.
2. ALL DIMENSIONS ARE GIVEN IN INCH/MILLIMETERS.
3. ALL MASSES (WEIGHT) ARE GIVEN IN POUNDS-FORCE/KILOGRAMS.

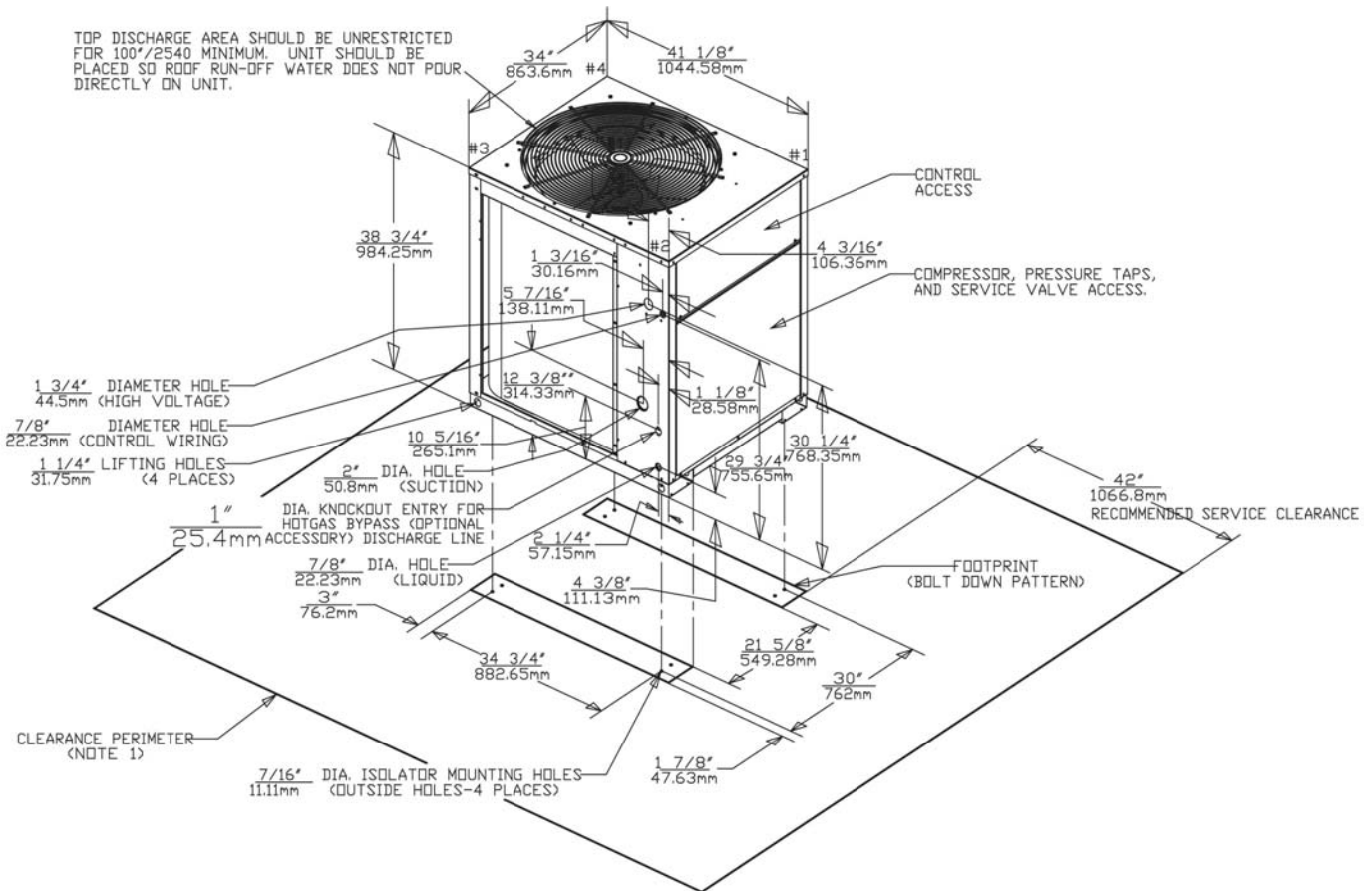

Dimensional Data

Figure DD-2 – TTA085A and 100A Condensing Units

All dimensions are in inches and millimeters.

MODEL NO.	APPROXIMATE CORNER WEIGHT [MASS]				TOTAL UNIT WEIGHT	TOTAL SHIPPING WEIGHT
	#1	#2	#3	#4		
TTA085A-F	149 lbs	116 lbs	78 lbs	100 lbs	399 lbs	443 lbs
TTA100A-F	67.6 kg	52.6 kg	35.4 kg	45.4 kg	180.9kg	200.9kg

- NOTES:
1. MINIMUM CLEARANCE FOR PROPER OPERATION IS 36"/914.4mm FROM WALLS, SHRUBBERY, PRIVACY FENCES, ETC. MINIMUM CLEARANCE BETWEEN ADJACENT UNITS IS 72"/1828.8mm
 2. ALL DIMENSIONS ARE GIVEN IN INCH/MILLIMETERS.
 3. ALL MASSES (WEIGHT) ARE GIVEN IN POUNDS-FORCE/KILOGRAMS.

TOP DISCHARGE AREA SHOULD BE UNRESTRICTED FOR 100"/2540mm MINIMUM. UNIT SHOULD BE PLACED SO ROOF RUN-OFF WATER DOES NOT POUR DIRECTLY ON UNIT.

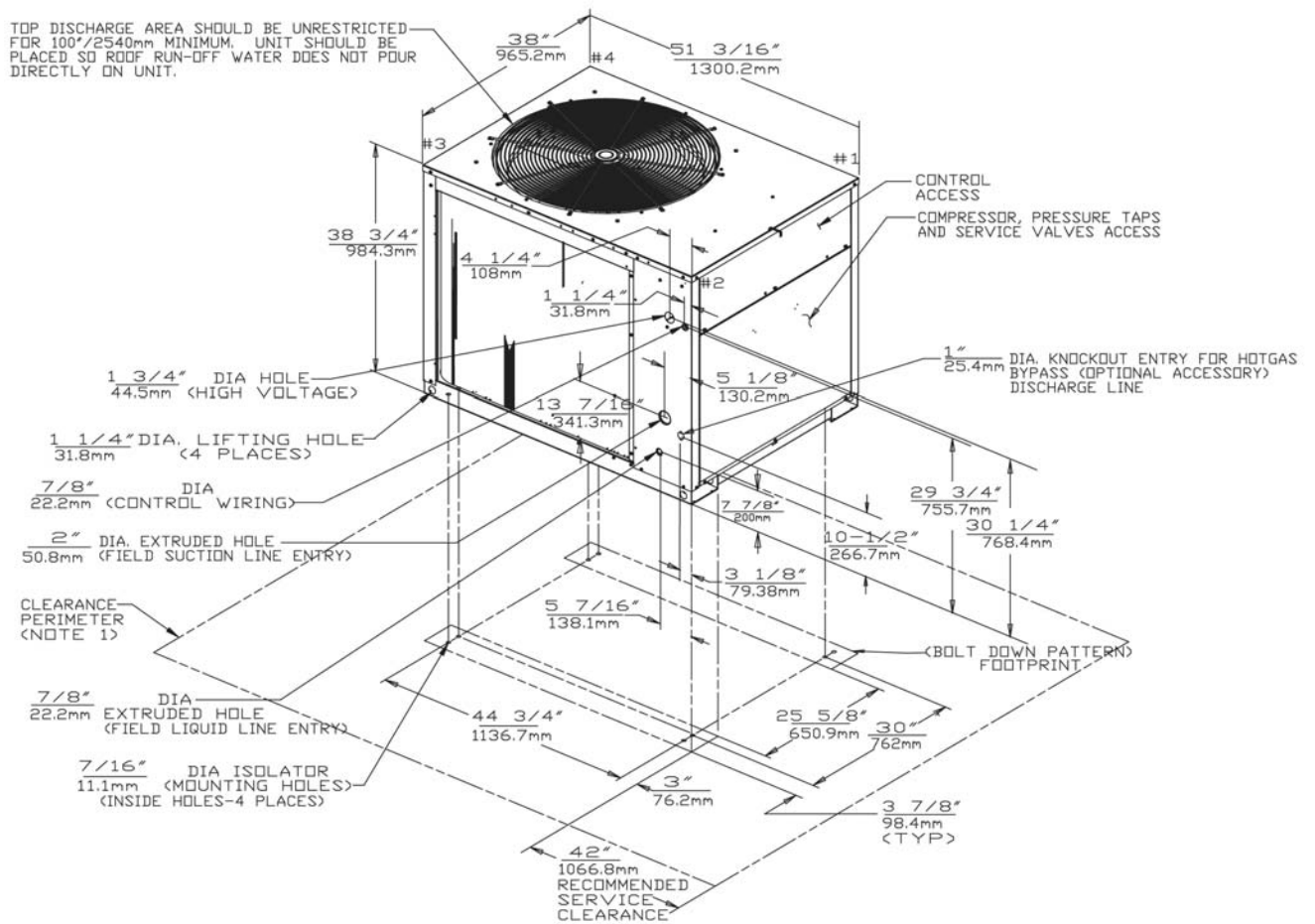

Dimensional Data

Figure DD-3 — TTA100C Condensing Units

All dimensions are in inches and millimeters.

NOTES:

1. MINIMUM CLEARANCE FOR PROPER OPERATION IS 36"/914MM FROM WALLS, SHRUBBERY, PRIVACY FENCES, ETC. MINIMUM CLEARANCE BETWEEN ADJACENT UNITS IS 72"/1830 MM.
2. ALL DIMENSIONS ARE GIVEN IN INCH/MILLIMETERS.
3. ALL MASSES (WEIGHT) ARE GIVEN IN POUNDS-FORCE/KILOGRAMS.

MODEL	APPROXIMATE CORNER WEIGHT [MASS]				TOTAL UNIT WEIGHT	TOTAL SHIPPING WEIGHT
	#1	#2	#3	#4		
TTA100C-G	133lb	122lb	87lb	95lb	437L lb	492L lb
TTA120C-G	60.3kg	55.3kg	39.5kg	43.1kg	198.2kg	223.2 kg

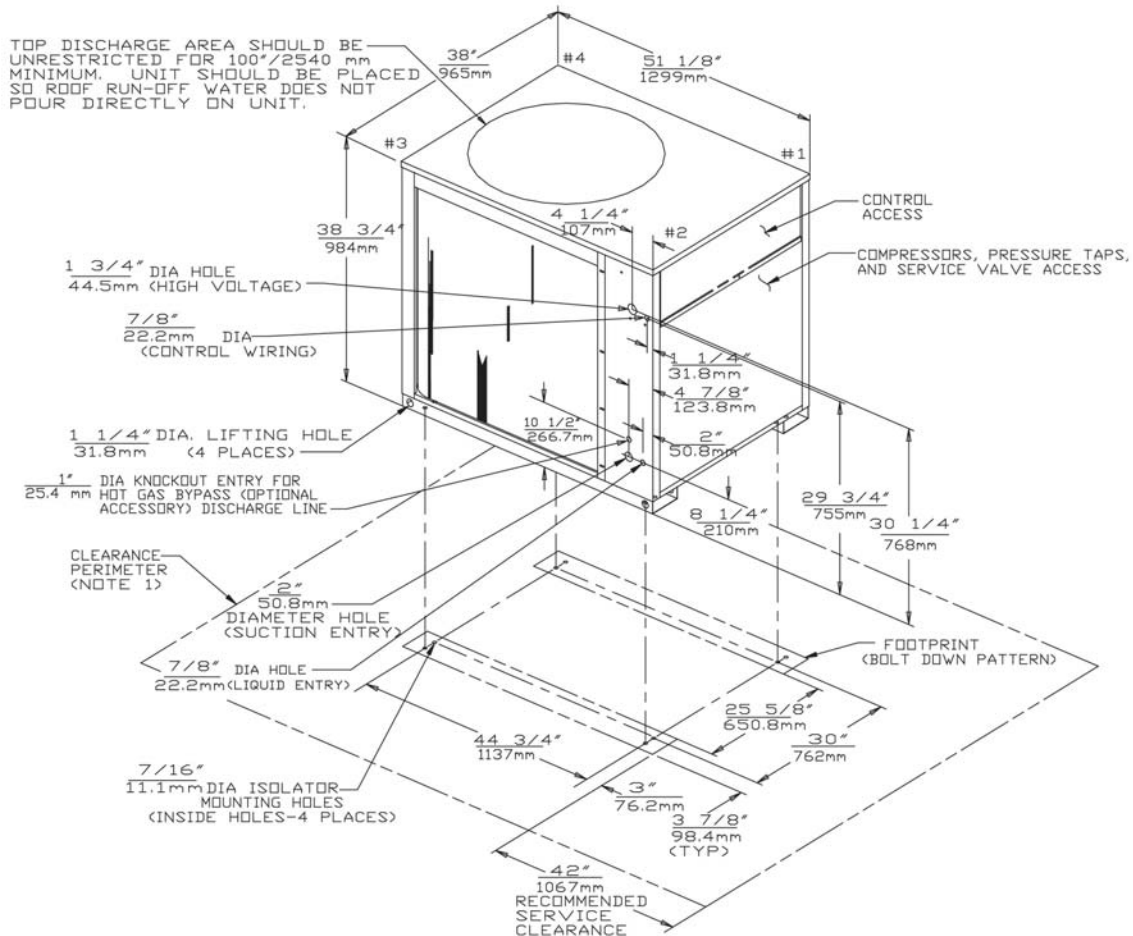

Dimensional Data

Figure DD-4 – TTA100B and TTA125B Condensing Units

All dimensions are in inches and millimeters.

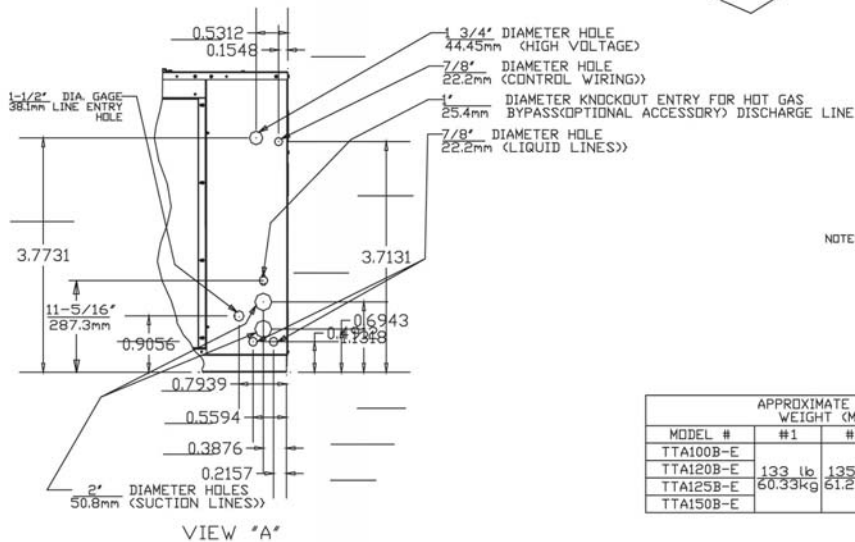
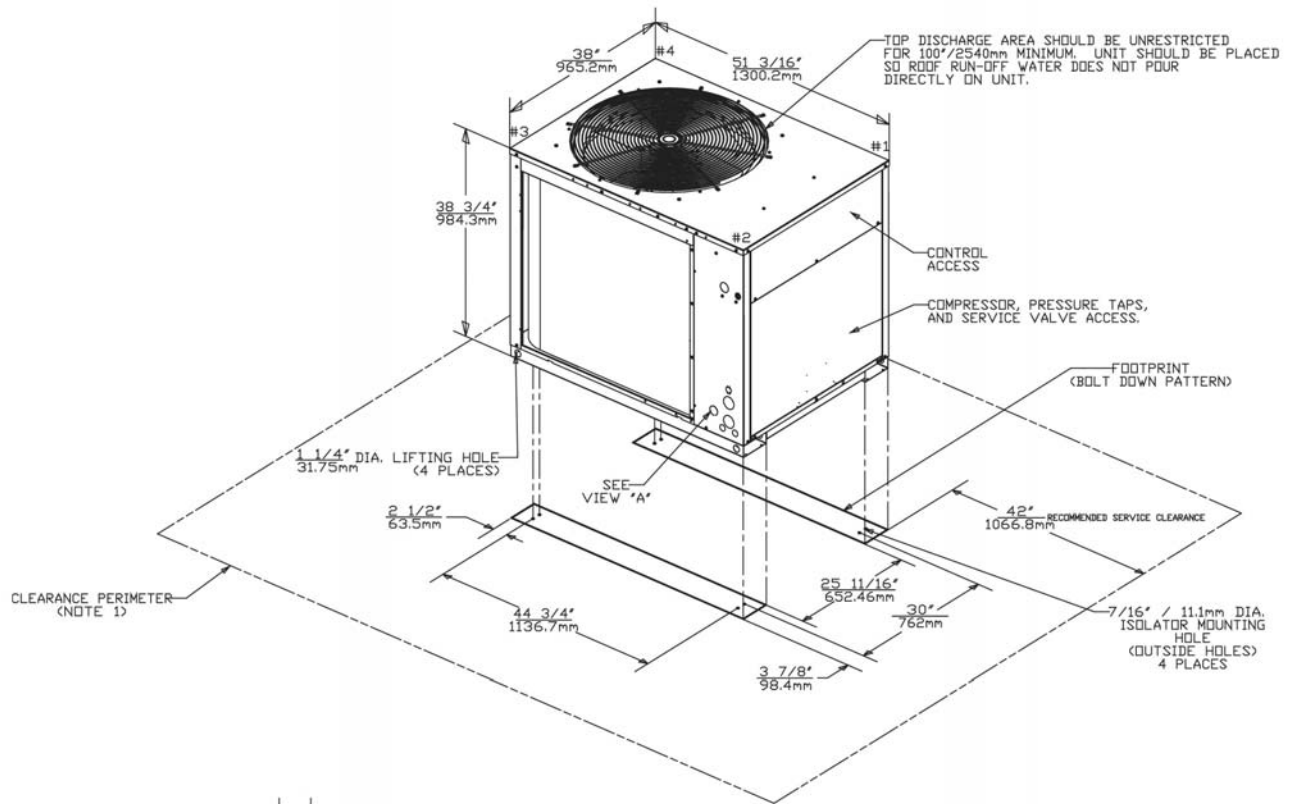

- NOTES: 1. MINIMUM CLEARANCE FOR PROPER OPERATION IS 36"/914.4mm FROM WALLS, SHRUBBERY, PRIVACY FENCES, ETC. MINIMUM CLEARANCE BETWEEN ADJACENT UNITS IS 72"/1828.8mm.
2. ALL DIMENSIONS ARE GIVEN IN INCH/MILLIMETERS.
3. ALL MASSES (WEIGHT) ARE GIVEN IN POUNDS-FORCE/KILOGRAMS.

MODEL #	APPROXIMATE CORNER WEIGHT (MASS)				TOTAL UNIT WEIGHT	TOTAL SHIPPING WEIGHT
	#1	#2	#3	#4		
TTA100B-E						
TTA120B-E	133 lb	135 lb	87 lb	85 lb	427 lb	481 lb
TTA125B-E	60.33kg	61.24kg	39.46kg	38.56kg	193.68kg	218.17kg
TTA150B-E						

Dimensional Data

Figure DD- 5— TTA155B Condensing Unit

All dimensions are in inches and millimeters.

MODEL NO.	APPROXIMATE CORNER WEIGHT (MASS)				TOTAL UNIT WEIGHT	TOTAL SHIPPING WEIGHT
	#1	#2	#3	#4		
TTA155BD-F	196 lbs	193 lbs	144 lbs	146 lbs	679 lbs	764 lbs
TTA180B-F	88.9 kg	87.5 kg	65.3 kg	66.2 kg	308 kg	354.2 kg

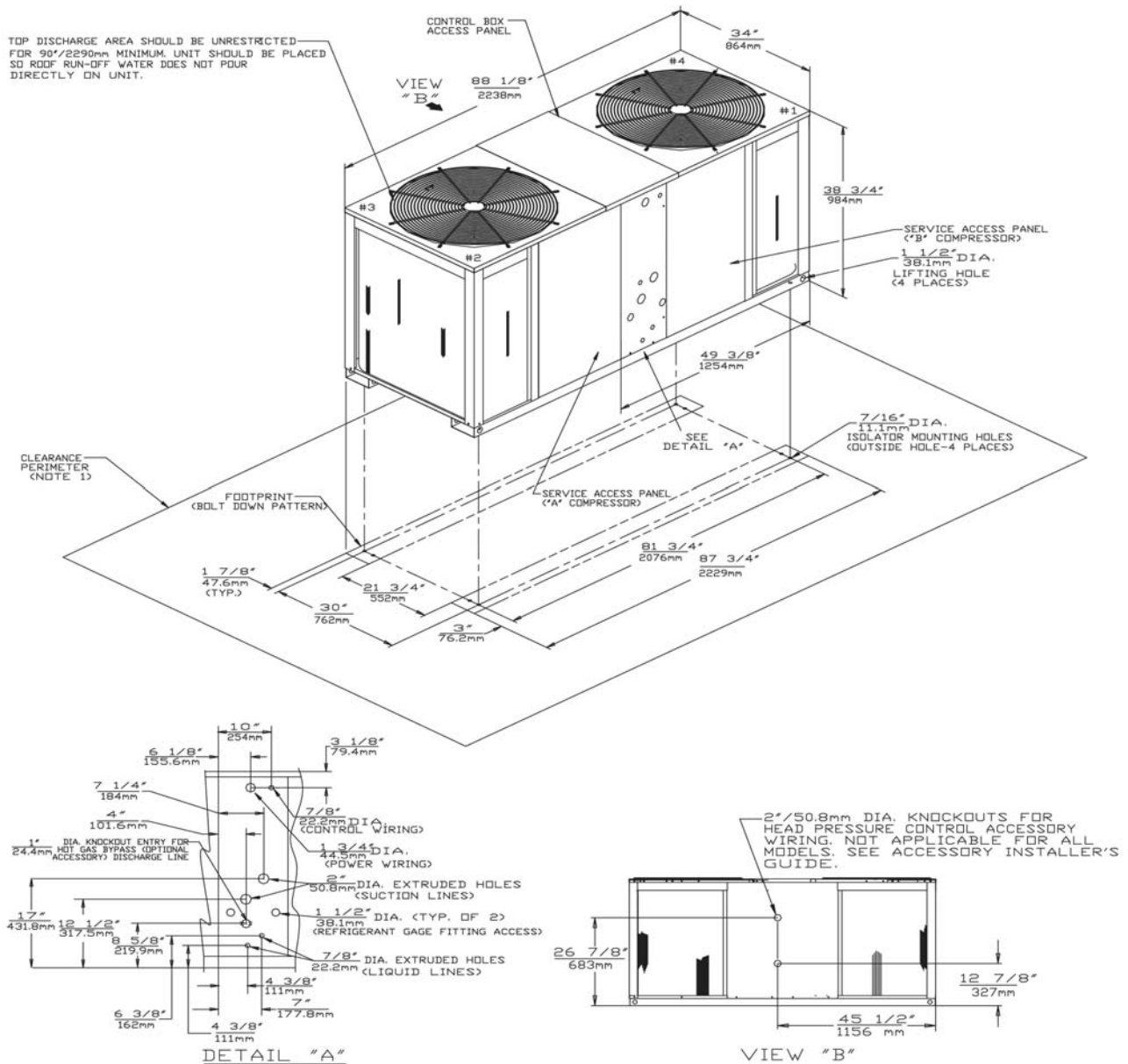

Dimensional Data

Figure DD-6 – TTA155C Condensing Units
 All dimensions are in inches and millimeters.

MODEL	APPROXIMATE CORNER WEIGHT [MASS]				TOTAL UNIT WEIGHT	TOTAL SHIPPING WEIGHT
	#1	#2	#3	#4		
TTA155C-G	196 lb	193 lb	144 lb	146 lb	679 lb	764 lb
TTA180C-G	88.9 kg	87.5 kg	65.3 kg	66.2 kg	308 kg	354.2kg

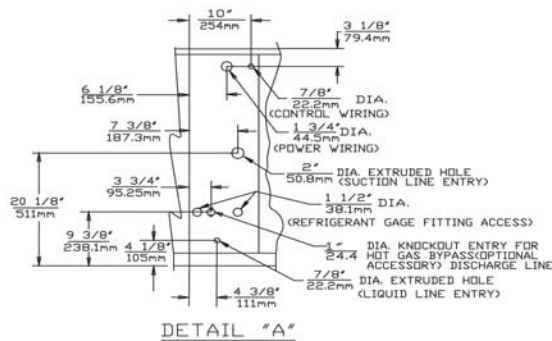
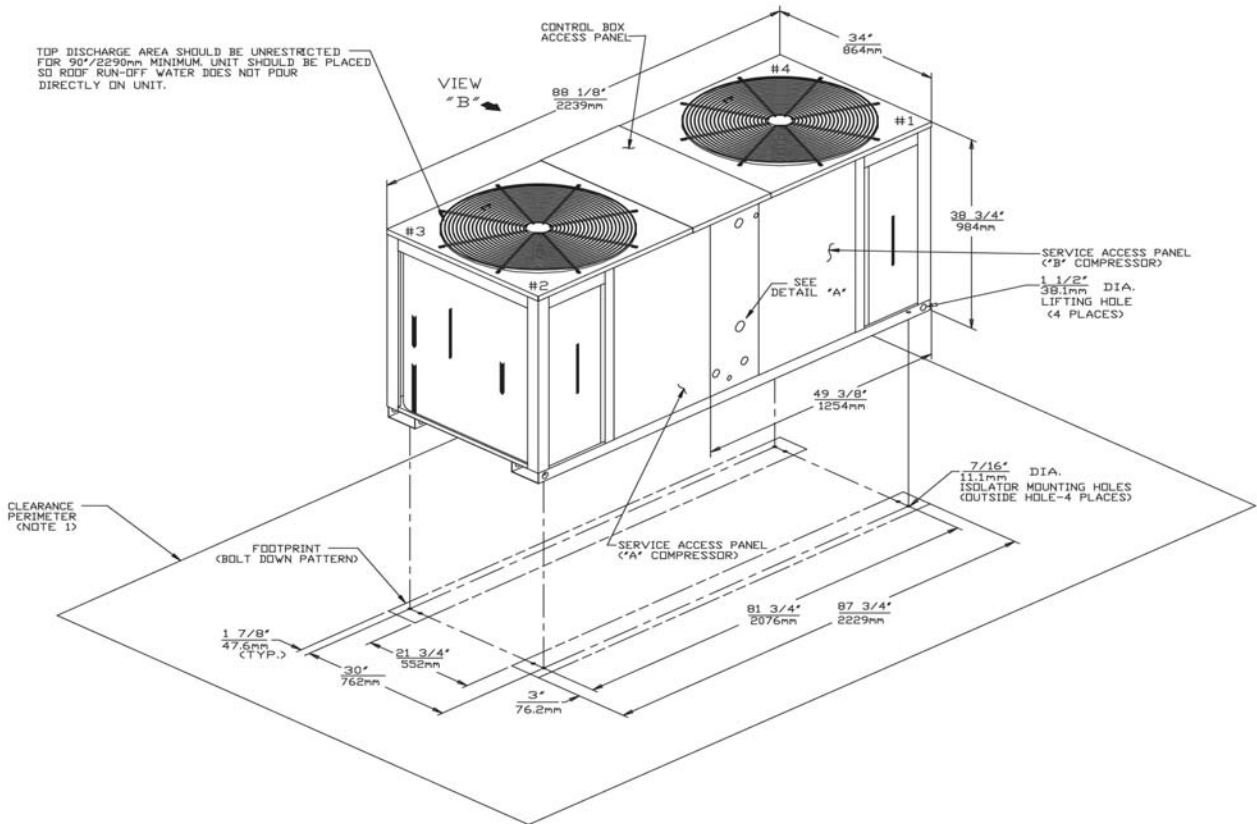

2"/50.8mm DIA. KNOCKOUTS FOR HEAD PRESSURE CONTROL ACCESSORY WIRING. NOT APPLICABLE FOR ALL MODELS. SEE ACCESSORY INSTALLER'S GUIDE.

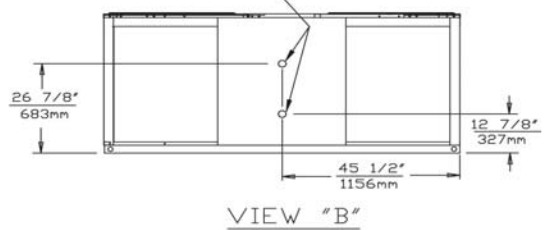

Dimensional Data

Figure DD-7 — TTA200B Condensing Unit

All dimensions are in inches and millimeters.

MODEL NO.	APPROXIMATE CORNER WEIGHT (MASS)				TOTAL UNIT WEIGHT	TOTAL SHIPPING WEIGHT
	#1	#2	#3	#4		
TTA240B---F	247lbs	247lbs	168lbs	168lbs	830 lb	915 lb
TTA200BD--F	112kg	112kg	76.2kg	76.2kg	376.5 kg	415 kg

NOTES:

1. MINIMUM CLEARANCE FOR PROPER OPERATION IS 36"/914mm FROM WALLS SHRUBBERY, PRIVACY FENCES ETC. MINIMUM CLEARANCE BETWEEN ADJACENT UNITS IS 72"/1830mm .
2. ALL DIMENSIONS ARE GIVEN IN INCH/MILLIMETERS.
3. ALL MASSES (WEIGHT) ARE GIVEN IN POUNDS-FORCE/KILOGRAMS.

TOP DISCHARGE AREA SHOULD BE UNRESTRICTED FOR 100"/2540 mm MINIMUM. UNIT SHOULD BE PLACED SO ROOF RUN-OFF WATER DOES NOT POUR DIRECTLY ON UNIT.

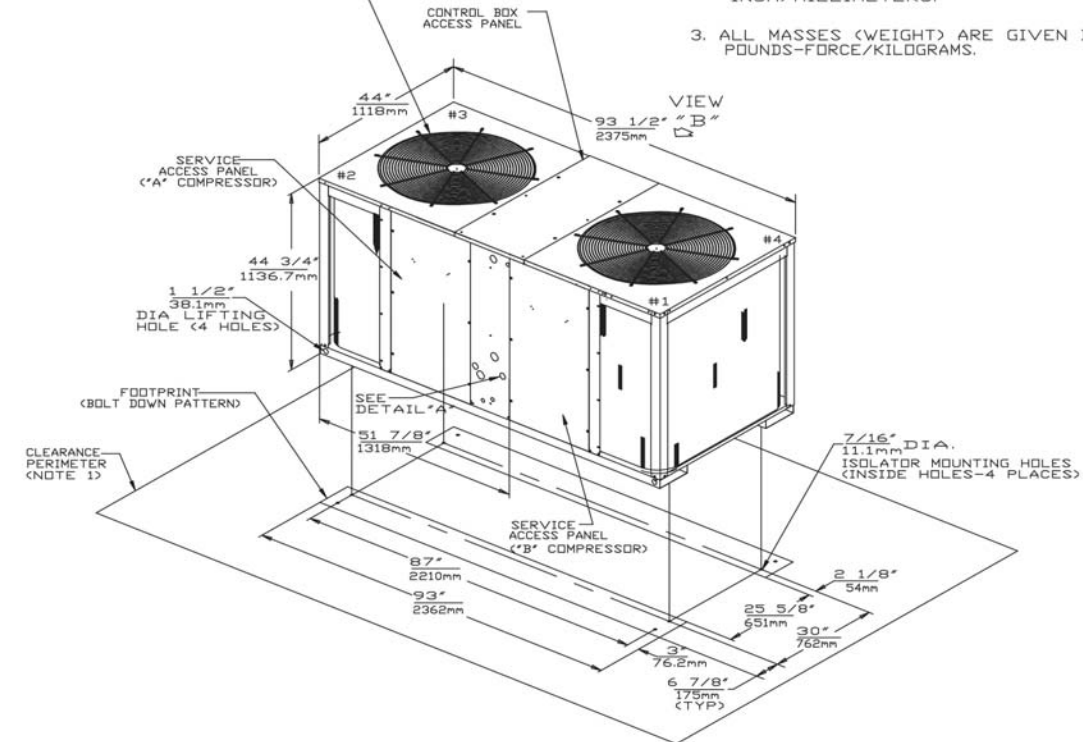

2"/50.8mm DIA. KNOCKOUTS. (FOR 575V HEAD PRESSURE CONTROL WIRING)

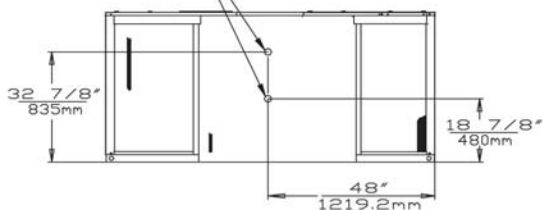

VIEW "B"

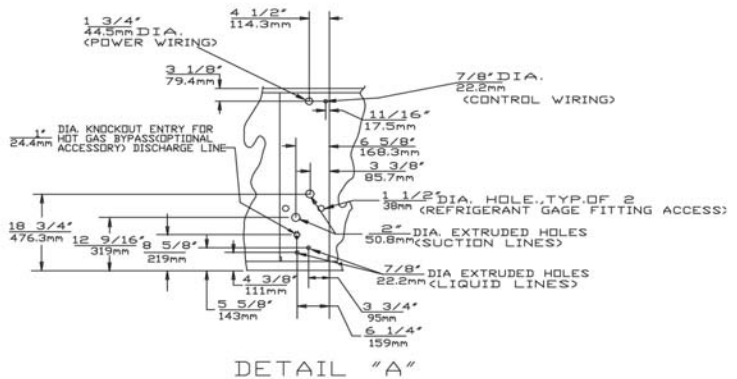

DETAIL "A"

Dimensional Data

Figure DD-8 – TTA200F Condensing Unit

All dimensions are in inches and millimeters.

TOP DISCHARGE AREA SHOULD BE UNRESTRICTED FOR 100" / 2540 mm MINIMUM. UNIT SHOULD BE PLACED SO ROOF RUN-OFF WATER DOES NOT POUR DIRECTLY ON UNIT.

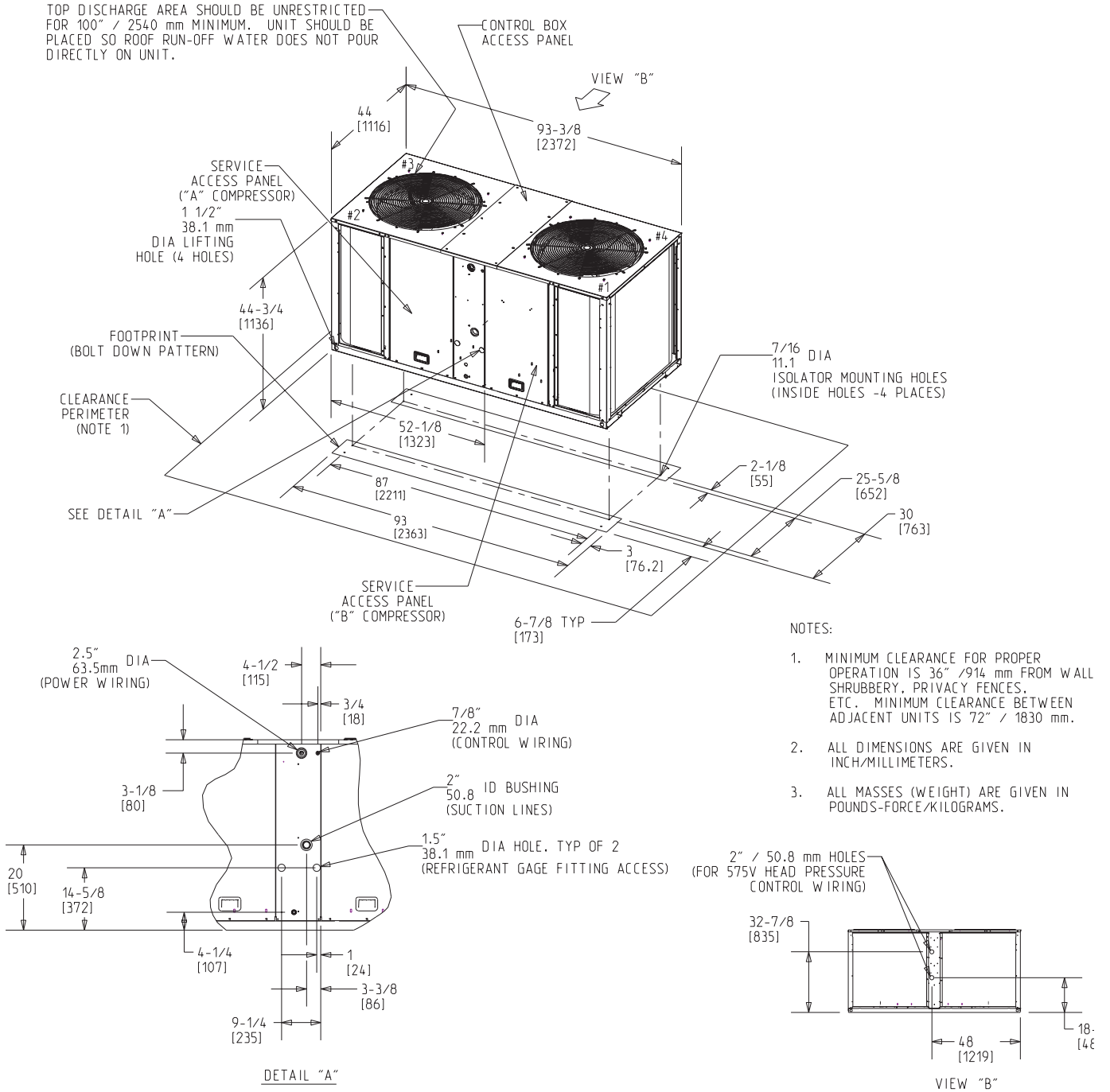

Dimensional Data

Figure DD-9 – TWE050A Air Handlers

All dimensions are in inches and millimeters.

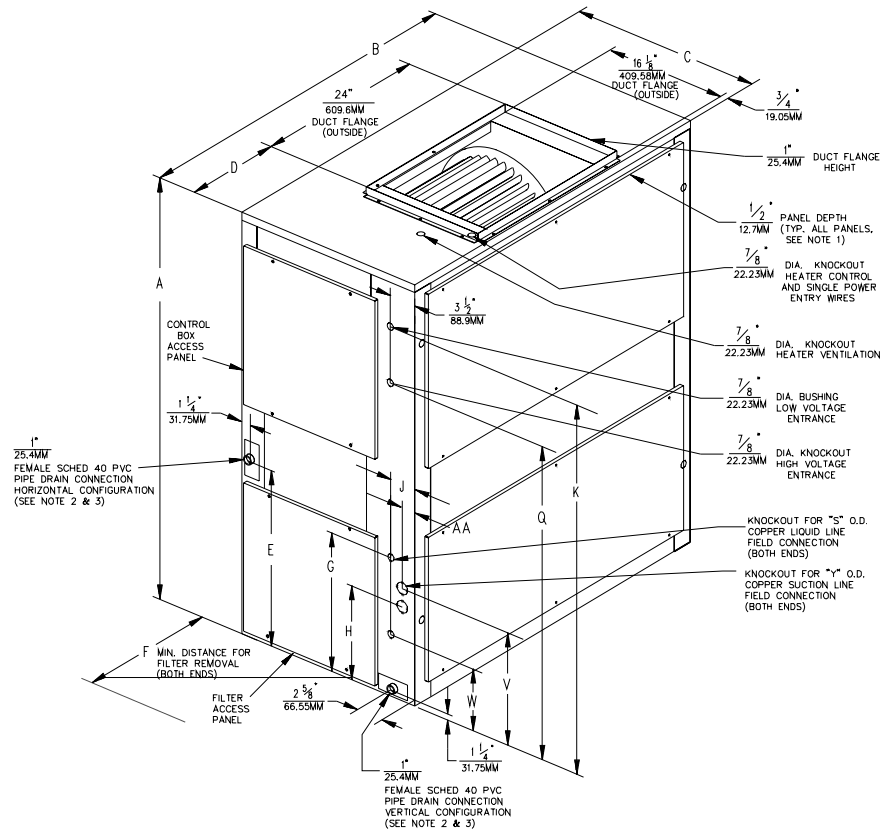

NOTES:

1. LENGTH, WIDTH, AND HEIGHT DIMENSIONS DO NOT INCLUDE 1/2" ACCESS PANEL DEPTH.
2. REMOVABLE DRAIN PAN AND ATTACHED DRAIN CONNECTION MAY BE INSTALLED ON EITHER END OF UNIT IN EITHER THE VERTICAL OR HORIZONTAL CONFIGURATION. PLASTIC DRAIN PAN ACCESS PLATE ON THE END OF UNIT OPPOSITE DRAIN CONNECTION MUST BE REMOVED TO SLIDE DRAIN PAN OUT OF UNIT FOR CLEANING. ACCESS PLATE MUST BE RE-INSTALLED AFTER SLIDING DRAIN PAN BACK INTO UNIT.
3. IF PERIODIC DRAIN PAN CLEANING IS REQUIRED, ALLOW ROOM FOR PARTIAL REMOVAL OF PAN ON DRAIN CONNECTION END OF UNIT.

Table DD-1 – Air Handler Dimensions – in. (mm)

Model No.	A	B	C	D	E	F	G	H
TWE050A	48 (1219.20)	38 (965.20)	22 (558.80)	8 (203.20)	19-1/2 (495.30)	26 (660.40)	15-7/8 (403.23)	14-1/8 (358.78)

Table DD-1 – (Continued)

Model No.	J	K	Q	S	V	W	Y	AA
TWE050A	1-7/8 (47.63)	42-1/8 (1069.98)	34-5/8 (879.48)	3/8 (9.53)	—	—	1-1/8 (28.58)	1-7/8 (47.63)

Dimensional Data

Figure DD-10— TWE075A; TWE100A, 100B Air Handlers

All dimensions are in inches and millimeters.

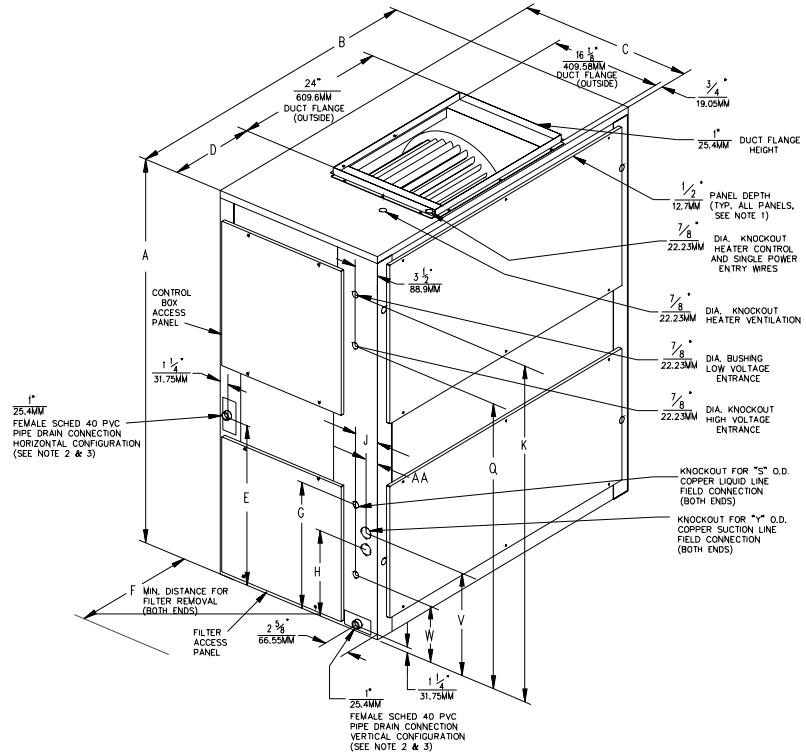

- NOTES:
1. LENGTH, WIDTH, AND HEIGHT DIMENSIONS DO NOT INCLUDE 1/2" ACCESS PANEL DEPTH.
 2. REMOVABLE DRAIN PAN AND ATTACHED DRAIN CONNECTION MAY BE INSTALLED ON EITHER END OF UNIT IN EITHER THE VERTICAL OR HORIZONTAL CONFIGURATION. PLASTIC DRAIN PAN ACCESS PLATE ON THE END OF UNIT OPPOSITE DRAIN CONNECTION MUST BE REMOVED TO SLIDE DRAIN PAN OUT OF UNIT FOR CLEANING. ACCESS PLATE MUST BE RE-INSTALLED AFTER SLIDING DRAIN PAN BACK INTO UNIT.
 3. IF PERIODIC DRAIN PAN CLEANING IS REQUIRED, ALLOW ROOM FOR PARTIAL REMOVAL OF PAN ON DRAIN CONNECTION END OF UNIT.

Table DD-2 – Air Handler Dimensions – in. (mm)

Tons	Model No.	A	B	C	D	E	F	G	H
	TWE075A	54 (1371.60)	47-1/2 (1206.50)	25 (635.00)	11-3/4 (298.45)	22-3/8 (568.33)	22 (558.80)	—	17-3/4 (450.85)
	TWE100A	54 (1371.60)	63-12 (1612.90)	25 (635.00)	19-3/4 (501.65)	22-3/8 (568.33)	22 (558.80)	—	17-3/4 (450.85)
	TWE100B	54 (1371.60)	63-1/2 (1612.90)	25 (635.00)	19-3/4 (501.65)	22-3/8 (568.33)	22 (558.80)	20-1/8 (511.18)	16 (406.40)

Table DD-2 – (Continued)

Model No.	J	K	Q	S	V	W	Y	AA
TWE075A	4 (101.60)	45-1/4 (1149.35)	38-1/8 (968.38)	1/2 (12.70)	—	15 (381.00)	1-3/8 (34.93)	2 (50.80)
TWE100A	4 (101.60)	45-1/4 (1149.35)	38-1/8 (968.38)	1/2 (12.70)	—	15 (381.00)	1-3/8 (34.93)	2 (50.80)
TWE100B	2-1/8 (53.98)	45-1/4 (1149.35)	38-1/8 (968.38)	3/8 (9.53)	18-3/4 (476.25)	14 (355.60)	1-1/8 (28.58)	2-1/8 (53.98)

Dimensional Data

Figure DD-11 – TWE050A, 075A 100A; TWE100B Air Handlers

All dimensions are in inches and millimeters.

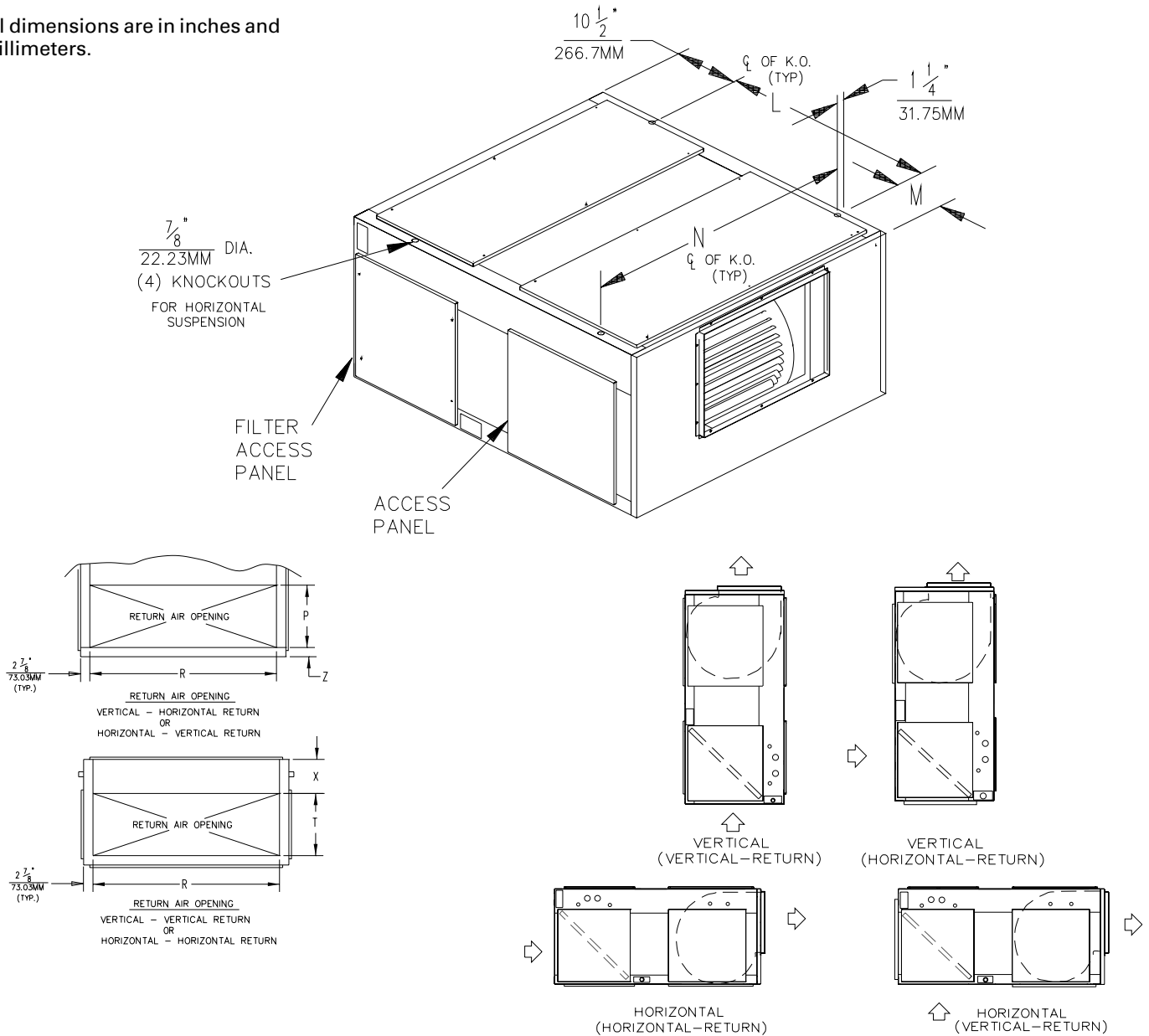

Table DD-3 – Air Handler Dimensions – in. (mm)

Model No.	L	M	N	P	R	T	X	Z
TWE050A	34-5/8 (879.48)	2-7/8 (73.03)	35-5/8 (904.88)	12-1/4 (311.15)	32-1/4 (819.15)	12-1/2 (317.50)	7-5/8 (193.68)	2 (50.80)
TWE075A	36-7/8 (936.63)	6-5/8 (168.28)	45-1/8 (1146.18)	16-1/8 (409.58)	41-3/4 (1060.45)	16-1/4 (412.75)	6-7/8 (174.63)	1-3/4 (44.45)
TWE100A, 100B	36-7/8 (936.63)	6-5/8 (168.28)	61-1/8 (1552.58)	16-1/8 (409.58)	57-3/4 (1466.85)	16-1/4 (412.75)	6-7/8 (174.63)	1-3/4 (44.45)

Dimensional Data

Figure DD-12— TWE155B and 200B Air Handlers

All dimensions are in inches and millimeters.

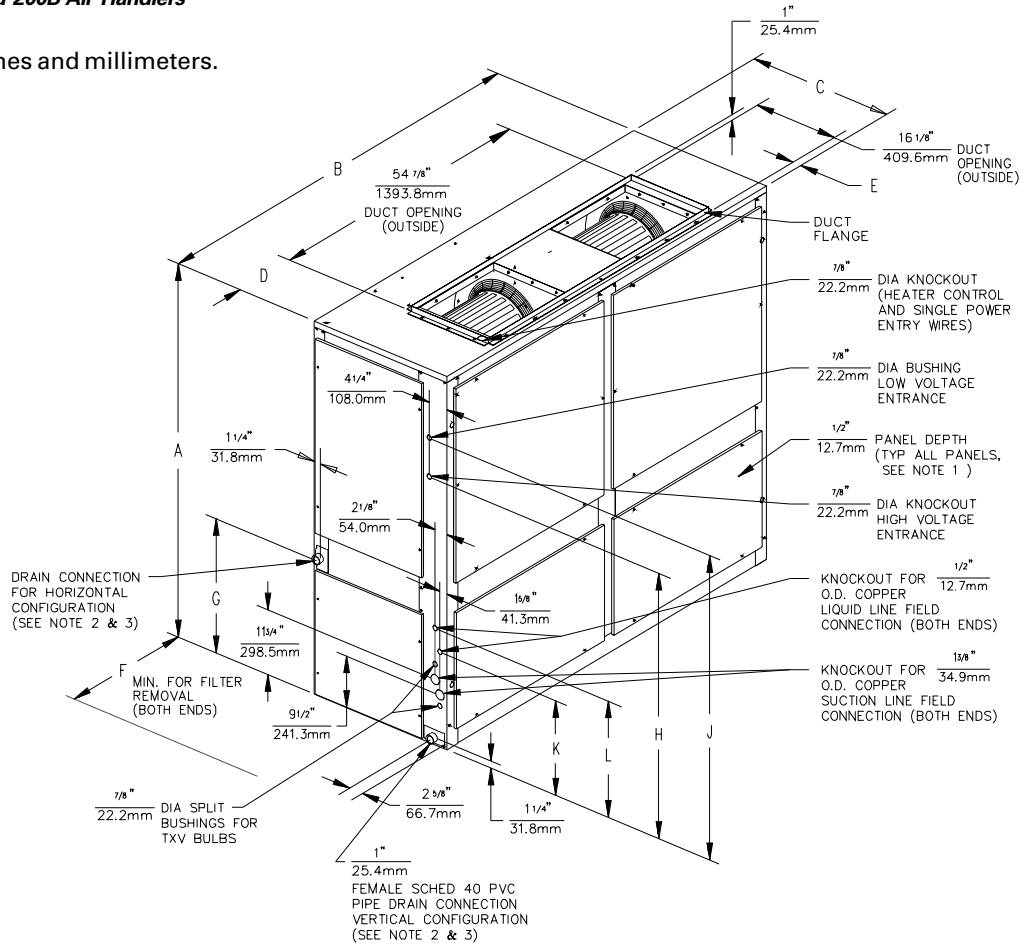

NOTES:

1. LENGTH, WIDTH, AND HEIGHT DIMENSIONS DO NOT INCLUDE 1/2" ACCESS PANEL DEPTH.
2. REMOVABLE DRAIN PAN AND ATTACHED DRAIN CONNECTION MAY BE INSTALLED ON EITHER END OF UNIT IN EITHER THE VERTICAL OR HORIZONTAL CONFIGURATION. PLASTIC DRAIN PAN ACCESS PLATE ON THE END OF UNIT OPPOSITE DRAIN CONNECTION MUST BE REMOVED TO SLIDE DRAIN PAN OUT OF UNIT FOR CLEANING. ACCESS PLATE MUST BE RE-INSTALLED AFTER SLIDING DRAIN PAN BACK INTO UNIT.
3. IF PERIODIC DRAIN PAN CLEANING IS REQUIRED, ALLOW ROOM FOR PARTIAL REMOVAL OF PAN ON DRAIN CONNECTION END OF UNIT.

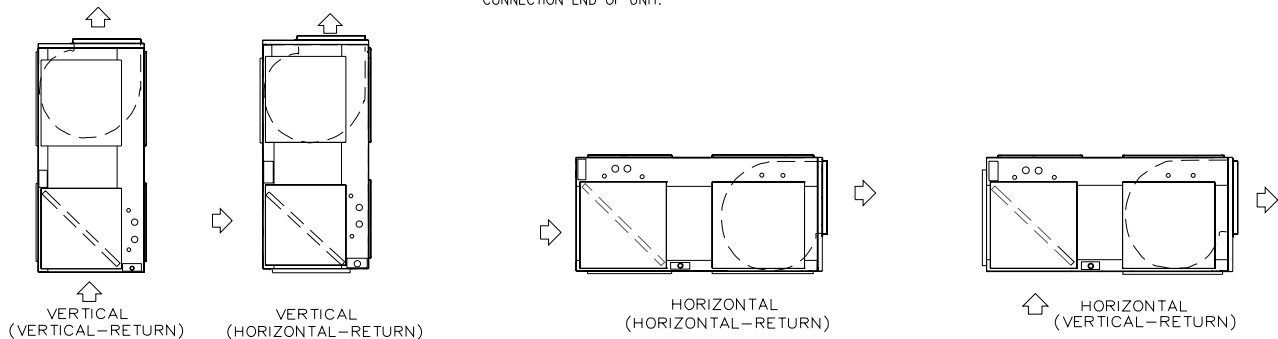

Dimensional Data

Figure DD-13 – TWE155B and 200B Air Handlers
All dimensions are in inches and millimeters.

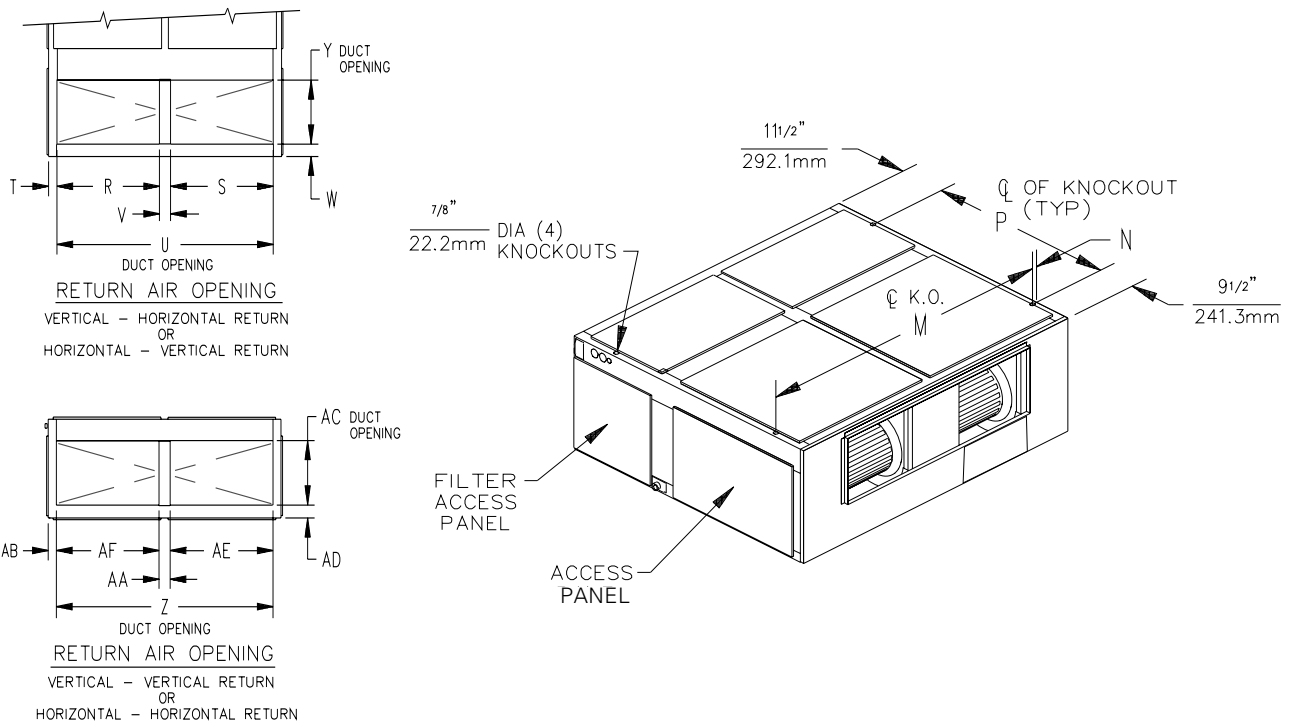

Table DD-4 – Air Handler Dimensions – in. (mm)

Model No.	A	B	C	D	E	F	G	H	J	K
TWE155B	69 (1752.60)	79-1/2 (2019.30)	27-5/8 (701.68)	12-3/8 (314.33)	1-5/8 (41.28)	26 (660.40)	25-1/8 (638.18)	49-1/8 (1247.78)	56-1/4 (1428.75)	15-1/2 (393.70)
TWE200B	71-7/8 (1825.63)	92-1/2 (2349.50)	30-1/2 (774.70)	18-7/8 (479.43)	4-1/2 (114.30)	31 (787.40)	28 (711.20)	51-7/8 (1317.63)	59-1/8 (1501.78)	18-1/8 (460.38)

Table DD-4 – (Continued)

Model No.	L	M	N	P	R	S	T	U	V	W
TWE155B	19-1/2 (495.30)	77-1/4 (1962.15)	1-1/4 (31.75)	48 (1219.20)	35 (889.00)	35 (889.00)	2-7/8 (73.03)	73-7/8 (1876.43)	3-3/4 (95.25)	3-3/8 (85.73)
TWE200B	20-7/8 (530.23)	89-1/4 (2266.95)	1-3/4 (44.45)	50-7/8 (1292.23)	39-1/8 (993.78)	39-1/8 (993.78)	4-7/8 (123.83)	82-7/8 (2105.03)	4-5/8 (117.48)	3-1/8 (79.38)

Table DD-4 – (Continued)

Model No.	Y	Z	AA	AB	AC	AD	AE	AF
TWE155B	18 (457.20)	73-7/8 (1876.43)	3-3/4 (95.25)	2-7/8 (73.03)	18 (457.20)	3-5/8 (92.08)	35 (889.00)	35 (889.00)
TWE200B	20-1/8 (511.18)	82-7/8 (2105.03)	4-5/8 (117.48)	4-7/8 (123.83)	20-1/8 (511.18)	3 (76.20)	39-1/8 (993.78)	39-1/8 (993.78)

Dimensional Data

Figure DD-14 – TWE200E Air Handler
All dimensions are in inches and millimeters.

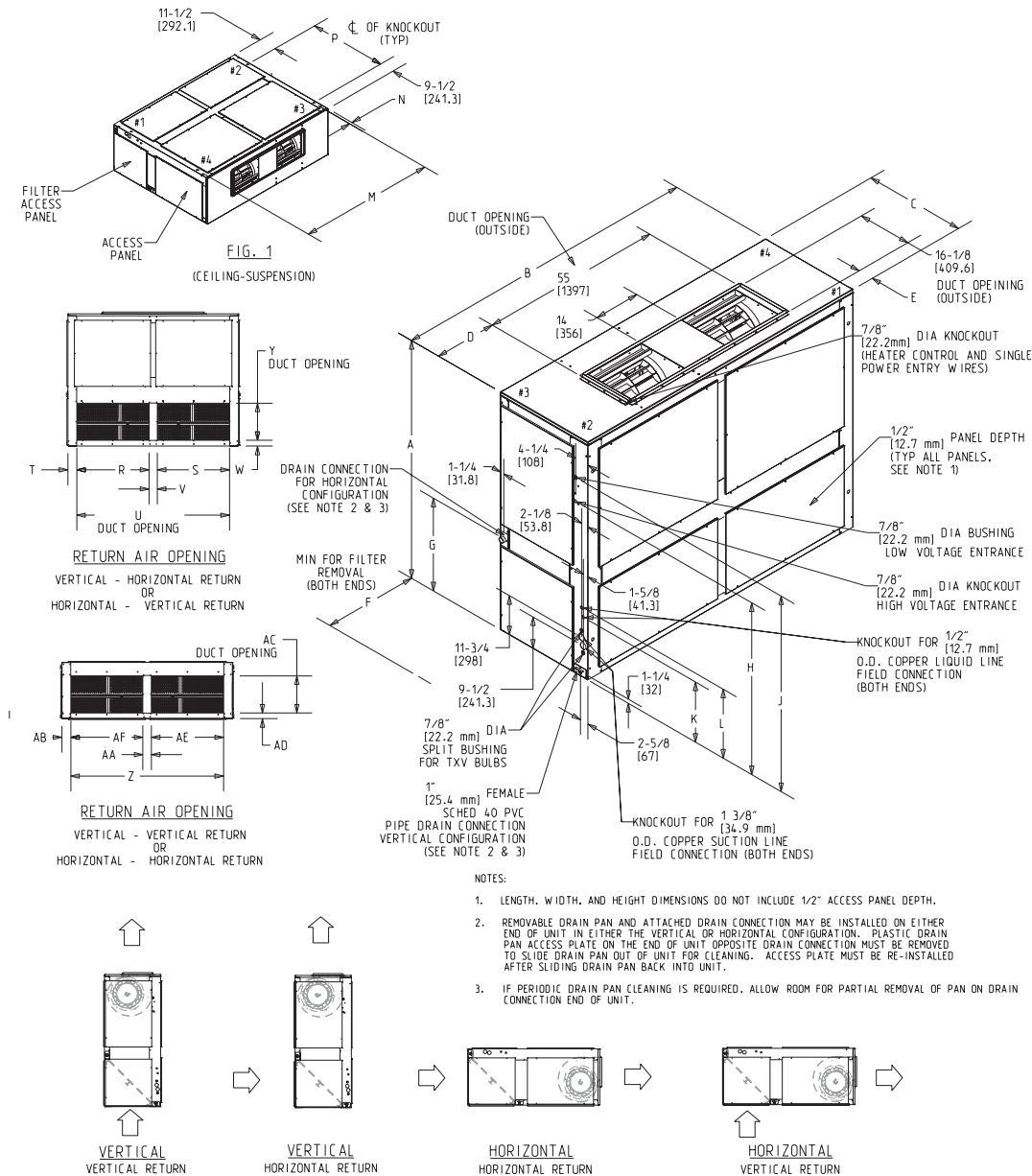

Table DD-5 – Air Handler Dimensions – in.(mm)

Model No.	A	B	C	D	E	F	G	H	J	K	L	M	N	P	R
TWE200E	71 7/8"	92 5/8"	30 1/2"	18 7/8"	4 1/2"	28 1/2"	28"	51 7/8"	59 1/8"	18 1/8"	20 7/8"	89 1/4"	1 3/4"	50 7/8"	39 1/8"
	(1826)	(2353)	(775)	(479)	(114)	(724)	(711)	(1318)	(1502)	(460)	(530)	(2267)	(45)	(1292)	(994)

Table DD-5 – (Continued)

Model No.	S	T	U	V	W	Y	Z	AA	AB	AC	AD	AE	AF
TWE200E	39 1/8"	4 7/8"	82 7/8"	4 5/8"	3 1/8"	20 1/8"	82 7/8"	4 5/8"	4 7/8"	20 1/8"	3 1/8"	39 1/8"	39 1/8"
	(994)	(124)	(2105)	(118)	(79)	(511)	(2105)	(117)	(124)	(511)	(79)	(994)	(994)

Dimensional Data

Figure DD-15— Electric Heater for TWE050, 075, 100 Air Handlers

All dimensions are in inches and millimeters.

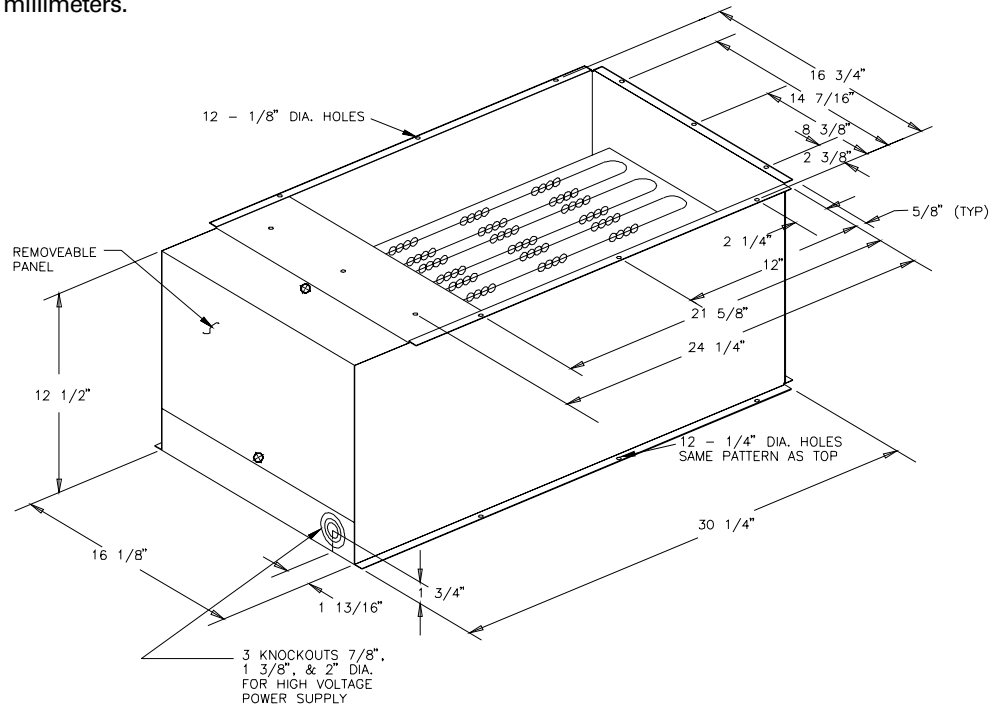
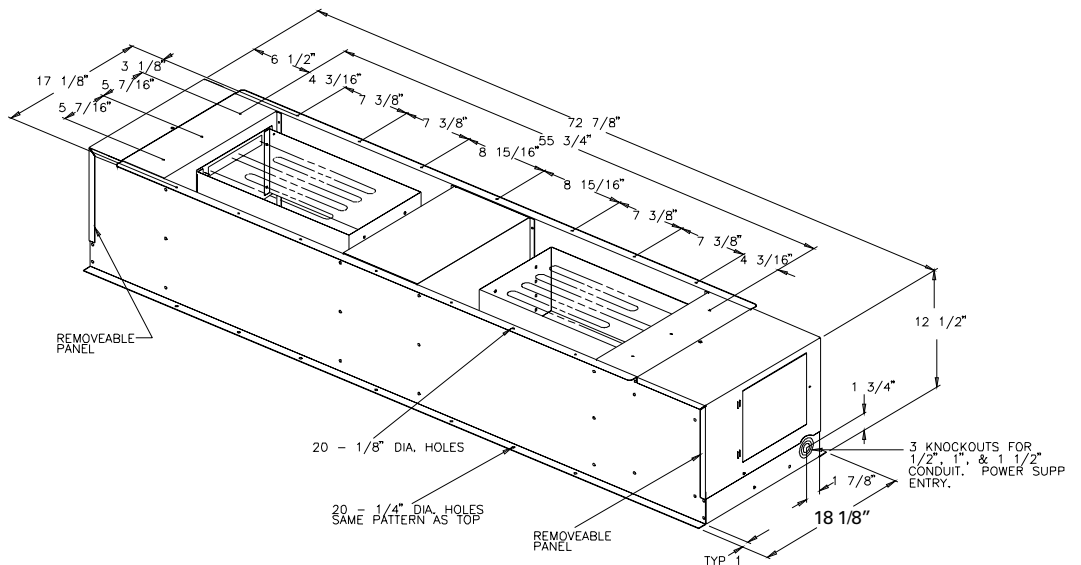

Figure DD-16 — Electric Heater for TWE155 and 200 Air Handlers



Dimensional Data

Figure DD-17 — Discharge Plenum and Grille
All dimensions are in inches and millimeters.

Table DD-6 — Discharge Plenum And Grille Dimensions — in. (mm)

Model	Model No.	A	B	C
TWE050	BAYPLNM015	37 ⁷ / ₈ (962)	21 ⁷ / ₈ (555.6)	28 (711.2)
TWE075	BAYPLNM016	47 ¹ / ₂ (1206.5)	25 (635)	28 (711.2)
TWE100	BAYPLNM017	63 ¹ / ₂ (1612.9)	25 (635)	28 (711.2)

**Table DD-7 — Discharge Plenum And Grille Dimensions — in. (mm)
For Use with Electric Heat**

Model	Model No.	A	B	C
TWE050	BAYPLNM025	37 ⁷ / ₈ (962)	21 ⁷ / ₈ (555.6)	29 (736.6)
TWE075	BAYPLNM026	47 ¹ / ₂ (1206.5)	25 (635)	29 (736.6)
TWE100	BAYPLNM027	63 ¹ / ₂ (1612.9)	25 (635)	29 (736.6)
TWE155	BAYPLNM028	79 ¹ / ₂ (2019.3)	27 ⁵ / ₈ (701.7)	35 (889)
TWE200	BAYPLNM029	92 ¹ / ₂ (2349.5)	30 ³ / ₈ (771.5)	35 (889)

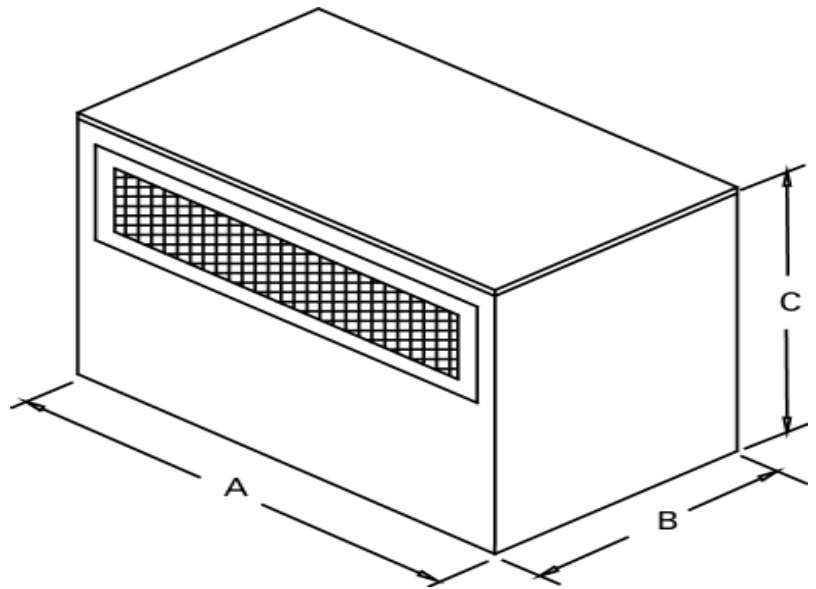
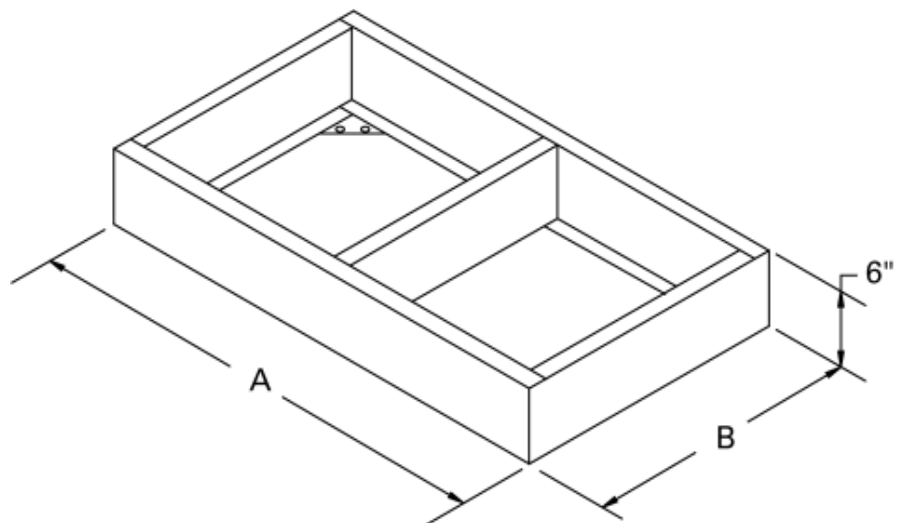

Figure DD-18 — Subbase

Table DD-8 — Subbase Dimensions — in. (mm)

Model	Model No.	A	B
TWE050	BAYBASE001	38 (965.2)	22 (558.8)
TWE075	BAYBASE002	47 ¹ / ₂ (1206.5)	25 (635)
TWE100	BAYBASE003	63 ¹ / ₂ (1612.9)	25 (635)
TWE155	BAYBASE004	79 ¹ / ₂ (2019.3)	27 ⁵ / ₈ (701.7)
TWE200	BAYBASE005	92 ¹ / ₂ (2349.5)	30 ³ / ₈ (771.5)



Weights

Table W-1 – Unit and Corner Weights – Net Lbs (kg)

Unit Model No.	Shipping Maximum (lbs)	Net Maximum (lbs)	Corner Weights			
			1	2	3	4
TTA075A	370 (167.8)	326 (147.9)	105 (47.6)	83 (37.6)	61 (27.7)	77 (34.9)
TTA085A, 100A	443 (200.9)	399 (181.0)	149 (67.6)	116 (52.6)	78 (35.4)	100 (45.4)
TTA100B	481 (218.2)	427 (193.7)	133 (60.3)	135 (61.2)	87 (39.5)	85 (38.6)
TTA100C	492 (223.2)	437 (198.2)	139 (63.1)	122 (55.3)	87 (39.5)	95 (43.1)
TTA125B	481 (218.2)	427 (193.7)	133 (60.3)	135 (61.2)	87 (39.5)	85 (38.6)
TTA155B	764 (346.6)	679 (308.0)	196 (88.9)	193 (87.5)	144 (65.3)	146 (66.2)
TTA155C	764 (346.6)	679 (308.0)	196 (88.9)	193 (87.5)	144 (65.3)	146 (66.2)
TTA200B	948 (430.0)	863 (391.5)	247 (112.0)	244 (110.7)	185 (83.9)	187 (84.8)
TTA200F	920 (418)	835 (379)	292 (133)	181 (83)	222 (101)	140 (64)

Table W-2 – Accessory Weights – Net Lbs (kg)

Unit Model No.	RIS Isolators	Steel Spring Isolators	Anti-Short Cycle Timer	Coil Guard	Thermostats	Low Ambient
TTA075A	2 (.9)	12 (5.4)	1 (.5)	8 (3.6)	1 (.5)	23 (10.4)
TTA100A						
TTA100B	2 (.9)	12 (5.4)	1 (.5)	11 (5.0)	1 (.5)	23 (10.4)
TTA100C						
TTA125B	2 (.9)	12 (5.4)	1 (.5)	20 (9.1)	1 (.5)	23 (10.4)
TTA155B	2 (.9)	12 (5.4)	1 (.5)	22 (10.0)	1 (.5)	23 (10.4)
TTA155C						
TTA200B	2 (.9)	12 (5.4)	1 (.5)	34 (15.4)	1 (.5)	23 (10.4)
TTA200F	2 (.9)	12 (5.4)	1 (.5)	45 (20.4)	1 (.5)	42 (19.1)

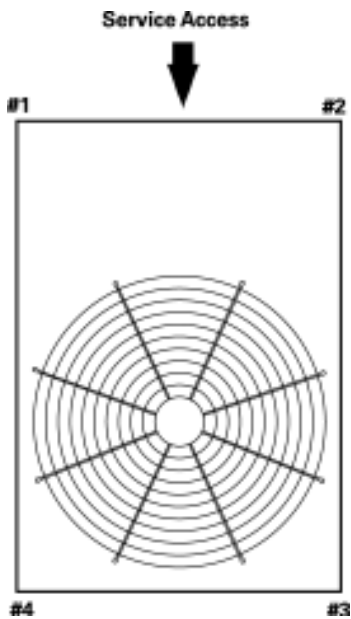

TTA075, 100, 125

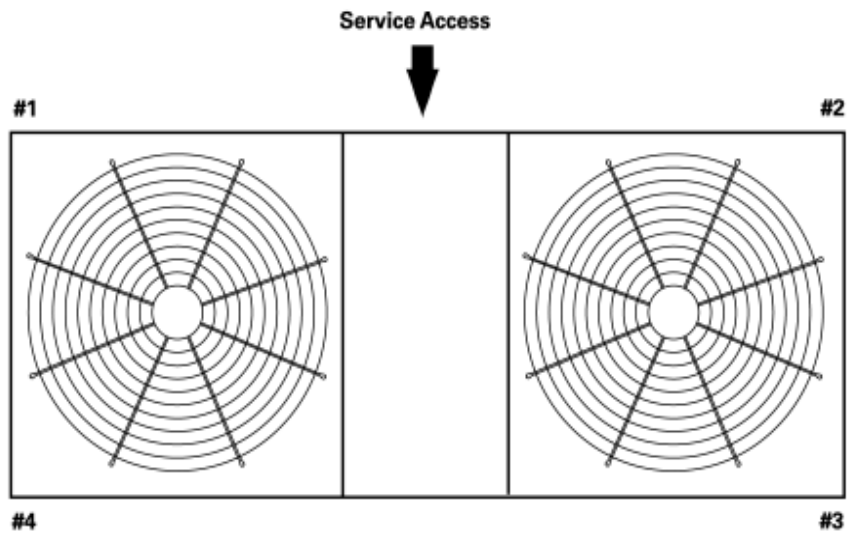

TTA155, 200

Weights

Table W-3 – Air Handlers and Corner Weights – lb' (kg)

Unit Model No.	Shipping Maximum	Net Maximum	Corner Weights – Vertical				Corner Weights – Horizontal			
			1	2	3	4	A	B	C	D
TWE050A	298 (135.2)	232 (105.2)	59 (26.8)	59 (26.8)	59 (26.8)	59 (26.8)	54 (24.5)	64 (29.0)	64 (29.0)	54 (24.5)
TWE075A	388 (176.0)	317 (143.8)	79 (35.8)	79 (35.8)	79 (35.8)	79 (35.8)	73 (33.1)	81 (36.7)	84 (38.1)	77 (34.9)
TWE100A										
TWE100B	439 (199.1)	392 (177.8)	98 (44.5)	98 (44.5)	98 (44.5)	98 (44.5)	95 (43.1)	101 (45.8)	101 (45.8)	95 (43.1)
TWE155B	754 (342.0)	692 (313.9)	173 (78.5)	173 (78.5)	173 (78.5)	173 (78.5)	156 (70.8)	174 (78.9)	190 (86.2)	170 (77.1)
TWE200B	886	816	204 (92.5)	204 (92.5)	204 (92.5)	204 (92.5)	179 (81.2)	221 (100.2)	228 (103.4)	185 (83.9)
TWE200E	857 (390)	787 (357)	109 (50)	262 (119)	154 (70)	262 (119)	192 (87)	229 (104)	130 (59)	236 (107)

NOTE:

1. If application requires steam or hot water heating coils, field supplied isolators must be utilized.

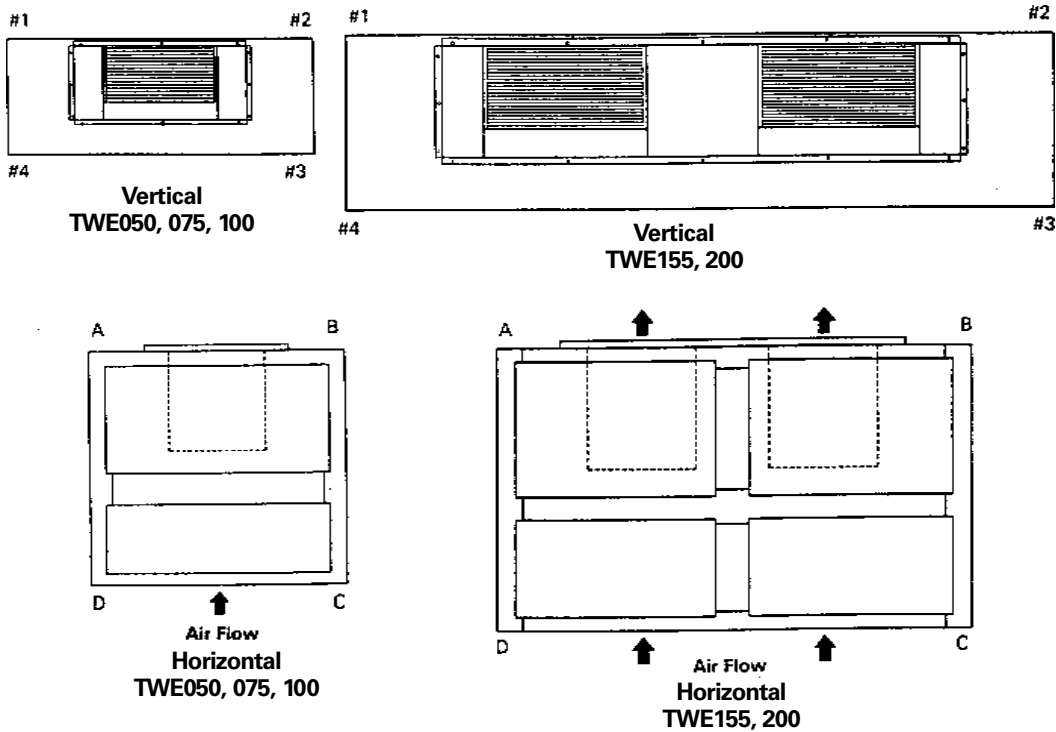

Table W-4 – Accessory Weights – Net Lbs (kg)

Unit Model No.	Discharge Plenum And Grille ¹	Discharge Plenum And Grille ²	Discharge Plenum And Grill ³	Return Air Grille	Electric Heat Min./Max.	Oversized Subbase Motor	RIS Isolator Floor Mount	RIS Isolator Suspended Mount
TWE050A	63 (28.6)	58 (26.3)	93 (42.2)	3 (1.4)	32/43 (14.5/19.5)	14 (6.4)	31 (14.1)	2 (.91)
TWE075A	78 (35.4)	73 (33.1)	123 (55.8)	5 (2.3)	27/45 (12.2/20.4)	19 (8.6)	48 (21.8)	6 (2.7)
TWE100A								
TWE100B	97 (44.0)	92 (41.7)	156 (70.8)	7 (3.2)	27/45 (12.2/20.4)	23 (10.4)	50 (22.7)	7 (3.2)
TWE155B	—	124 (56.2)	230 (104.3)	10 (4.5)	79/100 (35.8/45.4)	27 (12.2)	80 (36.3)	7 (3.2)
TWE200B, E	—	145 (65.8)	264 (119.8)	12 (5.4)	79/100 (35.8/45.4)	31 (14.1)	88 (39.9)	9 (4.1)

NOTES:

1. For use when no heat is supplied.
 2. For use with electric heat.



Mechanical Specifications

Condensing Units

General

Units shall be assembled on heavy gauge steel mounting/lifting rails and shall be weather proofed. Units shall include hermetic scroll compressors, plate fin condenser coils, fans and motors, controls and holding charge of nitrogen. Operating range shall be between 115°F and 50°F in cooling as standard from the factory. Units shall be UL 1995 listed, certified and rated in accordance with ARI Standard 340/360 or 365.

Casing

Unit casing shall be constructed of 18 gauge zinc coated heavy gauge, galvanized steel. Exterior surfaces shall be cleaned, phosphatized and finished with a weather-resistant baked enamel finish. Units surface shall be tested 500 hours in salt spray test. Units shall have removable end panels which allow access to all major components and controls.

Refrigeration System – Single Compressor

TTA075A, TTA100A units shall have a single refrigeration circuit. Each refrigeration circuit has an integral subcooling circuit. A refrigeration filter drier shall be provided as standard. The TTA075A, TTA100A units shall have both a liquid line and suction gas line service valve with gauge port.

TTA075A, TTA100A units shall have one direct-drive hermetic scroll compressor with centrifugal oil pump providing positive lubrication to moving parts. Motor shall be suction gas-cooled and shall have a voltage utilization range of plus or minus 10 percent of unit nameplate voltage. Crankcase heater, internal temperature and current-sensitive motor overloads shall be included for maximum protection. Scroll type compressor shall provide inherently low vibration and noise by having no suction and discharge valves. External high and low pressure cutout devices shall be provided. Evaporator defrost control provided in indoor blower coil shall prevent compressor slugging by temporarily interrupting compressor operation when low evaporator coil temperatures are encountered.

Refrigeration System – Dual Compressor

TTA100B, TTA125B, TTA155B, TTA200B units shall have two separate and independent refrigeration circuits. Each refrigeration circuit shall have an integral subcooling circuit. A refrigeration filter drier shall be provided as standard. Units shall have both a liquid line and suction gas line service valve with gauge port.

TTA100B, TTA125B, TTA155B, and TTA200B units shall have two Trane direct-drive hermetic scroll compressors with centrifugal oil pump and provide positive lubrication to all moving parts. Motor shall be suction gas-cooled and shall have a voltage utilization range of plus or minus 10 percent of nameplate voltage. Crankcase heater, internal temperature and current-sensitive motor overloads shall be included for maximum protection. Scroll compressor shall provide inherently low vibration and noise by having no suction and discharge valves. External high and low pressure cutout devices shall be provided. Evaporator defrost control provided in indoor blower coil shall prevent compressor slugging by temporarily interrupting compressor operation when low evaporator coil temperatures are encountered.

Refrigeration System – Dual Manifolder Compressors

TTA 100C, TTA155C and TTA200F units shall have a single refrigeration circuit with an integral subcooling circuit. A refrigeration filter drier shall be provided as standard. Units shall have both a liquid line and suction gas line service valve with gauge port.

The units shall have two scroll compressors manifolded together. Motor shall be suction gas-cooled and shall have a voltage utilization range of plus or minus 10 percent of nameplate voltage. Crankcase heater, internal temperature and current-sensitive motor overloads shall be included for maximum protection. Scroll type compressor shall provide inherently low vibration and noise by having no suction and discharge valves. External high and low pressure cutout devices shall be

provided. Evaporator defrost control provided in the indoor blower coil shall prevent compressor slugging by temporarily interrupting compressor operation when low evaporator coil temperatures are encountered.

Condenser Coil

Coils shall be internally finned 3/8" copper tubes mechanically bonded to configured aluminum plate fin as standard. Factory pressure and leak tested to 660 psig. Metal grilles with PVC coating for coil protection are optional.

Condenser Fan And Motor(s)

Direct-drive, statically and dynamically balanced 26 or 28 inch propeller fan(s) shall be used in draw-through vertical discharge position. Either permanently lubricated totally enclosed or open construction motors shall be provided and shall have built in current and thermal overload protection. Motor(s) shall be either ball or sleeve bearing type.

Mechanical Specifications

Condensing Units

Controls

Condensing units shall be completely factory wired with necessary controls and contactor pressure lugs or terminal block for power wiring. Unit shall provide an external location for mounting a fused disconnect device.

A choice of microprocessor or electro-mechanical controls shall be available. The 24-volt electro-mechanical control circuit shall include control transformer and contactor pressure lugs for power wiring. Units shall have single point power entry as standard. The microprocessor controls shall provide for all 24-volt control functions. The resident control algorithms shall make all heating, cooling and/or ventilating decisions in response to electronic signals from sensors measuring indoor and outdoor temperatures. The control algorithm maintains accurate temperature control, minimizes drift from set point, and provides better building comfort. A centralized microprocessor shall provide anti-short cycle timing and time delay between compressors to provide a higher level of machine protection.

Time delay timers shall be provided to help prevent compressors in dual compressor units from simultaneous start-up. An anti-short cycle timer shall be available as an optional accessory.

Zone Sensor

This field installed control shall be provided to interface with the Micro equipped units and shall be available in either manual, automatic programmable with night setback, with system malfunction lights, or remote sensor options.

Thermostat

Two stage heating and cooling operation or one stage heating and cooling shall be available for field installation in either manual or automatic changeover. Automatic programmable electronic with night setback shall also be available.

LonTalk® Communication Interface

This factory or field installed option shall be provided to allow the unit to communicate as a Tracer™ LCI-R device or directly with generic LonTalk Network Building Automation System Controls.

Low Ambient Operation

Standard units shall start and operate to approximately 50°F when matched with air handlers and coils. Optional head pressure control accessory permits operation to 0°F.

FACTORY INSTALLED ACCESSORIES

Black Epoxy Coated Condenser Coil —

This option is designed to provide corrosion protection of air cooled condenser coils for seacoast application. The black epoxy coil protection is a factory applied thermoset vinyl coating, bonded to normal aluminum fin stock. The uniform thickness of the bonded vinyl layer exhibits excellent corrosion protection in salt spray tests performed in accordance with ASTM B177.

ACCESSORIES

Low Ambient Head Pressure Control —

Shall control fan motor in response to outdoor ambient temperature and liquid line temperature. Accessory provides unit cooling operation to outdoor temperatures of 0F.

Vibration Isolation Packages — Shall reduce transmission of noise and vibration to building structures, equipment and adjacent spaces. Packages shall be available in either neoprene-in-shear or spring-flex types.

Hot Gas Bypass Kit — Shall be available to provide capacity modulation.

Time Delay Relay — Shall prevent compressors in dual compressor unit from coming on line simultaneously. Timer shall be 24-volt, cycle, with four minute timing period.

Anti-Short-Cycle Timer — Shall prevent rapid on-off compressor cycling in light load conditions by not allowing compressor to operate for 5-7 minutes upon shutdown. Shall consist of a solid state timing device, 24-volt, cycle with either 5 or 7 minute fixed-off timing period.

Condenser Coil Guard — Metal grille with PVC coating shall be provided to alleviate coil damage.



Mechanical Specifications

Air Handlers

General

Air handler units shall be completely factory assembled including coil, condensate drain pan, fan motor(s), filters, and controls in an insulated casing that can be applied in either vertical or horizontal configuration. Units shall be rated and tested in accordance with ARI standard 210/240, 340/360.

Casing

Unit casing shall be constructed of zinc coated, heavy gauge, galvanized steel. Exterior surfaces shall be cleaned, phosphatized, and finished with a weather-resistant baked enamel finish. Casing shall be completely insulated with cleanable, foil faced, fire-retardant, permanent, odorless glass fiber material. All insulation edges shall be either captured or sealed. Knockouts shall be provided for unit electrical power and refrigerant piping connections. Captive screws shall be standard on all access panels.

Refrigeration System

The TWE050A, TWE075A, TWE100A units shall have a single refrigeration circuit and the TWE050B, TWE075B, TWE100B, TWE155B, TWE200B units shall have dual refrigeration circuits. Each refrigeration circuit is controlled by a factory installed thermal expansion valve.

Evaporator Coil

Configured aluminum fin surface shall be mechanically bonded to $\frac{3}{8}$ " (10 mm) internally enhanced copper tubing and factory pressure and leak tested at 450 psig (3103 kPa). Coil is arranged for draw-thru airflow and shall provide a double sloped condensate drain pan constructed of PVC plastic. The drain pan shall be removable for cleaning. The condensate drain pan can be installed in any of four positions allowing for vertical or horizontal application and providing external connections on either side of the unit.

Evaporator Fan

Double inlet, double width, forward curved, centrifugal-type fan(s) with adjustable belt drive shall be standard. Thermal overload protection shall be standard on motor. Fan and motor bearings shall be permanently lubricated. Oversized motors shall be available as an option for high static application.

Controls

Magnetic evaporator fan contactor, low voltage terminal strip, check valve(s), and single point power entry shall be included. All necessary controls shall be factory-installed and wired. Evaporator defrost control shall be included to prevent compressor slugging by temporarily interrupting compressor operation when low evaporator coil temperatures are encountered.

Filters

One inch, throwaway filters shall be standard on TWE050A, TWE075A, TWE100A and TWE100B model air handlers. Filters shall be accessible from the side coil access panel. Filter rack can be field converted to two-inch capability. Two-inch throwaway filters shall be standard on TWE155B, TWE200B and TWE200E models.

Accessories

Electric Heaters — Approved electric heat modules shall be available for installation directly on fan discharge. Electric heaters shall be available in a wide range of capacities with one or two-stage control, single-point electric power connection and terminal strip connections. Electric heater elements shall be constructed on heavy-duty nickel chromium elements internally wye connected on 480/600 volt, three phase and delta connected on 208/240 volt, three phase. Each 208/240 volt,

three phase heater shall have pilot duty with secondary backup fuse links for automatic reset of high limit controls. Each 480/600 volt heater shall have automatic line break high limit controls.

Discharge Plenums and Grilles

Accessory discharge plenums shall be available for vertical, free discharge applications. Plenums shall be constructed of heavy-gauge, zinc coated, galvanized steel finished with baked enamel to match the air handler unit. Grilles shall be satin finished aluminum and have four-way adjustable louvers.

Return Air Grilles — Accessory return air grille shall be provided for vertical front, free return applications. Grilles shall be installed in place of the front lower side panel. Grille shall be satin finished aluminum with non-adjustable louvers.

Mounting Subbase — This accessory shall be available for vertical floor mount configurations. Subbase shall be constructed of heavy gauge, zinc coated, galvanized steel with baked enamel finish to match air handler unit. Subbase is required in the vertical air flow application for condensate drain trapping and when isolators are required.

Vibration Isolators — This accessory shall reduce transmission of noise and vibration to building structures, equipment, and adjacent spaces. Packages shall be available in either neoprene-in shear or spring-flex types in floor or suspended mountings.

Oversized Motors — Field installed oversized motors shall be available for high static pressure applications.

Control Options

Standard Indoor Thermostats — Two stage heating and cooling operation or one stage heating and cooling thermostats shall be available in either manual or automatic changeover.

Programmable Electronic Night Setback Thermostat — The option shall provide heating setback and cooling setup with 7-day programming capability.



TRANE®

Trane
A business of American Standard
Companies
www.trane.com

*For more information contact your
local district office, or e-mail us at
comfort@trane.com*



Literature Order Number	SS-PRC003-EN
File No.	PL-UN-SS-PRC003-EN-0606
Supersedes	PL-UN-SS-PRC003-EN-0104
Stocking Location	Electronic Only

Trane has a policy of continuous product and product data improvement and reserves the right to change design and specifications without notice.